

# RACCORDO SERIE RG

# ELBOW COUPLING RG

Material: **Acciaio** ASTM A105

Material: **Steel** ASTM A105

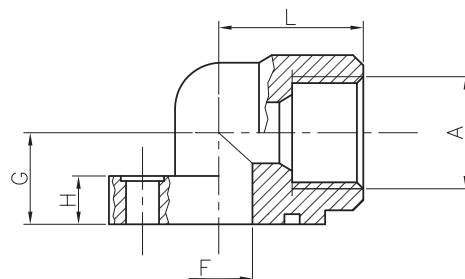
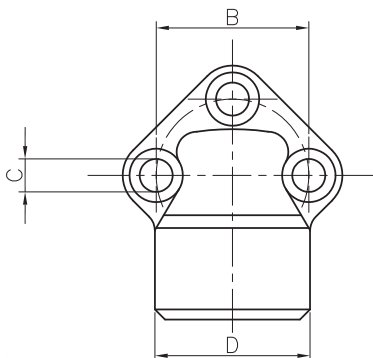

TIPO	PRESS. MAX ES [Bar]	GRUPPO POMPA	DIMENSIONI - DIMENSIONS								N° FORI	VITI METRICHE	O-RING
TYPE	MAX PRESS. [Bar]	PUMP GROUP	A	B	C	D	F	G	H	L	HOLES	METRIC SCREWS	
RG 26 3/8"	300	0,5	3/8" gas	26	5,5	30,5	11,5	18	9,5	27	3	M5 x 20	2056
RG 26 1/2"			1/2" gas	26	5,5	30,5	11,5	18	9,5	27			
RG 26 M18x1,5			M18x1,5	26	5,5	30,5	11,5	18	9,5	27			
RG 30 3/8"	300	1	3/8" gas	30	6,5	30,5	11,5	18	9,5	27	3	M6 x 20	121
RG 30 1/2"			1/2" gas	30	6,5	30,5	11,5	18	9,5	27			
RG 30 M18x1,5			M18x1,5	30	6,5	30,5	11,5	18	9,5	27			
RG 40 3/8"	300	2	3/8" gas	40	8,5	40	20	21	10,5	38	3	M8 x 25	132
RG 40 1/2"			1/2" gas	40	8,5	40	20	21	10,5	38			
RG 40 3/4"			3/4" gas	40	8,5	40	20	21	10,5	38			
RG 40/23,5 1/2"			1/2" gas	40	8,5	40	23,5	21	10,5	38			
RG 40/23,5 3/4"			3/4" gas	40	8,5	40	23,5	21	10,5	38			2100
RG 51 3/4"	300	3A	3/4" gas	51	10,5	45	25	27	13,5	47	3	M10 x 30	3125
RG 51 1"			1" gas	51	10,5	45	25	27	13,5	47			
RG 56 3/4"		3B	3/4" gas	56	10,5	45	34	27	13,5	47			3150
RG 56 1"			1" gas	56	10,5	45	34	27	13,5	47			
RG 62 1"	300	3,5	1" gas	62	10,5	60	32	36	19	56	3	M10 x 35	4150
RG 62 1" 1/4			1" 1/4 gas	62	10,5	60	32	36	19	56			
RG 62 1" M12			1"	62	12,5	60	32	36	19	56			
RG 62 1" 1/4 M12			1" 1/4 gas	62	12,5	60	32	36	19	56			
RG 72,5 1" 1/4	300	4	1" gas	72,5	12,5	62	38	38	16	58	3	M12 x 35	4187
RG 72,5 1" 1/2			1" 1/2 gas	72,5	12,5	62	38	38	16	58			
RG 92 2" 1/2 *	10	5	2" 1/2 gas	92	12,5	95	63	50	21	75	3	M12 x 40	173

\* Materiale: Ghisa | Material: Cast Iron

A richiesta si eseguono anche a saldare di tasca | On request we also produce it socket welding

<p>ESEMPIO DI ORDINAZIONE ORDERING EXAMPLE</p>	RG 30 1/2"	SOLO RACCORDO / ONLY JOINT
	RG 30 1/2" C	RACCORDO COMPLETO CON VITI METRICHE, RONDELLE E O-RING JOINT COMPLETE WITH METRIC SCREWS, WASHERS AND O-RING