

SVCP

VALVOLA NORMALMENTE APERTA, PILOTATA
NORMALLY OPEN, PILOTTED POPPET TYPE

CARATTERISTICHE TECNICHE TECHNICAL CHARACTERISTICS

Pressione massima Maximum pressure	300 bar (4350 psi)
Portata nominale Nominal Flow	40 l/min (10,6 gpm)
Temperatura di esercizio Operating temperature	-30 / 100 °C
Cavità Cavity	C007
Trafilamento interno Internal leakage	5 cc/min (50 °C; 21 cSt; 300 bar)
Coppia Torque	45-50 Nm
Peso Weight	0,11 kg

SCHEMA IDRAULICO HYDRAULIC SCHEME

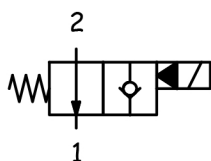

BOBINA COIL

13-39
18 W

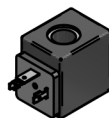

pag. CV.CL.001.13

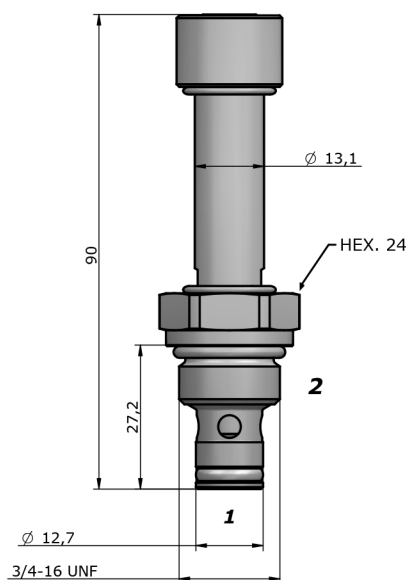

PRESTAZIONI PERFORMANCES

2 --> 1

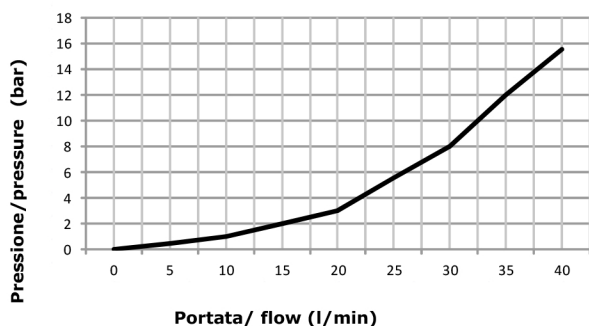

DESCRIZIONE DESCRIPTION

Quando la bobina è eccitata, la valvola blocca il passaggio da 2 a 1.

Quando la bobina è diseccitata, la SVCP consente il flusso libero da 2 a 1, mentre lo blocca da 1 a 2.

When the coil is energized, blocking flow from 2 to 1.

When the coil is de-energized, the SVCP allows flow from 2 to 1, while flow from 1 to 2 is severely restricted.

CODICE D'ORDINAZIONE ORDERING CODE

SVCP-S08-TS2-N-0-D12-D-S200

GUARNIZIONI / SEAL

N = NBR
V = VITON

REGOLAZIONE / REGULATION

0 = SENZA COMANDO MANUALE / NO MANUAL OVERRIDE
3 = PRESSIONE SU SPINA / PUSH PIN
4 = PRESSIONE SU BOTTONE / PUSH BOTTON
5 = BRUGOLA / ALLEN

TENSIONE / VOLTAGE

000 = SENZA BOBINA / WITHOUT COIL
D12 = 12 VDC
D24 = 24 VDC
220 = 220 RAC

TIPO CONNETTORE / CONNECTOR TYPE

0 = SENZA BOBINA / WITHOUT COIL
C = CAVI / LEADS
D = DIN 43650
G = DEUTSCH DT04-2P
A = AMP JUNIOR

DIMENSIONE CORPO / SIZE BODY

OMETTERE/OMIT
100
200
101
201
102
202

MATERIALE CORPO / MATERIAL BODY

OMETTERE/OMIT
S = STEEL
A = ALLUMINIUM

SVCP

VALVOLA NORMALMENTE APERTA, PILOTATA
NORMALLY OPEN, PILOTED POPPET TYPE

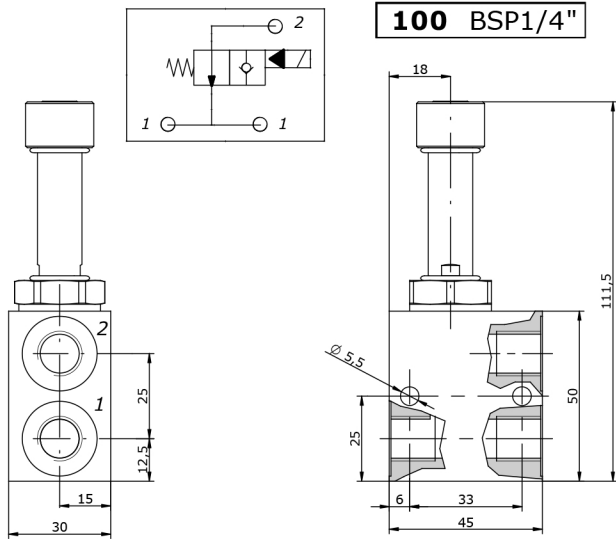

100 BSP1/4"

Peso / weight A : 0,25 kg
Peso / weight S : 0,52 kg

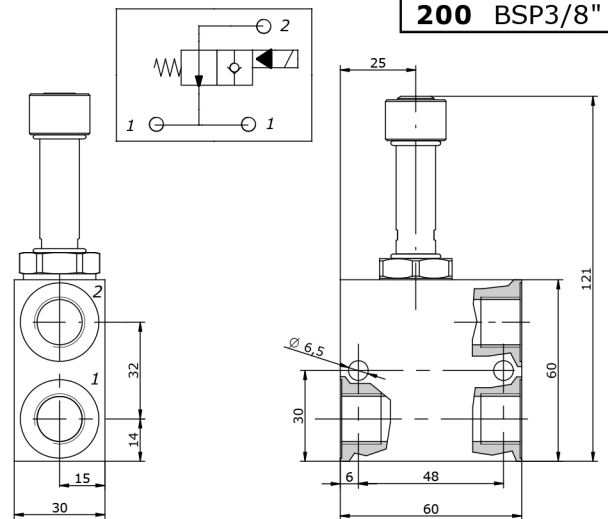

200 BSP3/8"

Peso / weight A : 0,34 kg
Peso / weight S : 0,76 kg

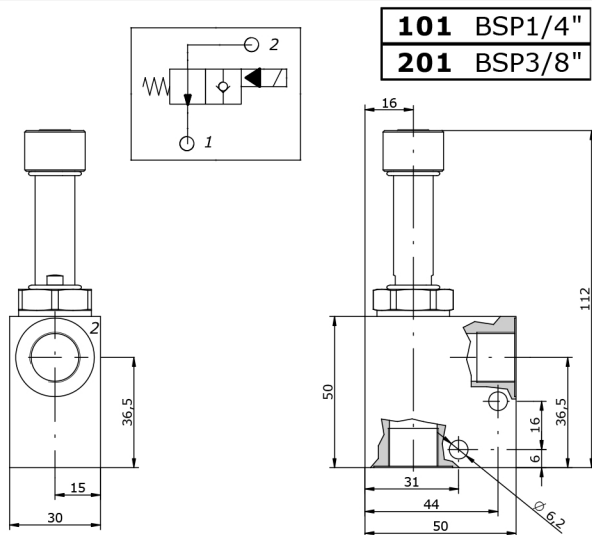

101 BSP1/4"
201 BSP3/8"

Peso / weight A : 0,27 kg
Peso / weight S : 0,57 kg

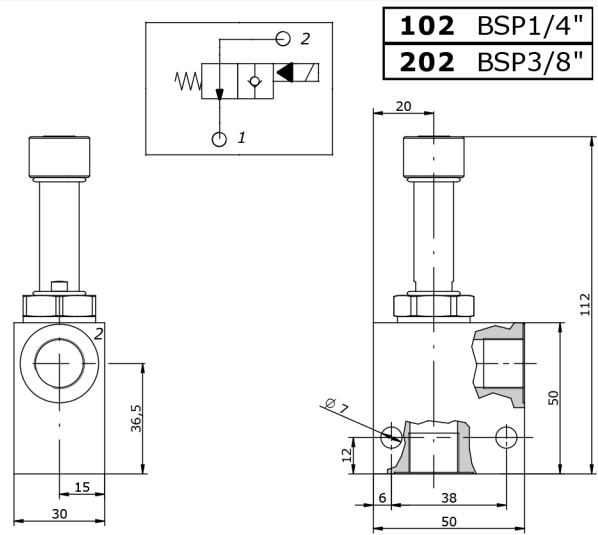

102 BSP1/4"
202 BSP3/8"

Peso / weight A : 0,26 kg
Peso / weight S : 0,56 kg

A RICHIESTA ON REQUEST

Trattamenti superficiali per corpi valvola / Manifold surface treatments

- **ALLUMINIO**: Ossidazione anodica colorata (nero, blu, oro, rosso);
ACCIAIO: Fosfatazione; brunitura

- **ALUMINIUM**: Colored anodizing (black, blue, gold, red);
STEEL: Phosphating; bluing.

NOTE
NOTES
