

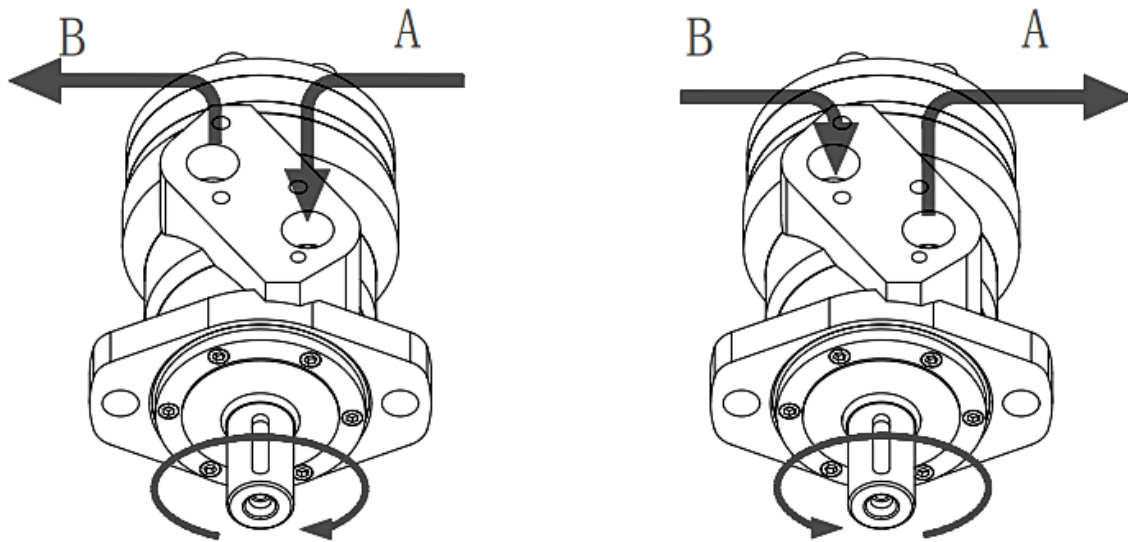

Standard information

1. Output steering (as shown in the picture, oil porta A and B are inlet and outlet)



2. Whether the use of the motor is correct will directly affect the working life, therefore, the following basic requirements must be met

2.1: System Requirement -

1. The system should be equipped with the corresponding oil filter to ensure the cleanliness of the system oil.
2. The hydraulic circuit must be equipped with a cooling system to prevent excessive oil temperature.
3. Pressure gauges and thermometers should be installed.
4. A pressure gauge should be installed in the oil circuit of the hydraulic pump.

2.2 System hydraulic fluid requirements -

$$(25-70) \times 10^{-6} \text{m}^2 / \text{s}$$

According to the different ambient temperature and use, the oil used should have good viscosity temperature performance, good defoaming, anti-oxidation, anti-rust, and high flash point. During the operation of the motor, its viscosity is between $(25-70) \times 10^{-6} \text{m}^2 / \text{s}$, and the water, alkali and mechanical impurities in the oil shall not exceed the allowable value.

Anti-wear hydraulic oil is recommended if the filtration accuracy of the system is better than $20\mu\text{m}$ and the normal working oil temperature is $20-60^\circ\text{C}$, and the short-term working temperature is not higher than 70°C .



Motor Mounting

1. This type of motor can not operate under pump conditions, let alone be used as a pump.
2. Any oil in the motor if stored for an extended period of time should be drained.
3. The motor mounting should be sufficient to avoid vibration during rotation.
4. The installation shall ensure that the dimensions of the connecting flange, stop and output connecting shaft are accurate.
5. Ensure that the output shaft and the connected transmission device have a good concentricity, the output shaft should be installed to prevent the output shaft and the connecting device from axial top dead phenomenon. (The motor is subject to less radial force.)
6. During the installation process, protect the smoothness and parallelism of the connecting plate of the oil inlet and outlet to prevent damage caused by poor oil sealing effect and oil leakage.
7. The motor cannot be installed forcibly or twisted.
8. Mounting bolts must be tightened evenly.
9. When the motor is running unsmoothly at low speed, it can be eliminated by applying back pressure, and the back pressure value is not less than 0.2Mpa.



12. When the system is connected, the installation position of the oil inlet and outlet of the motor on the installation drawing should be checked with the rotation relationship of the motor. During installation, it is found that the inlet and outlet of the oil port is not suitable for the positive and negative rotation direction of the corresponding output shaft, and the installation of the inlet and outlet tubing on the A and B cavities can achieve the opposite effect of the original working rotation direction.

13. The motor has two built-in check valves, and the leaking oil can be returned to the return pipe through the check valve (attached figure)

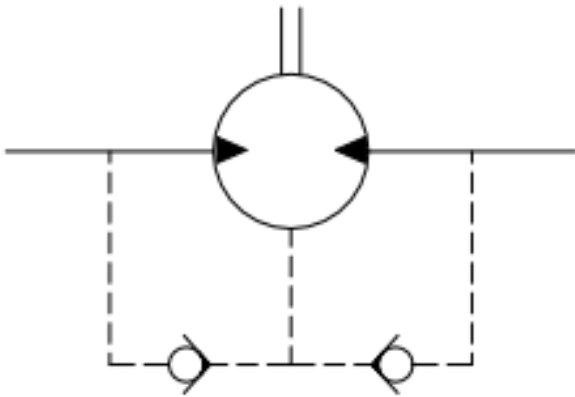

14. Drainage pipe connection method

- A) When the oil return pressure is less than 1Mpa, there is no need to connect the drainpipe
- B) When the oil return pressure is greater than 1Mpa, the drain pipe must be connected. (Drainage pipe location diagram)

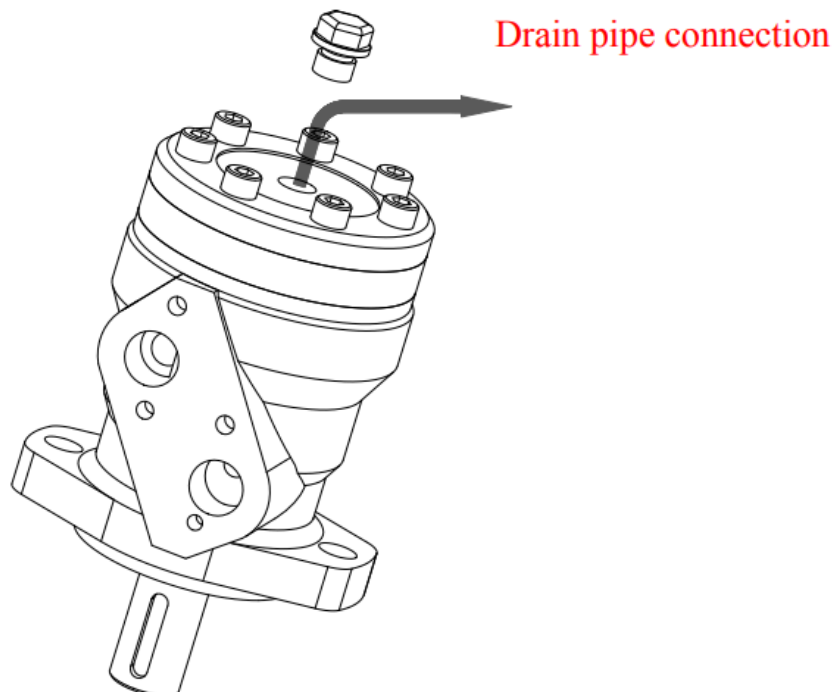



Motor Use

The pressure, flow and output power of the motor cannot exceed the specified value. When running for a long time, the oil temperature does not exceed 60°C. Motor limit operating temperature: -40°C -90 °C.

1. Before starting, check whether the motor installation and connection are correct and firm, and whether the system is correct.
2. Check whether the direction of oil inlet and outlet and the direction of motor rotation meet the requirements of working conditions. The pressure of the relief valve of the oil supply line is adjusted to the lowest value, and gradually adjusted to the required pressure after operation. Tighten the inlet and outlet pipe and drain pipe.
3. After the motor runs under no-load for at least 10 minutes, it is gradually pressurized to the working pressure, and it is observed whether the motor runs normally at any time during operation.
4. During operation, the working condition of the motor and system should be checked frequently. If abnormal temperature rise, leakage, vibration and noise or abnormal pressure pulsation are found, the machine should be shut down immediately and the cause should be identified.



In the process of use, when the oil inlet temperature is ≥ 65 °C, please check whether the cooler is working normally to ensure the normal working temperature of the motor surface.

Packaging, Transportation and Storage

Motor transportation should be equipped with appropriate wooden boxes and cardboard boxes according to the size of the motor, and plastic paper packaging on the surface of the motor to prevent water, moisture and moisture from invading the motor, causing motor rust and motor failure.



Avoid placing the motor directly on the ground. Do not need to be coated with anti-rust oil for a long time. Motor storage environment: 10-90%RH, -20-65°C.

The motor should avoid moisture, moisture and any corrosive gases as much as possible during transportation and storage

Motor Troubleshooting

The motor is a precision component that needs to be installed and repaired by professionals. Without the consent of the company, it shall not be dismantled, inspected and repaired by itself. If permitted by the company and the user has the conditions for dismantling, after reading the instructions in detail, you can dismantle yourself, but you must pay attention to the following three points:

- Be careful not to scratch the parts during decomposition, especially to protect the moving surface and sealing surface of the parts. The decomposed parts are placed in a clean container to avoid colliding with each other. Do not strike with a hammer when disassembling or assembling.
- The removed parts should be carefully inspected, and the worn parts are basically not repaired by themselves but replaced. In principle, all seals should be replaced.
- Clean and dry all parts before assembly. Do not use cotton yarn or rags to wipe any parts. The assembly site and the tools used should be clean, and the output shaft should be rotated after assembly and should be flexible without stuck phenomenon.



Common problems

1. **Motor isn't running .**

- Hydraulic Pump is not started, if it isn't, re-start the pump.
- The Tank is low in fuel, if this is the case refuel.
- The reversing valve is in the middle position, if it is please adjust it to open.
- System Relief Valve fully open this can be resolved by the system pressure if adjusted to the specific value.

2. **Motor has a strange noise**

- Insufficient motor torque, if this is the case change the motor.
- There might be air in the hydraulic system, find the reason for the intake to remove air from the oil.
- Motor might be failing which you will need to replace.

3. **Motor leakage**

- Support bearing might be broken, change the bearing.
- Seal Failure, replace the seal.
- Parts have pores, sand holes cracks etc, replace the wearing parts.

4. **Motor heating**

- Hydraulic oil temperature is too high which you will need to increase cooling capacity.
- Motor inefficiency, in this case you need to change to a different motor.

5. **Leakage from the leak hole is increasing**

- Abnormal wear on the distribution shaft which will need replacing.
- Cycloidal wheel stator body pin group wear which will need replacing.

Maintenance and Post Processing

Regularly check the hydraulic system accessories, pressure gauge accuracy, thermometer, etc.

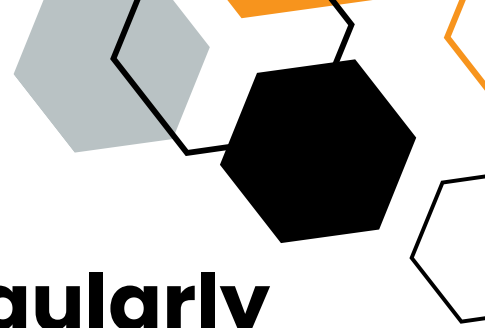

Check the hydraulic oil regularly

Mixing of different types of hydraulic oil is not allowed, and the cycle of updating new oil varies according to different industries and mines. Under normal circumstances: hydraulic oil six months a change.

Disposal of waste oil after motor use

It should be sent to a special waste oil treatment unit for centralized.

Motor is not used for a long time

The cavity should be filled with oil, and seal the oil port, the output shaft surface diagram of the grease, wrapped with cloth or sleeve.

WARNING: For user failure to comply with the above recommendations or errors

The manufacturer is not responsible for the consequences caused by the use of the motor.