

### PTHK 92 - G 2" THA

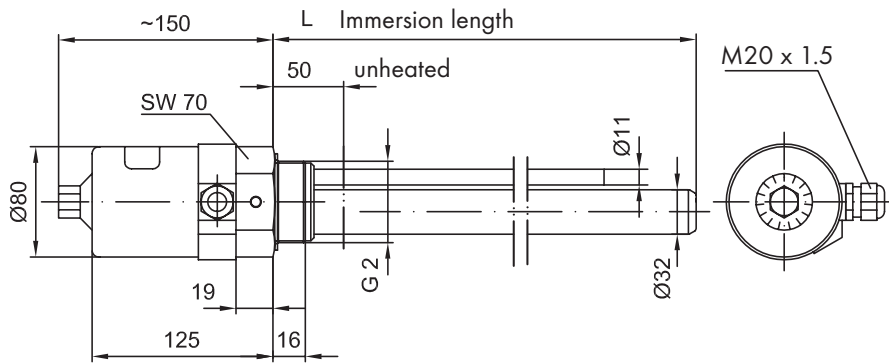

Art. No.	Power [W]	L= Immersion depth [mm]
<b>1800*</b>	450	300
<b>1802*</b>	600	400
<b>1804*</b>	750	500
<b>1806*</b>	900	600
<b>1808*</b>	1050	700
<b>1810</b>	1200	800
<b>1812</b>	1350	900
<b>1814</b>	1500	1000
<b>1816</b>	1580	1100
<b>1818</b>	1730	1200
<b>1820</b>	1880	1300
<b>1822</b>	2030	1400
<b>1824</b>	2180	1500
<b>1826</b>	2330	1600

### PTHK 92 - G 2" THI

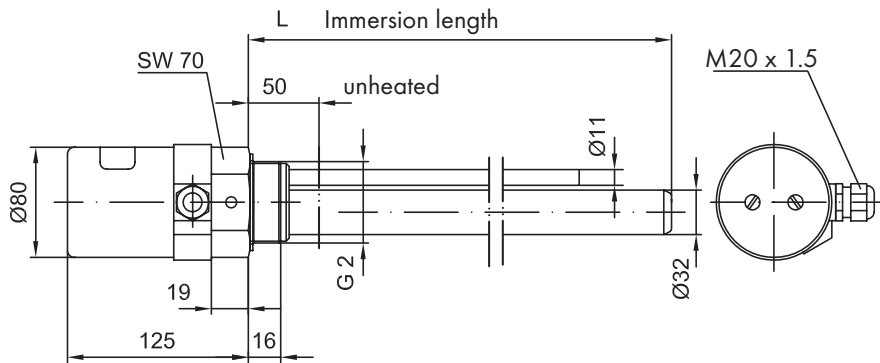

Art. No.	Power [W]	L= Immersion depth [mm]
<b>1801*</b>	450	300
<b>1803*</b>	600	400
<b>1805*</b>	750	500
<b>1807*</b>	900	600
<b>1809*</b>	1050	700
<b>1811*</b>	1200	800
<b>1813</b>	1350	900
<b>1815</b>	1500	1000
<b>1817</b>	1580	1100
<b>1819</b>	1730	1200
<b>1821</b>	1880	1300
<b>1823</b>	2030	1400
<b>1825</b>	2180	1500
<b>1827</b>	2330	1600

\*Voltage two-phase max.