

SCREWED-IN HEATERS

PRODUCT DESCRIPTION

- Heater for pre-heating of hydraulic oil on mineral oil base
- For horizontal mounting under oil level
- Surface charge approx. 1.5 W/cm² for hydraulic oils
- Bright galvanised steel cap
- Material: steel (further materials on request)
- Wiring schemes for various supply voltages on request

SERIES PTHK 90

- Exchangeable ceramic heating insert (mounting / dismounting possible without oil drain)
- Protection class IP 65



Series PTHK 90

SERIES PTHK 92

- Exchangeable ceramic heating insert (mounting / dismounting possible without oil drain)
- Temperature control for internal (THI) or external (THA) regulation, single pole 0 - 85°C, 16 ampere
- Protection class IP 54 for THA resp. IP 65 for THI



Series PTHK 92

SERIES RHK - G1 1/2"

- Protection class IP 65



Series RHK - G 1 1/2"

SERIES RHK - G1 1/2" THA / THI

- Temperature control for internal (THI) or external (THA) regulation, single pole 0 - 85°C, 16 ampere
- Protection class IP 54 for THA resp. IP 65 for THI



Series RHK - G 1 1/2" THA / THI

PTHK 92 - G 2" THA

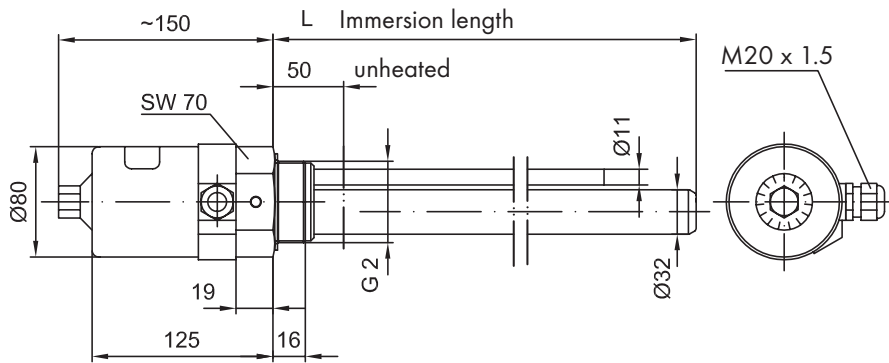

Art. No.	Power [W]	L= Immersion depth [mm]
1800*	450	300
1802*	600	400
1804*	750	500
1806*	900	600
1808*	1050	700
1810	1200	800
1812	1350	900
1814	1500	1000
1816	1580	1100
1818	1730	1200
1820	1880	1300
1822	2030	1400
1824	2180	1500
1826	2330	1600

PTHK 92 - G 2" THI

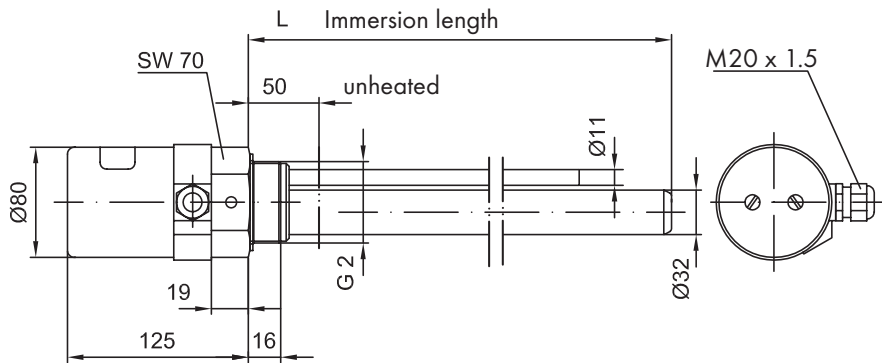

Art. No.	Power [W]	L= Immersion depth [mm]
1801	450	300
1803	600	400
1805	750	500
1807	900	600
1809	1050	700
1811	1200	800
1813	1350	900
1815	1500	1000
1817	1580	1100
1819	1730	1200
1821	1880	1300
1823	2030	1400
1825	2180	1500
1827	2330	1600