



隆鑫通用动力股份有限公司
Loncin motor co., Ltd.

详细地址: 重庆市九龙坡区九龙工业园区华龙大道99号
Add: No.99Hualong Road, Jiulongpo District, Chongqing, China
Tel: 86 23 8980 5678/86 23 8980 8505
Fax: 86 23 8906 7566
Email: marketing@loncinengine.com
Website: www.loncinengine.com

PRINTED IN CHINA



Gasoline Generator

LC2500(D)-A • LC3000(D)-A • LC3500(D)-A

LC5000(D)-A • LC6500(D)-A • LC8000(D)-A

Owner's Manual



www.loncinengine.com

Loncin motor co.,ltd.

Save this operating manual properly and carry it with the generator for the convenience of emergency query in the future. This manual constitutes one permanent element of the generator. This manual shall be provided along with the generator set when you lend or resell it.

Relevant information and technical specifications defined in this manual take effect when printing is approved, with the contents based on the equipment in production at time of publication. Manufacturer reserves the rights to modify and improve any parts described in the text without prior notice.

Contents

1	Foreward	01
2	Safety Regulations	02-07
3	Glossaries	08-09
4	Parameters	10-11
5	Description of Spare Parts	12-15
6	Operation Method	16-21
7	Transporting	22
8	Accessories Installation	23-25
9	Powers of Common Appliances	26-27
10	Maintenance	28-31
11	Common Fault Analysis	32-33
12	Electrical schematic diagram	34-37

Foreward

Thank you for purchasing a generator. This air cooling device, powered by gasoline engine, is a household generator of compact structure and high performance. It is applicable to the situation of no electricity supply or sudden electricity cut.

We recommend that the operator read this manual carefully before use this generator, and fully comprehend all requirements and operating procedure concerning the generator. In case of any questions about this manual, contact the recent authorized dealer for startup, operation, maintenance program and so on. The technician will teach you how to use the generator in a correct and safe manner. We also recommend that the operator consult startup and operating procedure of this generator when buying it.



Safety precautions

This generator will work in a safe, effective and reliable way only when it is kept, operated and maintained properly. Before operation or maintenance of the generator, the operator should:

- Know well and strictly observe local laws and regulations.
- Read and observe all safety warnings in this manual and on the device.
- Let your family get familiar with all safety warnings in this manual.

It is impossible for manufacturers to predict all hazardous circumstances that may occur, for this reason, warnings in this manual and caution signs on the generator set may not cover all hazardous circumstances. If we do not give extra cautions for operating procedures, methods or techniques, operate the generator in such ways that helps guarantee personal safety, make sure no damage to generator set arises there from.

To make sure safe operation, Please read carefully three vital safety warnings in this manual and on the generator, preceded by a safety alert symbol  including:

 DANGER	You WILL be KILLED or SERIOUSLY HURT if you don't follow instructions.
 WARNING	You CAN be KILLED or SERIOUSLY HURT if you don't follow instructions.
 CAUTION	You CAN be HURT if you don't follow instructions.
NOTICE	Your generator or other property could be damaged if you don't follow instructions.

Safety Regulations

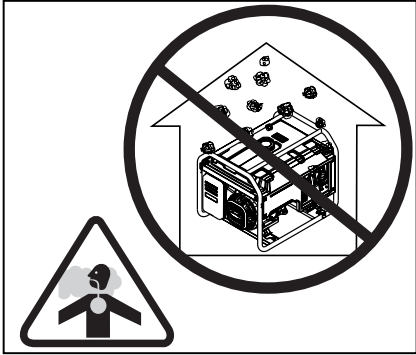

⚠ DANGER

Do not use it indoors.

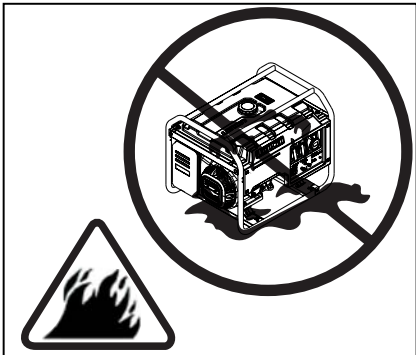

⚠ DANGER

Keep the machine clean and avoid spilt combustibles including gasoline on it.

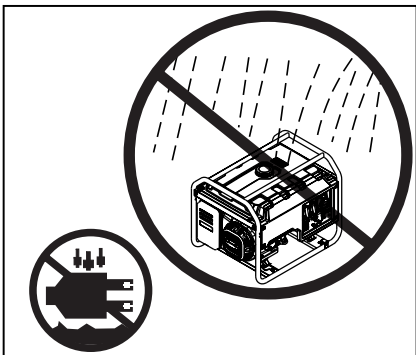

⚠ WARNING

Do not use it in a wet condition.

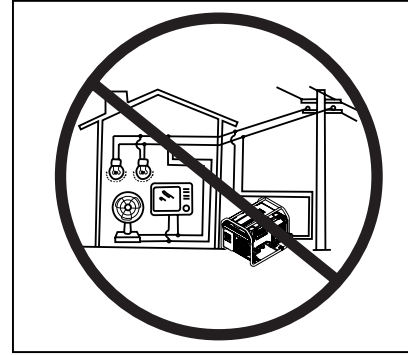

⚠ WARNING

Do not connect to a home power system.

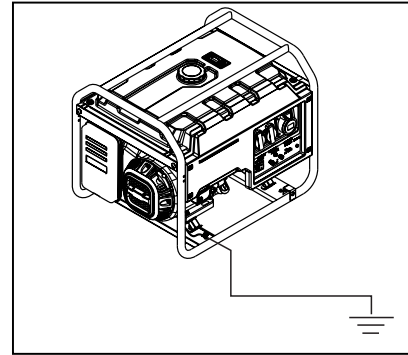

⚠ WARNING

It must realize safe grounding.

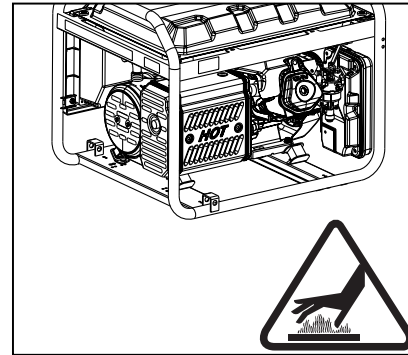

⚠ WARNING

The generator surface has high temperature, avoid scalding. Pay attention to the warnings on the generating set.

⚠ DANGER General safety information

- Operator should put on personal protective equipment during operation and maintenance.
- The installation and major repair work shall be carried out only by specifically trained personnel.
- Do not use the generator underground.
- Do not use the generator under an explosive condition.

⚠ DANGER The generator produces enough electric power to cause a serious shock or electrocution if misused.

- It is prohibited to use bare wire to connect power supply to the electric equipment directly, use the plug that fits local regulations.
- In equipment operation, do not touch wire or live parts of the equipment. Never touch the machine with wet hands or electrical shock will occur.
- In equipment operation, keep children certain safe distance from the generator.
- In equipment operation, strictly prohibit assembling and disassembling any parts.
- It is suggested to realize tandem connection of a ground fault circuit interrupter (GFCI) when the power supply is out to guarantee safety.
- External electric accessory (including cable and plug interconnecting piece) shall have no fault. Electric shock defend depends on the breaker, especially the matching between breaker and generator. During replacement of the breaker, only that with the same rating and performance features can be adopted. Contact local dealers or the after-sales service center for support.
- In case of using lengthening wire or mobile power distribution cabinet, overall length of the wire with cross section of 1.5mm² shall be no longer than 60m, and that of 2.5mm² shall be no longer than 100m.
- Avoid connecting the generator in parallel with any other generator.

⚠ DANGER Fuel of the machine is flammable, which will generate high temperature and easily cause fire during operation.

- It is strictly prohibited to add fuel during equipment operation.
- In case of adding fuel, keep far away from fire brand, no smoking.
- In case of adding fuel, do not spill fuel on the equipment.
- As to accidental spilling, use cotton cloth to clean it. Start the equipment after spilt fuel evaporates completely.
- In operation, make sure that there is no flammable substance within 2 meter range, and no flammable substance will approach the equipment. Avoid placing any flammable materials near the exhaust outlet during operation.
- In case of long-term nonuse, take out the fuel from fuel tank and store it safely.
- If you swallow any fuel, inhale fuel vapor, or allow any to get in your eyes, see your doctor immediately. If any fuel spills on your skin or clothing, immediately wash with soap and water and change your clothes.
- When operating or transporting the machine, be sure it is kept upright. If it tilts, fuel may leak from the carburetor or fuel tank.
- Do not throw the residue fuel and used motor oil into the trash or pour it onto the ground. We suggest you take used oil in a sealed container to your local recycling center or service station for reclamation.

⚠ CAUTION This equipment contains high speed revolving parts, which will harm human body.

- In equipment operation, do not approach it and strictly prohibit touching revolving parts.
- In equipment operation, do not lift or move it. Move it only after equipment completely stopped.
- In equipment operation, observe surroundings. Make sure no articles are involved into the equipment.





NOTICE

Operating requirements

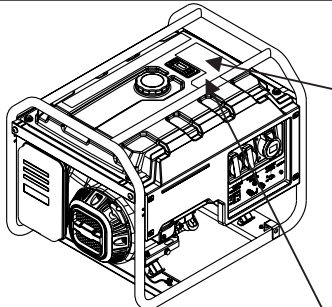
- Do not place heavy weight on the equipment.
- The wheel is for easy moving of the equipment. Do not use it for long distance moving, otherwise it will be damaged.
- Do not exceed rated power of the equipment in operation; otherwise, its service life will be shortened. Power of common household appliances is shown on Page 26,27 in details.
- Pls maintain the equipment according to the requirements so as to prolong its service life. Refer to Page 28 for details.
- Prevent duct from entering into the equipment during operation or storage.

There is the warning label on the machine to remind you of the safety regulations.



⚠ WARNING		
 <p>Read owners manual carefully for important safety and health warnings and instructions.</p> <ul style="list-style-type: none"> ▪ Understand and follow warnings and cautions. ▪ Do not operate unless guards are in place. 	 <p>Generators produce electricity that can cause serious injury or death. Operate only in dry areas away from moisture, rain, snow or standing water.</p>	
 <p>Generator exhaust contains hazardous CO. Do not operate indoors and try to operate in well ventilated area.</p>	 <p>Due to high voltage of Generator</p> <ul style="list-style-type: none"> ▪ Do not connect to any building electrical system. ▪ Do not overload generator. ▪ Non-qualified person (including under-aged children) is not allowed to operate. 	
 <p>Gasoline and its vapor are flammable and explosive. Keep gasoline away from heat, sparks, and flame sources.</p>		





GASOLINE FUEL ONLY



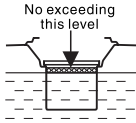

⚠ DANGER

Using a generator indoors CAN KILL YOU IN MINUTES. Generator exhaust contains carbon monoxide. This is a poison you cannot see or smell.

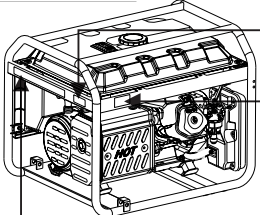
<p>⚠ WARNING</p> <p>No exceeding this level</p>  <p>Do not overfill tank always allow room for fuel expansion. Do not fill while running.</p>	   <p>NEVER use inside a home or garage. EVEN IF doors and windows are open.</p> <p>Only use OUTSIDE and far away from windows, doors, and vents.</p>
---	--















⚠ WARNING	
	<p>A hot exhaust system can cause serious burns.</p> <ul style="list-style-type: none"> ▪ Avoid contact if the engine has been running.

 LWA 97 dB	 Generating set EN 12601		<h1>6500-A</h1>	
	Rated Power COP	5.0kW	50 Hz	G1 Class A
	Power Factor	1.0	230V	IP23M
	Year of Mfg.	XXXX	21.7A	Mass 80kg

Glossaries

Following symbols are quoted on the machine or in this manual. Please understand their meaning, which will make your operation easier and safer.

Symbol	Name	Meaning
V	Volt	Voltage
A	Ampere	Current
Hz	Hertz	Frequency (1Hz=60 r/min)
W	Watt	Power
RPM	Revolutions per Minute	Engine Speed
PF	Power factor	Load transfer efficiency
G1	Performance rate	Generator output power performance rate meet ISO8528G1
	Read instructions	Please read instructions carefully before use
	Safety warning	Can be hurt if not follow instructions
	Electric risk	Indication of electrified body. Pay attention to safety.

Symbol	Name	Meaning
	Toxic gas	Exhaust from the equipment contains CO, which is invisible and inodorous. Excessive suction of CO may make human lose consciousness and lead to death in serious situation.
	Electric shock	This is electric device. You may suffer electric shock if you don't follow the instructions.
	Electriferous, no touching	The device is electriferous. No touching during operation.
	Fire	Fuel and high temperature generated during operation may cause fire. Operate it cautiously.
	Explosion	Fuel tank may explode when encountering high temperature and open fire. Operate it cautiously.
	Scalding	Some parts of equipment will generate high temperature during operation, which will scald skin.
	Grounding symbol	Make the machine realize safe grounding before use
	No raning	Do not use the plug or electric device in the rain or make them get wet.
	Engine oil	Symbol of adding the engine oil and the specification is specified on Page 16
	Fuel	Symbol of adding the fuel, which must be gasoline.

Parameters

Model	2500-A 2500D-A	3000-A 3000D-A	3500-A 3500D-A	5000-A 5000D-A	6500-A 6500D-A	8000-A 8000D-A
AC output						
Frequency	50 /60Hz (subject to the parameter label on the equipment)					
Voltage	120/220V/230V(subject to the parameter label on the equipment)					
Rated power(kW)※	2.0	2.3/2.5⊙	2.8/3.0⊙	4.0	5.0	6.0/6.5⊙
Max. power(kW)★	2.2	2.5/2.8⊙	3.1/3.3⊙	4.5	5.5	6.5/7.0⊙
Engine						
Specification	Single cylinder, forced air cooling, 4 strokes					
Rpm	3000(50Hz)/3600(60Hz) (subject to the parameter label on the equipment)					
Fuel	Gasoline					
Engine oil capacity	0.6 L			1.1 L		
Spark plug type	F7TC/F7RTC (N9YC/RN9YC)					
Spark plug clearance	0.7 mm					
Valve clearance (inlet/outlet)	0.10/ 0.15 mm					
Igniting Mode	T.C.I.					
Starting mode	Recoil start / Electric start					
Displacement	196cc	196cc	210cc	337cc	389cc	420cc
Weight (only for reference)						
Net weight	40/42kg△	44/46kg△	47/49kg△	73/75kg△	77/79kg△	81/83kg△
Overall dimensions (excluding packing box)						
L x W x H (mm)	590x430x467			681x546x566		
Capacity of fuel tank	15L			25L		

Noise(according to European Directive 2000/14/EC with amendment 2005/88/EC)						
Model	2500-A 2500D-A	3000-A 3000D-A	3500-A 3500D-A	5000-A 5000D-A	6500-A 6500D-A	8000-A 8000D-A
Measured Sound Pressure Level	73 dB(A)	74 dB(A)	74 dB(A)	75 dB(A)	75 dB(A)	75 dB(A)
Measured Sound Power Level	93 dB(A)	94 dB(A)	94 dB(A)	95 dB(A)	95 dB(A)	95 dB(A)
Uncertainty	2 dB(A)	2 dB(A)	2 dB(A)	2 dB(A)	2 dB(A)	2 dB(A)
Guaranteed Sound Power Level	95 dB(A)	96 dB(A)	96 dB(A)	97 dB(A)	97 dB(A)	97 dB(A)

※ For continuous operation,do not exceed the rated power.

★ Limit operation requiring maximum power to 30 minutes.

⊙ 2.8/3.0 means: 2.8kW with 50Hz, 3.0kW with 60Hz.

△ 40/42kg means: The net weight is 40Kg for recoil start.
The net weight is 42Kg for electric start.

Description of Spare Parts

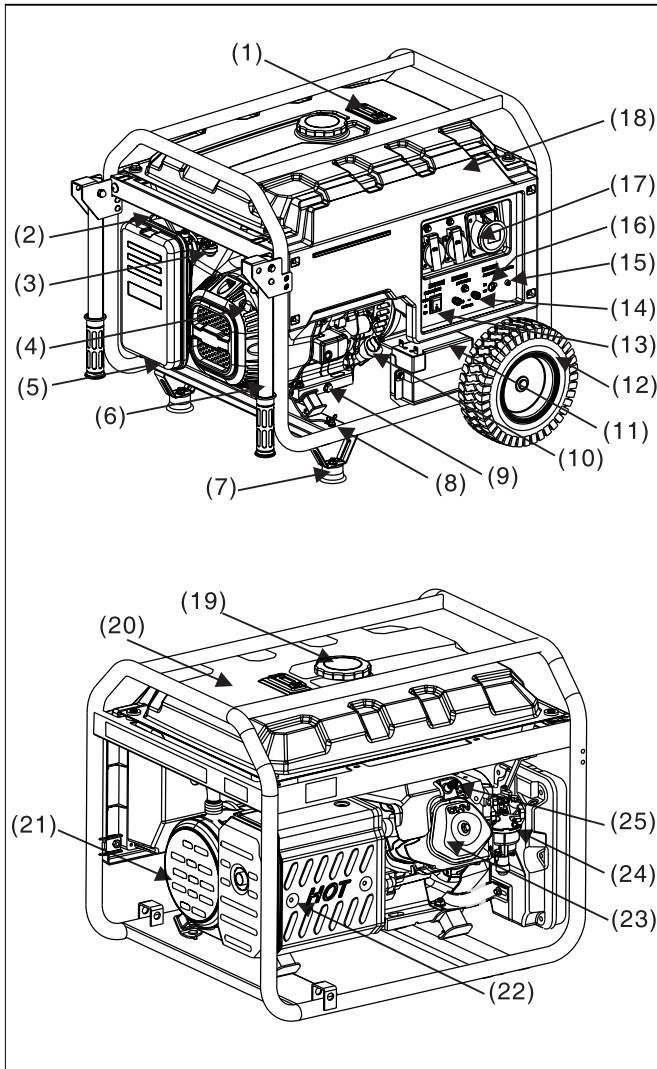

- (1) Fuel gauge
- (2) Chock valve
- (3) Fuel valve lever
- (4) Starter Grip
- (5) Air cleaner
- (6) Handrail pipe
- (7) Foot
- (8) Ground terminal
- (9) Oil drain bolt
- (10) Oil filler cap
- (11) Battery (optional)
- (12) Wheel
- (13) Engine switch
- (14) DC output
- (15) Output indicator
- (16) AC circuit breaker
- (17) AC output
- (18) Panel seat
- (19) Fuel tank cap
- (20) Fuel tank
- (21) Cover,Generator End
- (22) Muffler
- (23) Cylinder head
- (24) Carburetor
- (25) Spark plug

Fuel tank	It is used to hold fuel, gasoline is allowed only.
Fuel tank cap	Screw the fuel injection port in use and do not open it in equipment operation.
Fuel gauge	It is to indicate fuel level in the fuel tank.
AC output	AC output socket provides the power supply.,Pls refer to model's parameter table for its rated power. load of each socket cannot exceed its rated current, and total power of electric device cannot surpass rated power of the generator. Do not start up several electric devices simultaneously, but switch on another one after stable operation of one electric device.
AC circuit breaker	It will break to protect the electric device when current is too heavy.
Output indicator	It is to indicate power supply status. The indicate will brighten up when the equipment operation.
DC output	The output DC is 12V with maximum of 8.3A. It is only used for automative battery charging with rated 12V. Pay attention to connecting the positive and negative electrode correctly.
Engine switch	It is to start up (applicable to electrical starting only) and switch off the engine.Turn to the off state in nonuse.
Wheel (optional)	It is for moving the generator in a short time.
Battery (optional)	It is for starting up the generator, In case of nonuse for three months, charge it.



Description of Spare Parts

Portable Gasoline Generator Operating Instructions

Oil filler cap	It is for measurement of engine's oil level. Make sure engine's oil level is between MIN and MAX in the dipstick of oil filler cap before use. Oil can be added after removing the oil filler cap.
Oil drain bolt	Unscrew this bolt when replacing the engine oil. Drain out the old engine oil and dispose of it properly according to local laws, avoiding damage to the environment.
Foot	It is to support the generator.
Grounding terminal	It is to make the generator realize safe grounding. As to the grounding method, refer to the Page16. Make sure unobstructed grounding before use.
Handrail pipe	After lifted up, the pipe, with self-locking structure, can be used to move the generator.
Starter Grip	It is to start up the engine. For the method, refer to the Page 19.
Air cleaner	It is to filter air and remove impurities in the air entering cylinder . As to the maintenance method, refer to Page 29.
Fuel switch	It is to control fuel's entering into the engine via fuel tank. During nonuse of generator, leave the switch off.
Choke valve	It is to control air flow into the cylinder when starting up the engine. As to the operating method, refer to the Page 19.
Muffler	It is to eliminate noise during equipment operation, and discharge high temperature exhaust of engine's combustion. Do not touch it to avoid scalding.



Description of Spare Parts

Portable Gasoline Generator Operating Instructions

Sockets can be following patterns according to relevant regulations in various areas:

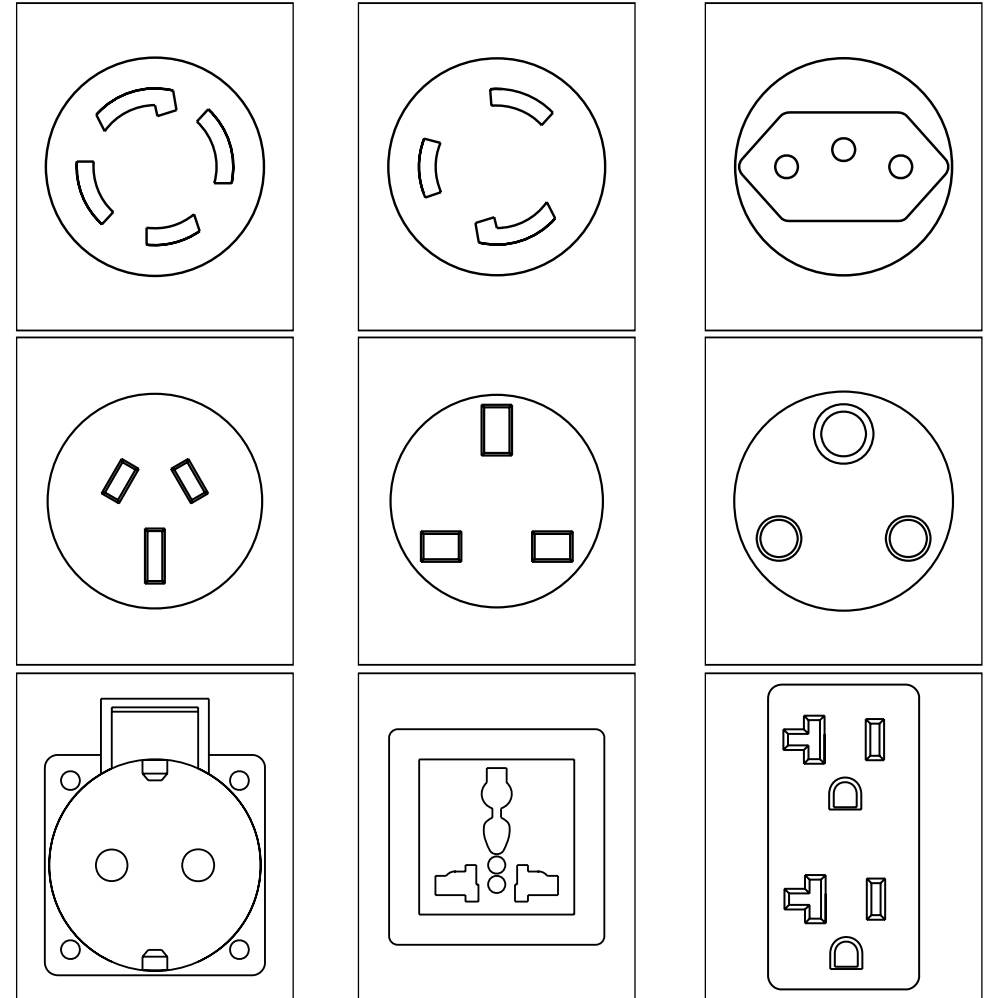

⚠ WARNING

When the rated current from one socket output more than the socket 's nominal rated current , you should to use simultaneously two or more sockets for power output.

Operation Method

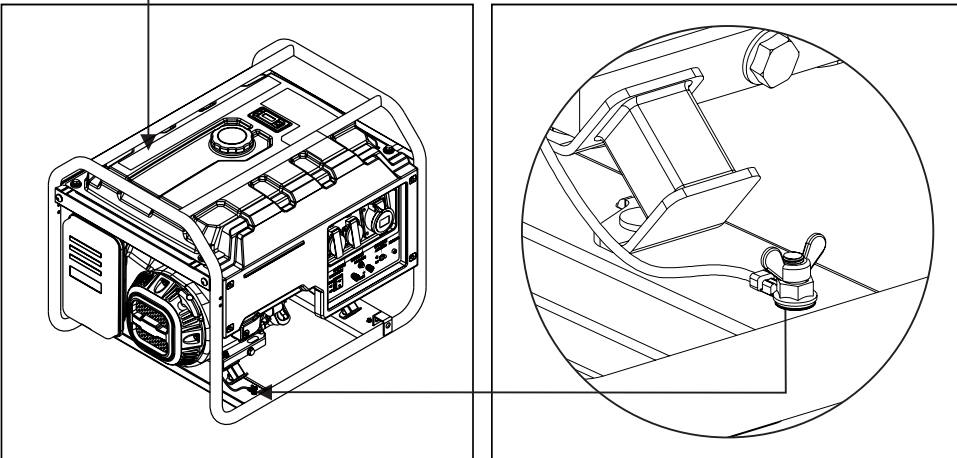
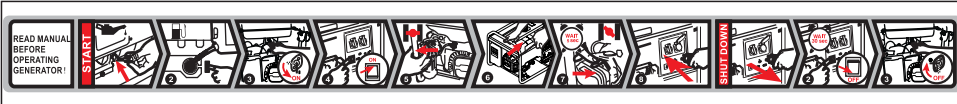

● Unit grounding

Shift the machine outdoors, use wire of no less than 2.5mm² to make the machine and grounding terminal connected to the ground. One end of the wire is pressed below the butterfly nut of the unit, screwed up tightly, and the other end is connected with the metal rod shape article (such as the iron nail and the opener), and inserted into soil.

● Starting the generator set

Filling oil

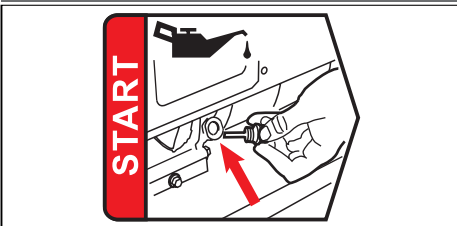

Remove the oil filler cap, fill oil of proper model. As to dosage, refer to Page 10. Use the funnel for filling, in case of careless spilling, clean the ground to avoid slipping.

oil specification table

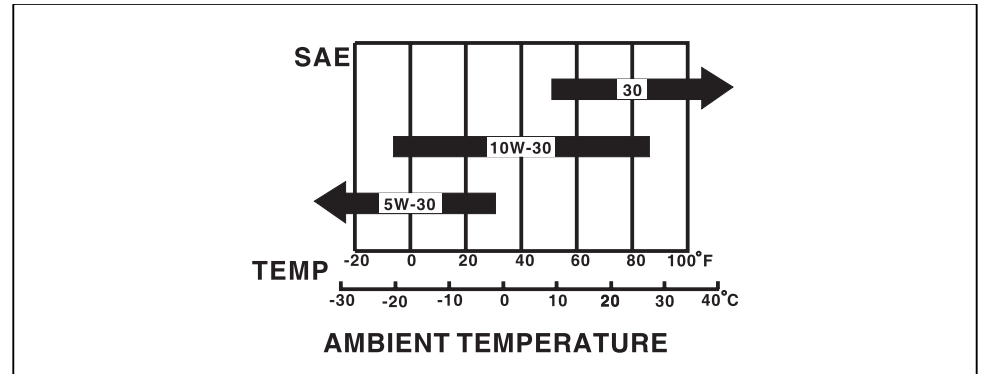

Filling fuel

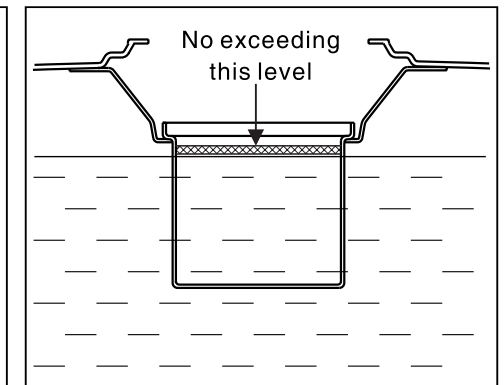
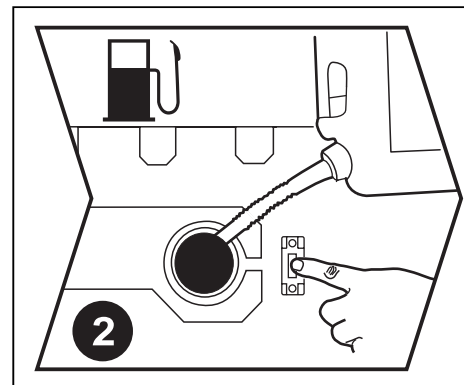

Open the fuel tank cap and fill gasoline, the fuel leveler's position will display gasoline mass in the fuel tank and take care the maximum fuel position shall not exceed the inner strainer of the tank when filling.

⚠ WARNING Keep away from the fire source and heat source when filling; do not fill gasoline when be operating.

6

Operation Method

Portable Gasoline Generator Operating Instructions

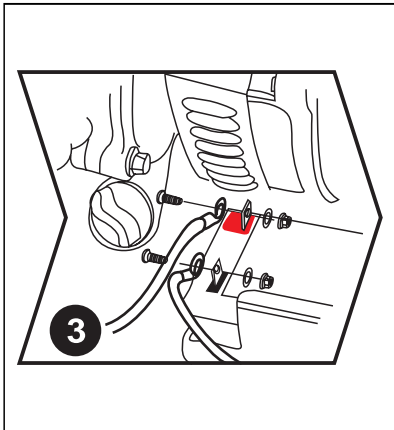

Connect electric battery (electric start only)

Connect the storage battery wire to the storage battery, red for positive electrode and green for the negative electrode, and make sure screwing the nut tightly. Not contact between positive electrode to negative electrode to avoid short circuit. After connection, metal parts of two pieces of wire shall keep at least 15mm safety distance, and be protected by rubber cover.

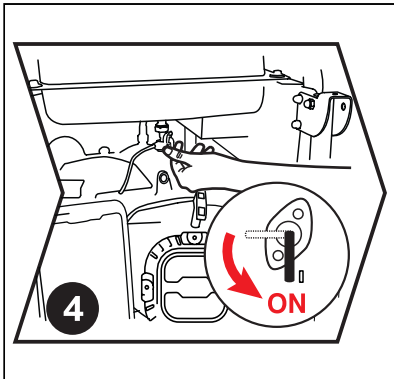

Turn on the fuel valve lever

Turn the fuel valve lever to ON and let the fuel flow into the carburetor.

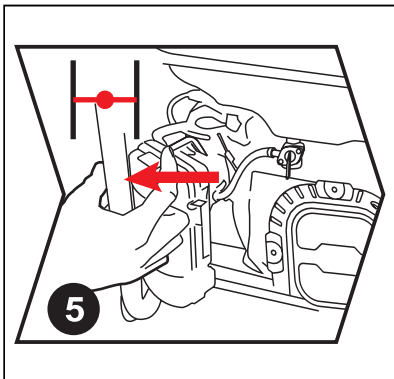

Close the choke valve

When the unit is in cold state, move the choke valve to the full closed position, and half closed position in thermal state. If the generator unit is not started for two times in succession, move the choke valve to the open position and then to operate the switch or hand-pull starter.

6

Operation Method

Portable Gasoline Generator Operating Instructions

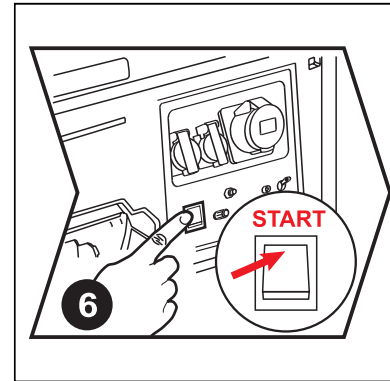

Start the generator

Turn the engine switch on the control panel to ON. Or press it to START if it's electrical start state, then generator unit can be started. In order to extend the service life of the storage battery, do not press on the switch for more than 3 seconds and the interval between two pressings should be longer than 10 seconds.

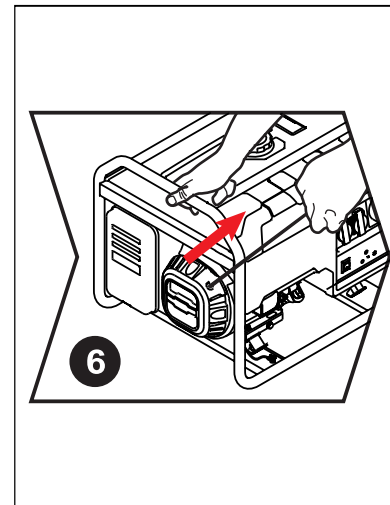

Start the generator recoil start

Start via the pull wire: Pull the wire gently to connect the disc to the starting bowl inside the unit. Pull the wire out in an instant action and the generator unit will be started after doing this twice. If it is not started, please conduct the above operation with the choke valve.

⚠WARNING

It may be causing the dangers of injury by the sudden change of rotation direction of the engine during operating the recoil starter.

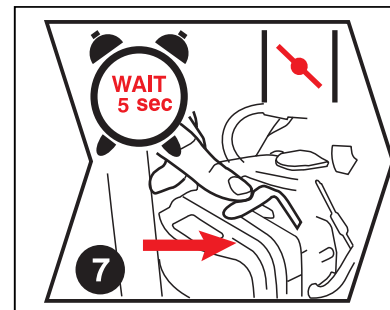

Open the choke valve

After starting, let the unit run without load for 5 seconds and then turn on the choke valve switch.

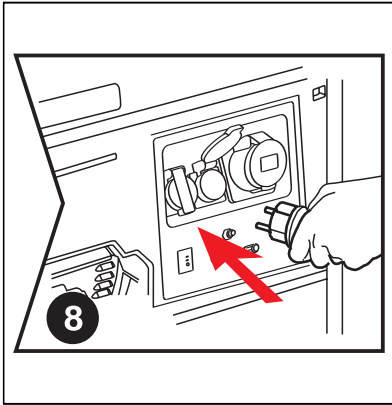

Connect to load

Access electric equipment and turn the circuit breaker to ON. Please note that when several loads are used at the same time, do not access the next one unless the former one is running normally. The total power of the loads should not exceed the rated power of the unit.

● Shut down the engine

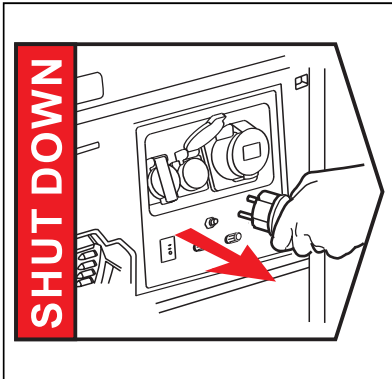

Disconnect load

Disconnect the electric equipment from the control panel of the generator.

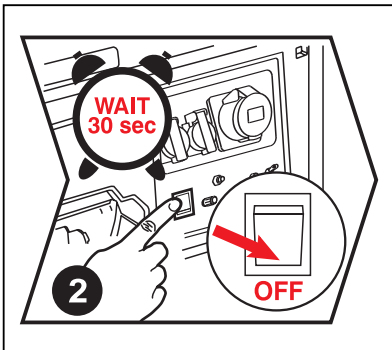

Turn off the engine switch

After 30 seconds of no-load running, turn off the engine switch and the generator unit will be shut down immediately.

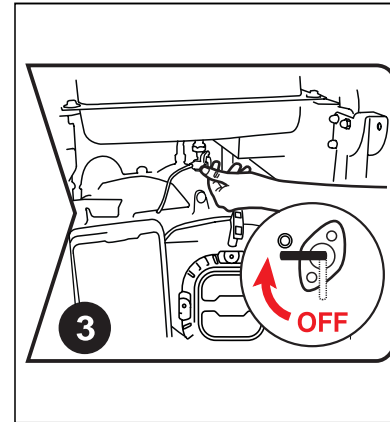

Close the fuel valve lever

Turn off the fuel valve lever after the shutdown of the unit.

⚠ WARNING

The surface temperature of the generator unit is still high after shutdown, and it can not be moved or operated before cooling down in order to avoid scalding.

● Storage

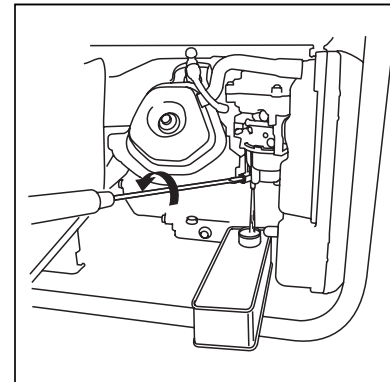

Drain the fuel

Remove the oil draining bolt of the carburetor and drain the fuel from the fuel tank and carburetor. Then tighten the oil draining bolt again (if the fuel is not drained, the fuel will evaporate and flow into the air, and the residues may block the carburetor).

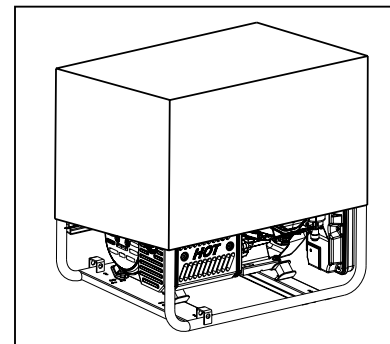

Protective treatment

The unit should be stored in a clean and dry place and should be protected from rain and high temperature. Shield the unit with paper box or plastic bag to prevent dust from entering the unit.

Transporting

To prevent fuel spillage when transporting or during temporary storage, the generator should be secured upright in its normal operating position, with the engine switch OFF.

The fuel valve lever should be turned OFF.

⚠ WARNING

When transporting the generator:

- Do not overfill the tank.
- Do not operate the generator while it is on a vehicle. Take the generator off the vehicle and use it in a well ventilated place.
- Avoid a place exposed to direct sunlight when putting the generator on a vehicle. If the generator is left in an enclosed vehicle for many hours, high temperature inside the vehicle could cause fuel to vaporize resulting in a possible explosion.
- Do not drive on a rough road for an extended period with the generator on board. If you must transport the generator on a rough road, drain the fuel from the generator beforehand.

NOTE:

To transport the generator, hold the holding part (shaded areas in the figure 1).

Take care not to drop or strike the generator when transporting.

Do not place heavy objects on the generator.

When transporting the generator by loading it on to a vehicle, secure to the generator frame as shown (See figure 2).

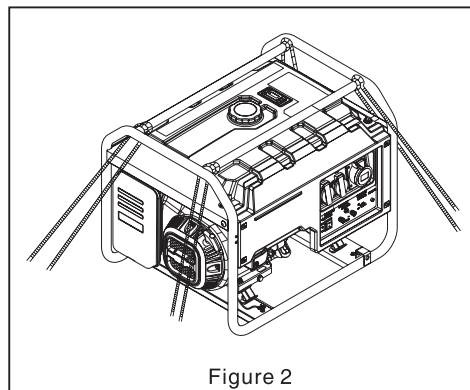
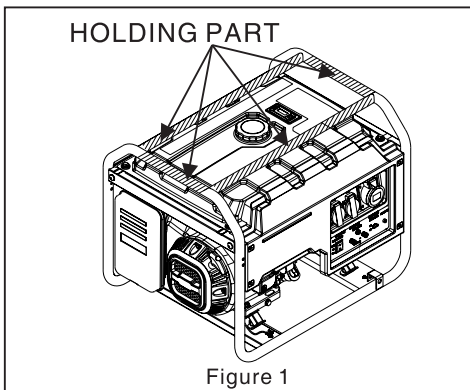

Accessories Installation

You can install the wheel assemblies for the convenience of moving the unit.

You may need to prepare the following equipment before the installation.

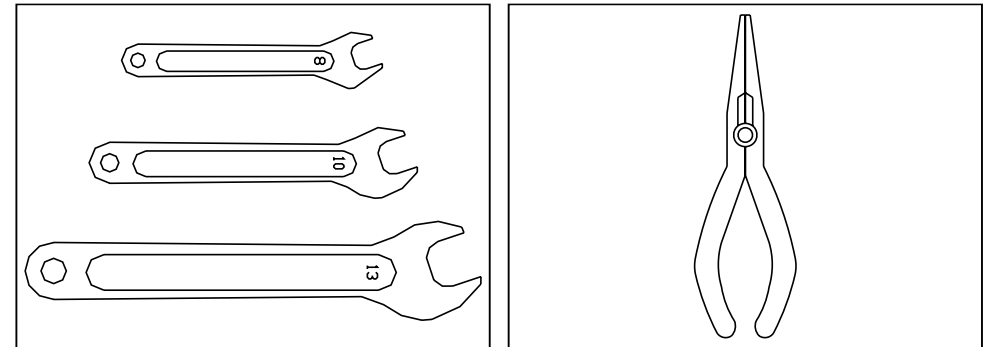

According to the different model configurations, there are several kinds of wheels. Please install the handrail, vibration reduction bracket and wheel on the base plate and tighten the bolt as shown in the following picture.

- **Two-wheel short axle (applicable to generator units of 5000-A~8000-A series)**

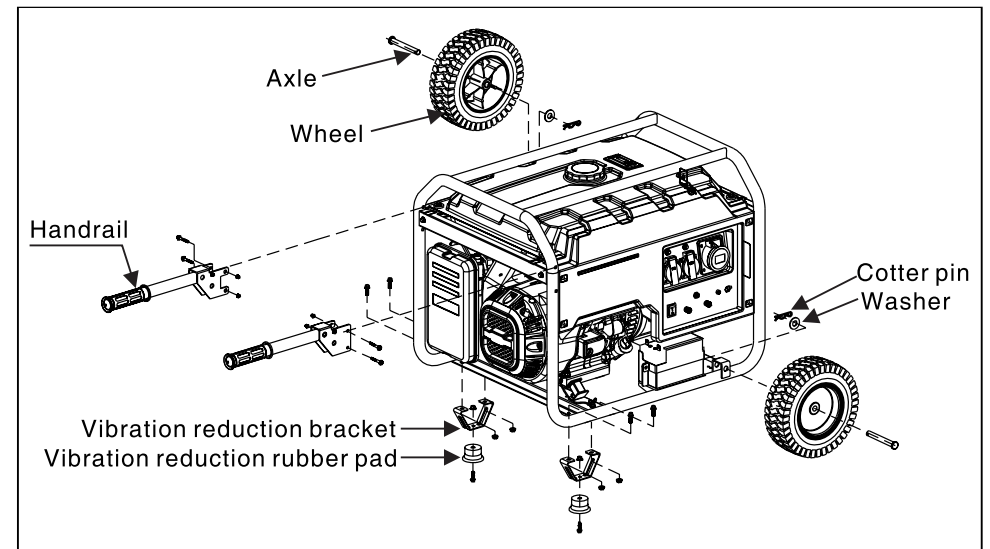

- **Two-wheel long axle (applicable to generator units of 2500-A~3500-A series)**

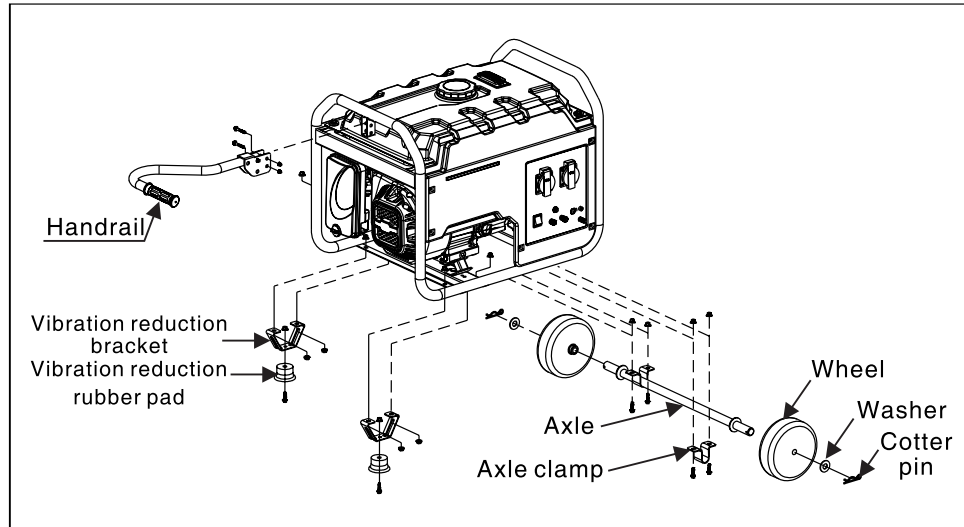

- **Four-wheel long axle (applicable to generator units of 2500-A~8000-A series)**

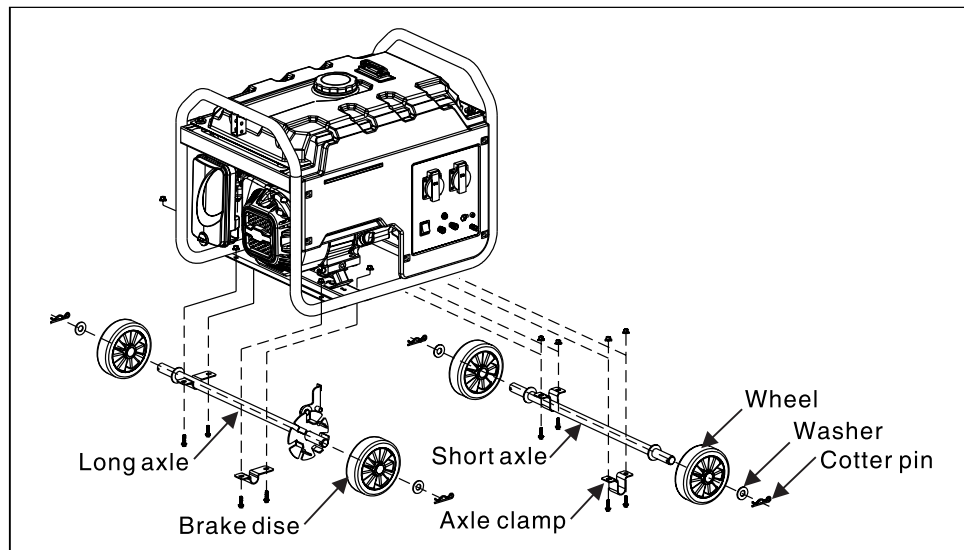

Some of the units, which are of the electrical starting type, need to be equipped with external storage battery bracket. Please conduct the installation according to the following drawing.

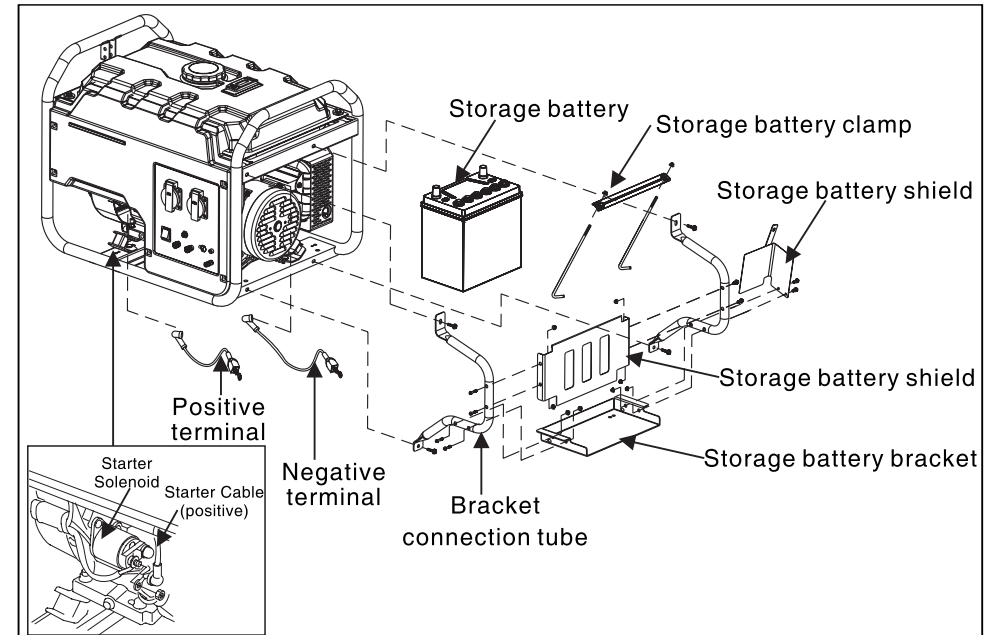

Operating steps and installation instructions:

- 1 Install the positive terminal and negative terminal onto the generator unit as specified in the drawing.
- 2 Install the storage battery bracket onto the bracket connection tube.
- 3 Install the storage battery shield onto the bracket connection tube.
- 4 Install the assembled bracket onto the unit.
- 5 Put the storage battery into the bracket.
- 6 Hook the hook bolt to the hole of the bracket, and install it onto the storage battery clamp.
- 7 Tighten the bolt and install the storage battery onto the bracket.
- 8 Connect the storage battery wires and connect the negative one first. The connected terminals may be different as the models of the storage batteries are different. Take material object as.
- 9 Some storage batteries need to be filled with electrolyte before installation. Please read the specification of the storage battery carefully.

Powers of Common Appliances

Electric equipment		Rated power(W)	Starting power(W)	
Household Appliances	Flat panel television 27"		120	120
	Energy saving lamp		5~50	5~50
	Electric cooker		1000	1000
	Computer		400	400
	DVD		100	100
	Refrigerator		50	300

Electric equipment		Rated power(W)	Starting power(W)	
Household Appliances	Washing machine		250	500
	Electric fan		50	100
	Air-conditioner 2HP		1600	3200
Tools	Electric welder		2500	5000
	Electric hammer		1000	1500
	Water pump		800	1200

The starting powers of the appliances are far more higher than the operation powers. Please read the labels of the electric equipment for reference. The total power of the loads should not exceed the rated power of the generator.

Maintenance

Good maintenance is the best guarantee of safe, economical and fault-free operation. And it also contributes to environmental protection.

Maintenance schedule is as follows:

Schedule for regular maintenance		Per use	Every 20 hours or in the first month of initial use (3)	Every 50 hours or every 3 months (3)	Every 100 hours or every 6 months (3)	Every 300 hours or every year (3)
Engine oil	Inspect the oil level	○				
	Replace		○		○	
Air cleaner	Inspect	○				
	Clean			○ (1)		
Fuel switch sediment cup	Clean				○	
Spark plug	Clean				○	Replace
Valve clearance	Readjust					○ (2)
Cylinder head	Wash		Every 300 hours (2)			
Fuel tank and strainer	Wash		Every 2 years (2)			
Fuel tube	Replace		Every 2 years (2)			

(1) Maintenance should be conducted frequently if the unit is used in dusty places.

(2) Maintenance should be conducted by the franchised dealer.

(3) When the unit is used frequently, please conduct the maintenance according to the above mentioned intervals so as to ensure the long-term usage of the generator.

● Replace the engine oil

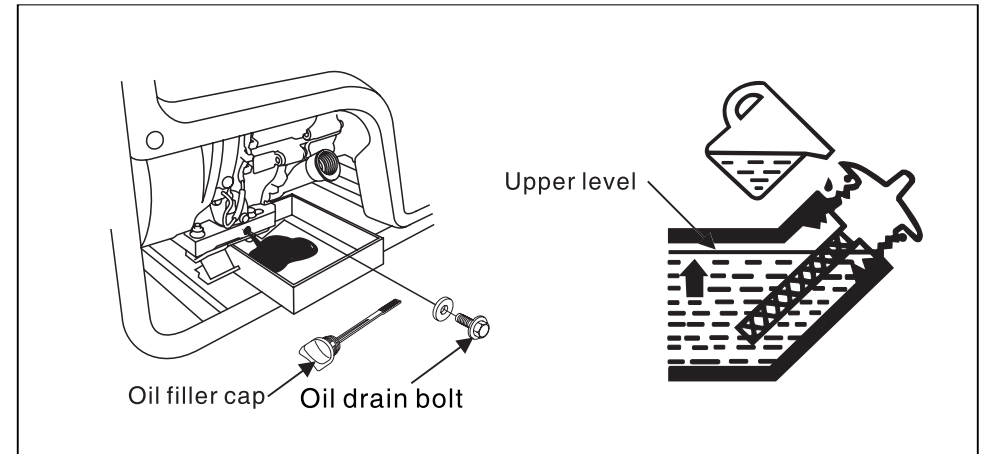

Remove the oil draining bolt and drain the long time stored oil. Tighten the oil draining bolt and twist off the oil dipstick. Fill in appropriate amount of oil via the oil dipstick and keep the oil level between MIN and MAX.

● Clean the air cleaner

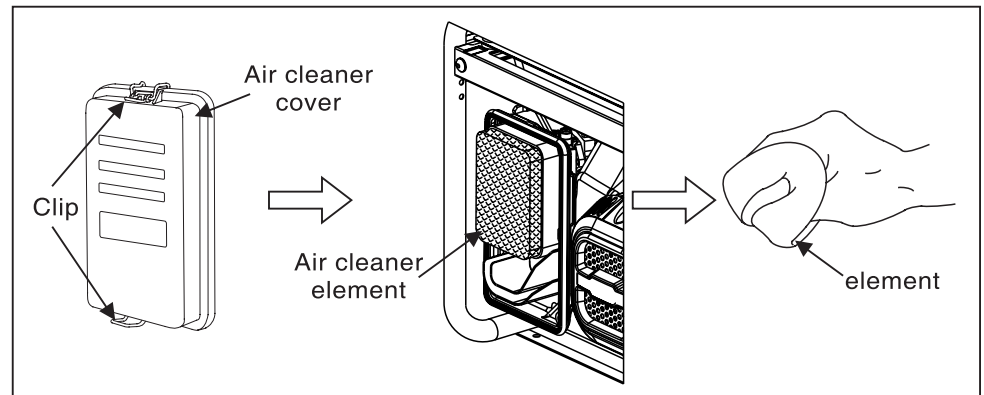

1 Remove the clip of the air cleaner cover and open it.

2 Inspect the air cleaner element and ensure that it is sound and clean.

3 If the foam cleaner element is dirty, spray some household cleaning agent onto the cleaner element. Scrub it for several minutes and rinse it with warm water. If the cleaner element is damaged, please replace a new one.

● Clean the fuel valve lever sediment cup

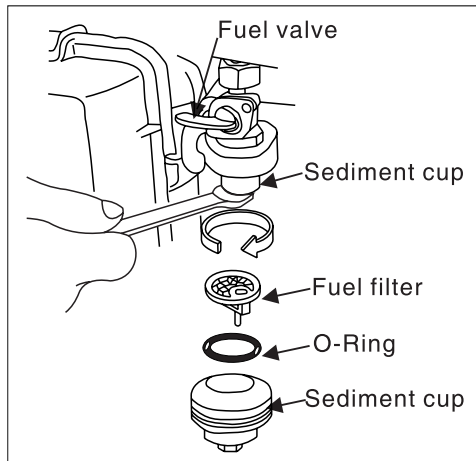

1. Close the fuel valve and remove the sediment bowl. Take out the O-type seal ring and strainer.
2. Clean the sediment bowl, O-type seal ring and strainer with incombustible or high-flash solvent.
3. Reinstall the O-type seal ring and strainer, and tighten the sediment bowl.
4. Open the fuel valve and inspect for leakage.

● Clean the spark plug

Recommended spark plug models: F7RTC and F7TC

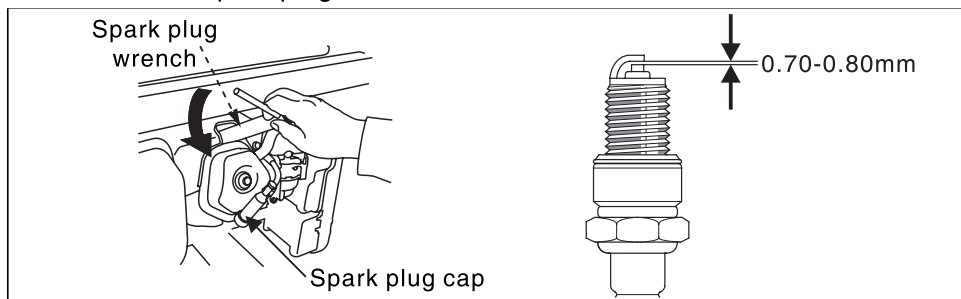

- 1 Remove the spark plug cap.
- 2 Clean the spark plug base.
- 3 Remove the spark plug with the spark plug socket spanner.
- 4 Inspect the spark plug insulator visually for damage. If it is damaged, replace a new one.
- 5 Measure the spark plug gap with a gap gauge. Twist the side electrode to adjust the gap. The gap should be kept between 0.70 and 0.80mm.
- 6 Inspect if the washer of the spark plug is in good condition.
- 7 Reinstall the spark plug and tighten it with the spark plug socket spanner. Press down the washer of the spark plug and place the spark plug cap.

● Valve clearance

(should be conducted by a professional person)

Figure 1 applicable to 2500-A, 3000-A, 5000-A, 6500-A, 8000-A, 2500D-A, 3000D-A, 5000D-A, 6500D-A, 8000D-A.

Figure 2 applicable to 3500-A, 3500D-A.

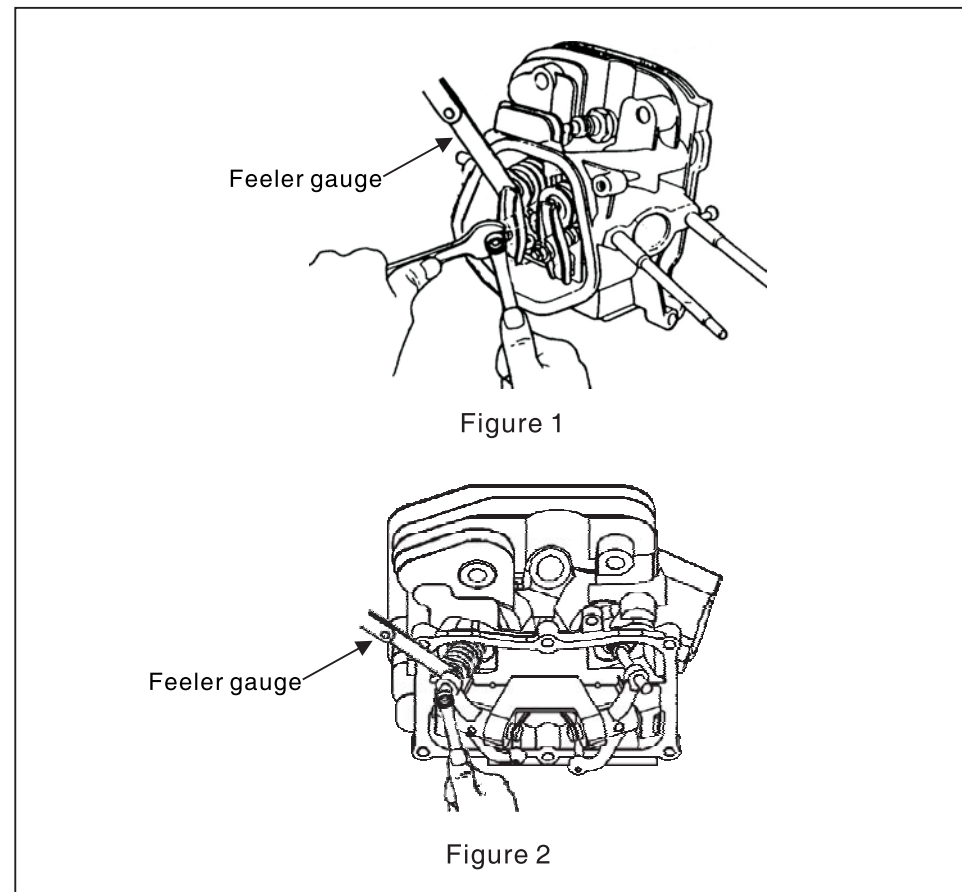

Remove the cylinder head cover and measure the valve clearance with the feeler gauge. The clearances are 0.1mm for the inlet valve and 0.15mm for the outlet valve.

Common Fault Analysis

Fault phenomenon	Fault cause	Operation method
The generator can not start	No fuel	Fill the oil tank with gasoline
	The oil switch is not turned on	Turn the oil switch to ON
	The oil switch is blocked	Clean the oil cup (refer to page 30)
	No engine oil or the engine oil level is low	Add oil
	The shutdown switch is turned off	Turn the switch to the "on" position
	The spark plug fails	Clean or replace the spark plug (refer to page 30)
no power output	The circuit breaker is not connected	Turn the circuit breaker to the "on" position
	The plug is poorly contacted	Replace a socket
Vibration while operation	The choke position is incorrect	Move the choke to the "on" position during operation
Vibration while operation	The temperature of the engine is too low	Let the engine run at empty load for more than 10 minutes
	The fuel oil is contaminated	Replace clean oil
The generator emits black smoke	The air filter is dirty	Clean the filter element of the air filter
	The load is too high	Reduce load to the rated limit
The generator emits blue smoke	The engine oil is too much	Drain some oil
	The engine oil type is incorrect	Choose appropriate engine oil type (refer to page 17)
The power decreases	The spark plug fails	Clean or replace the spark plug (refer to page 30)
	The valve clearance is out of limits	Adjust the valve clearance (refer to page 31)

- The environmental requirements of the generator:
- Suitable temperature: -15°C – 40°C .
- Suitable humidity: lower than 95%.

- Suitable altitude: under 1,000 meters (it should be used with lower power in districts higher than 1,000 meters.).
- The generator set can only be loaded to the rated power under the specified environment conditions. If the environment conditions are inconsistent with the above standards, or if the cooling conditions of the engine and generator set are defective; for example, when running in limited areas, it is necessary to reduce the power. It is also necessary to reduce the power when the temperature, altitude and relative humidity exceed the standards.
- If there is no problem with the conditions above, please turn to the nearby dealer or after-sales service center for consultancy.

Electrical schematic diagram

- **Electrical schematic diagram 1**
(applicable to 2500-A~3500-A)

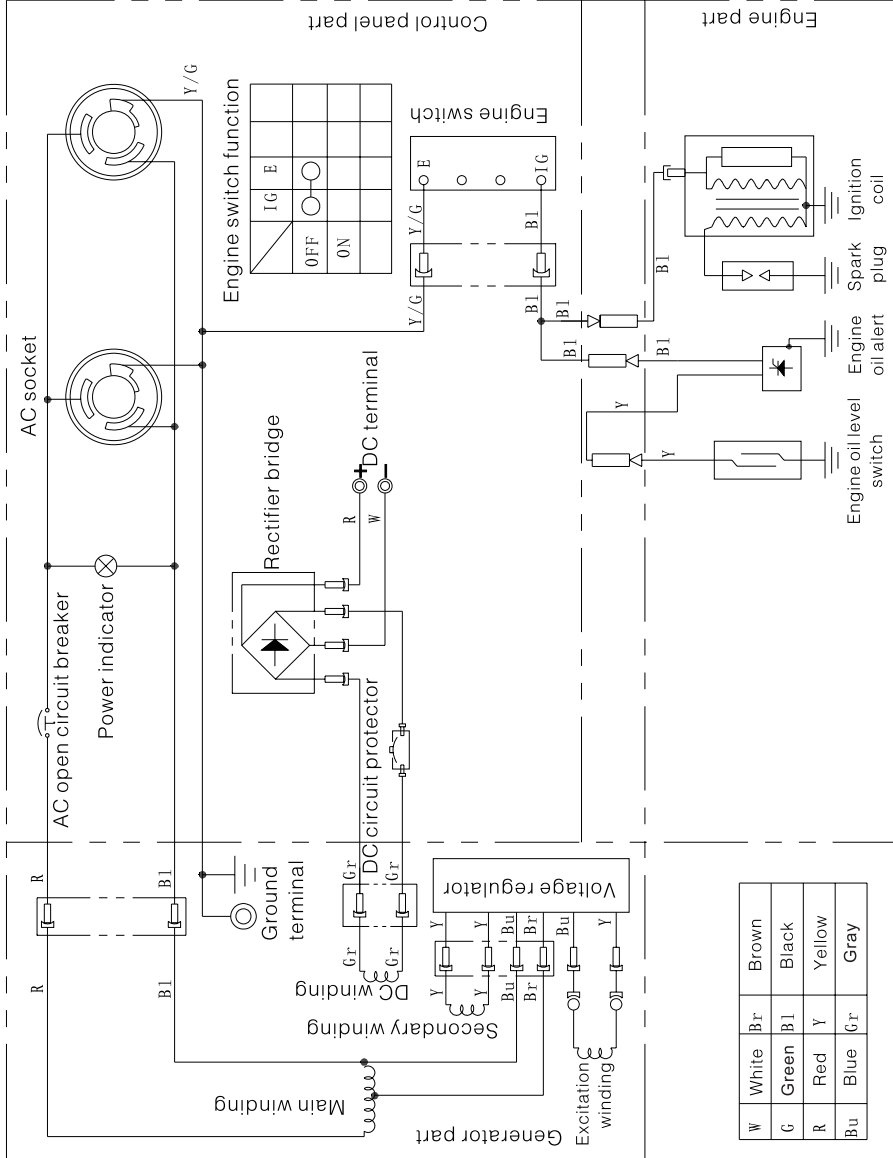

- **Electrical schematic diagram 2**
(applicable to 2500D-A~3500D-A)

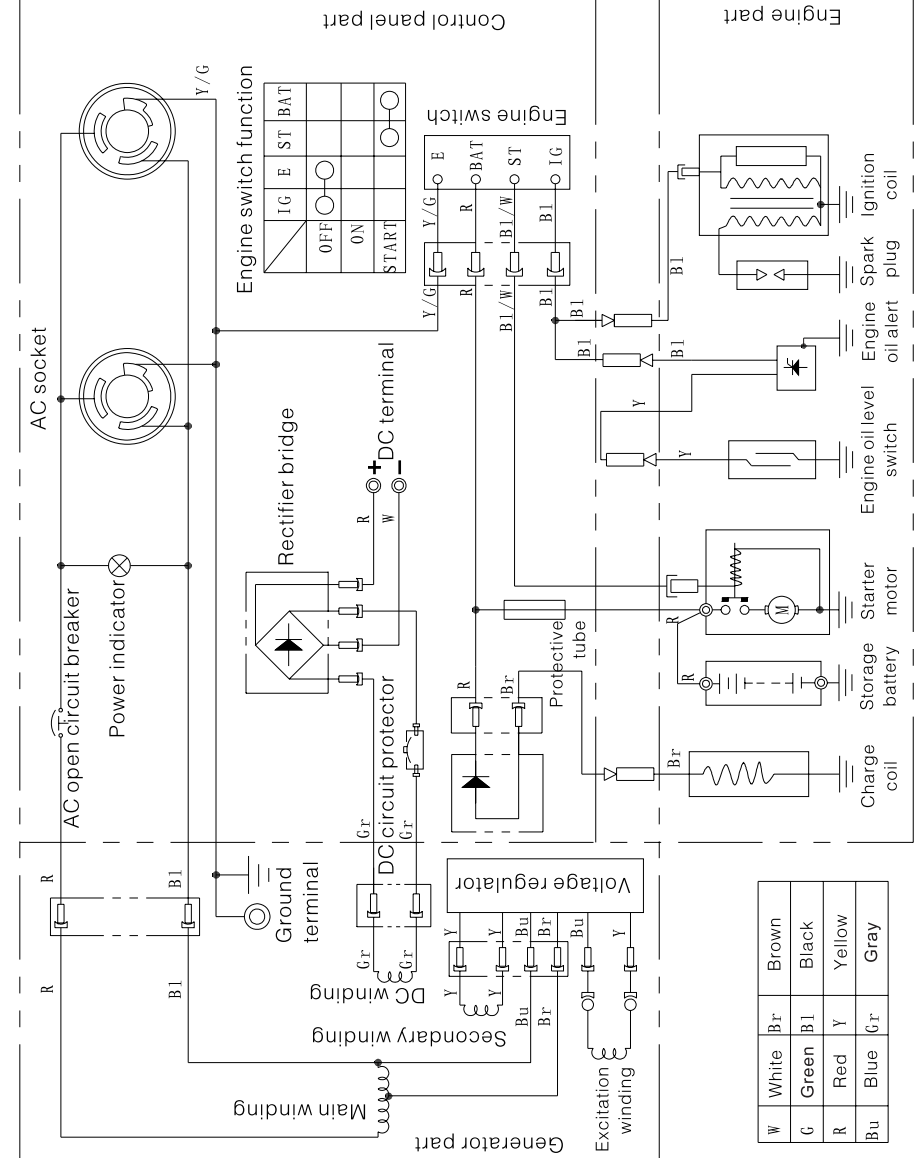

● Electrical schematic diagram 3
(applicable to 5000-A~8000-A)

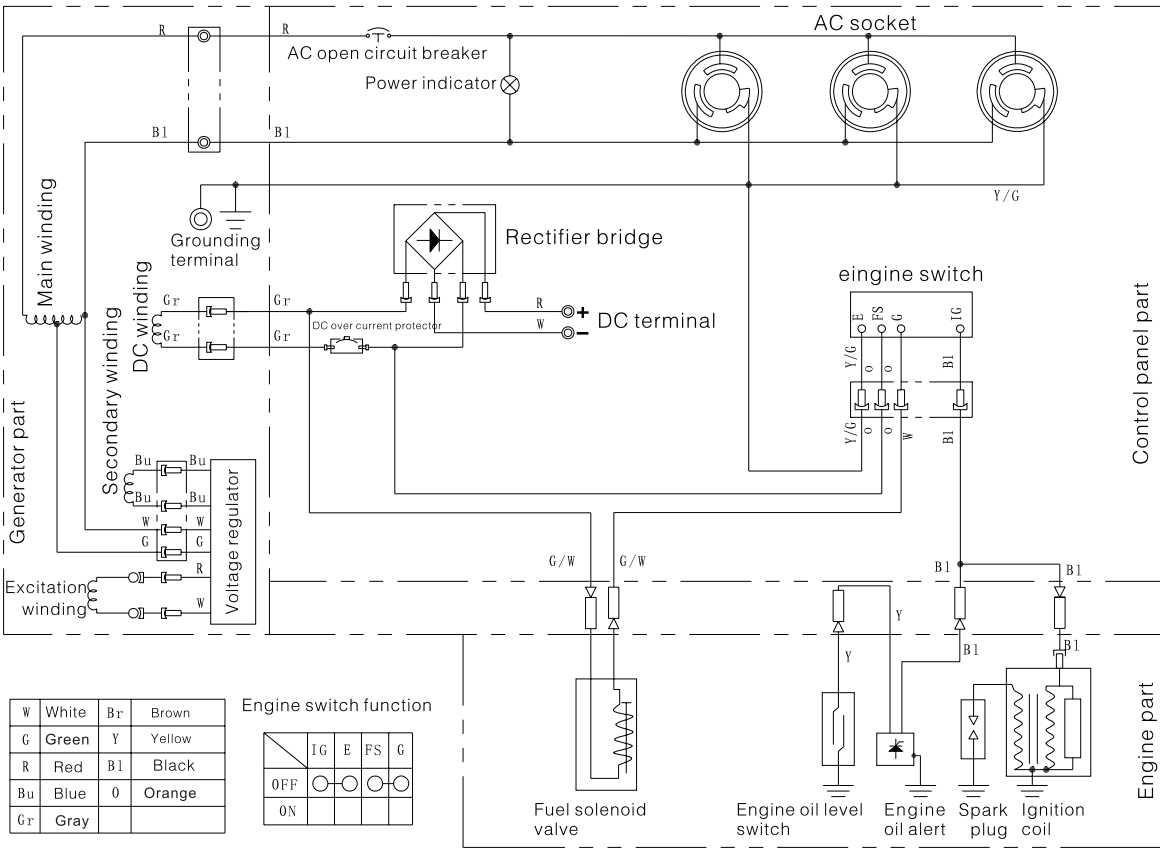

● Electrical schematic diagram 4
(applicable to 5000D-A~8000D-A)

