



General power products

Gasoline Engine

LC178F(D) • D350F(D)

LC186F(D) • D440F(D)

Owner's Manual



Thank you for purchasing a Loncin product.

Keep this owner's manual handy, so you can refer to it at any time.

This owner's manual is considered a permanent part of the engine and should remain with the engine if resold.

The information and specifications included in this publication were in effect at the time of approval for printing.

Only the D Type is equipped for both electric and manual starting.

READ THIS OWNER'S MANUAL CAREFULLY. Pay special attention to these symbols and any instructions that follow:

⚠ DANGER Indicates serious injury or death will result if instructions are not followed.

⚠ WARNING Indicates a strong possibility that serious injury or death could result if instructions are not followed.

⚠ CAUTION Indicates a possibility that minor injury or an result if instructions are not followed.

NOTICE Indicates that equipment or property damage can result if instructions are not followed.

NOTE: Gives helpful information.

If a problem should arise, or if you have any questions about your engine, consult your engine dealer.

CONTENTS

1. Engine Safety.....	4
2. Specifications.....	5
3. Name Of Parts.....	6
4. Installation.....	7
5. Operation.....	8
6. Periodic Checks And Maintenance.....	15
7. Long Term Storage.....	19
8. Performance Curves.....	20
9. Troubleshooting.....	21
10. Overall Dimensions And Installation.....	21
11. Bolt Torque Specifications.....	24

1. Engine Safety

The engines are designed to give safe and dependable service if operated according to instructions. Read and understand this owner's manual before operating the engine. Failure to do so could result in personal injury or equipment damage.

Preventing Fires

⚠ DANGER



- Never add fuel to the fuel tank while the engine is running.
- Wipe away all fuel spills with a clean cloth.
- keep the engine at least 3 feet (1 meter) away from building walls and other equipment during operation. Do not place flammable objects close to the engine.

Carbon Monoxide Hazard

⚠ WARNING



- Exhaust gas contains poisonous carbon monoxide. Avoid inhalation of exhaust gas.
- Never run the engine in a closed garage or confined area.

Preventing Burns

NOTICE



- The muffler becomes very hot during operation and remains hot for a while after stopping the engine. Be careful not to touch the muffler while it is hot. Let the engine cool before storing it indoors.

Preventing Engulfment

⚠ WARNING



- Keep away from rotating parts while the engine is running.
- When the engine is coupled with a machine ,be sure to provide covers for the belt, coupling and other dangerous parts.

2. Specifications

Model	LC178F(D) D350F(D)	LC186F(D) D440F(D)
Type	Single cylinder, vertical cylinder, 4stroke, forced cooling , direct injection	
Bore × Stroke (mm)	Ø78x73	Ø86x76
Displacement (L)	0.349	0.441
Compression ratio	21	
Rated power (kW/rpm)	4.9/3600	6.8 /3600
PTO shaft rotation	Anti-clockwise(from PTO side)	
Fuel tank capacity (L)	3.7	4.7
Lube oil capacity (L)	1.1	1.6
Starting system	Recoil start (LC178F LC186F) Electric start+ Recoil start (LC178FD LC186FD)	
Lubrication system	Forced lubrication	
Valve Clearance (mm)	Input valve: 0.10~0.15 Output valve: 0.15~0.20	
Fuel supply advance angle (°)	18±1	
Battery capability	12V36Ah	
Dimension	390×430×460	399×475×500
Net weight (kg)	With electric start ≤44 Without electric start ≤39	With electric start ≤51 Without electric start ≤47

The power rating of the engine indicated in this document is the net power output tested on a production engine for the engine model and measured in accordance with SAE J1349 at 3,600 rpm (Net Power). Mass production engines may vary from this value.

Actual power output for the engine installed in the final machine will vary depending on numerous factors, including the operating speed of the engine in application, environmental conditions, maintenance, and other variables.

3. Name Of Parts

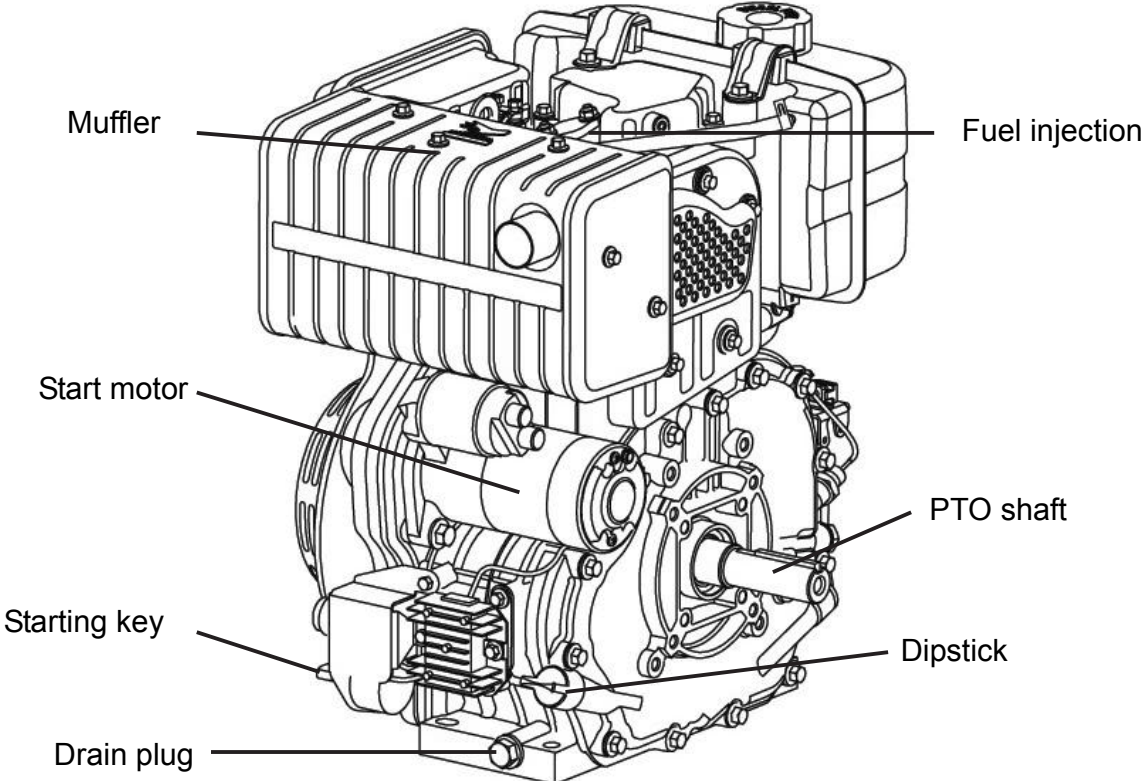
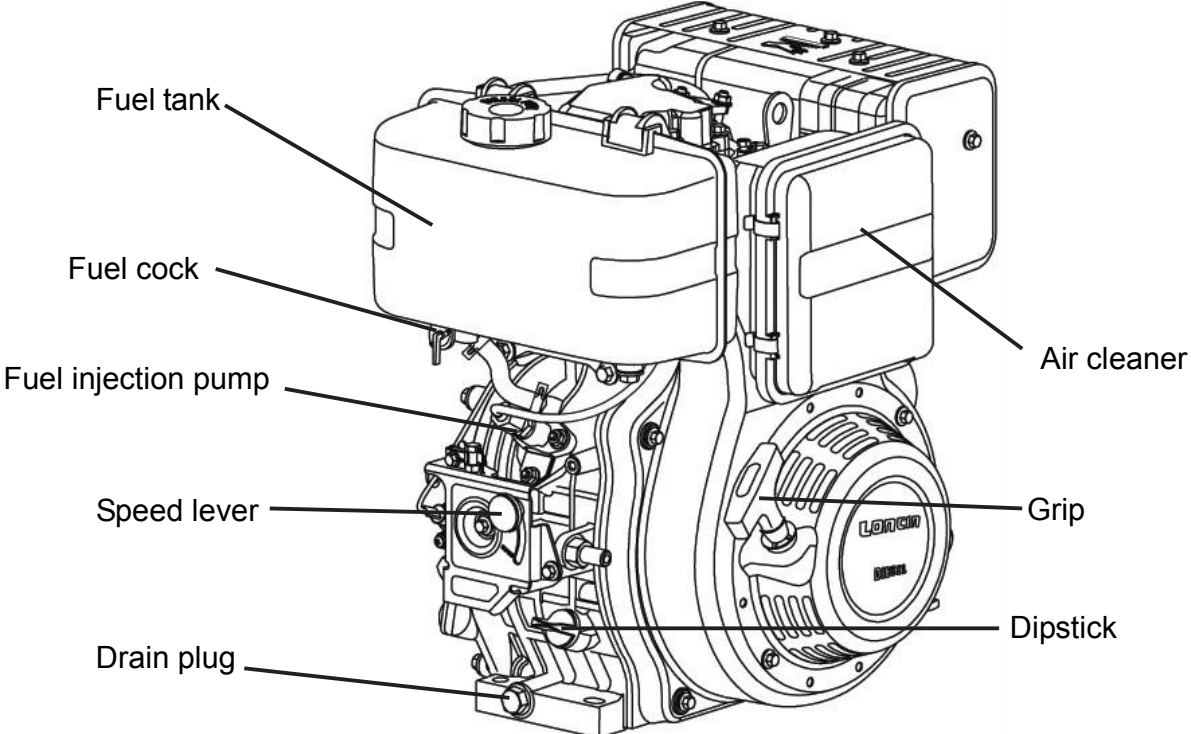

4. Installation

- Use an engine mount which is strong enough to prevent misalignment and play during engine operation.
- Ensure accurate centering for coupling with the output shaft.
- For belt driving, select a pulley which is a suitable size for the engine and which matches the revolution speed and pulley size of the driven machinery. The proper pulley size for the engine can be obtained by the following formula:

$$\text{Engine's pulley Dia.} = \frac{\text{Driven machinery pulley dia.} \times \text{Driven machinery revolution speed}}{\text{Engine's service speed}}$$

⚠ CAUTION Too much tightness overloads the engine at starting and stretches the belt, making it prone to damage. The output shaft may also be broken, and other accidents could occur. Too much looseness causes belt slippage during high output and high speed operation.

- Inclination angle

Allowable inclination(for continuous use) ($\theta < 20^\circ$)

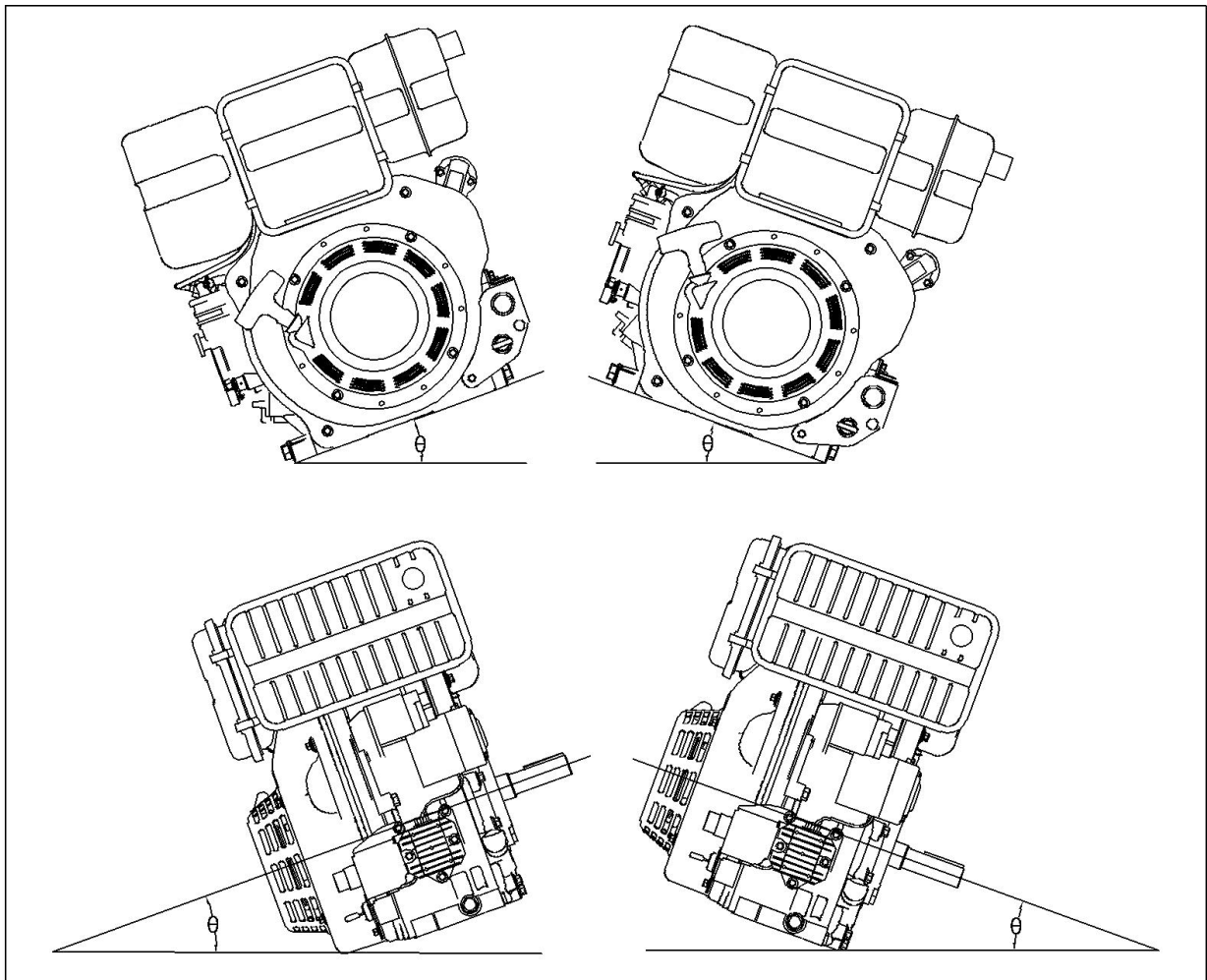

5. Operation

(1) . Preparations For Starting

1). Check The General Condition Of The Engine

- Look around and underneath the engine for signs of oil or fuel leaks.
- Look for signs of damage.
- Check that all shields and covers are in place, and all nuts, bolts, and screws are tightened.

2). Engine Oil Level Check

NOTICE

Check the engine oil level with the engine stopped and in a level position.

- Remove the filler cap/dipstick and wipe it clean.
- Insert and remove the dipstick without screwing it into the filler neck. Check the oil level shown on the dipstick.
- If the oil level is low, fill to the edge of the oil filler hole with the recommended oil.
- Screw in the dipstick securely.

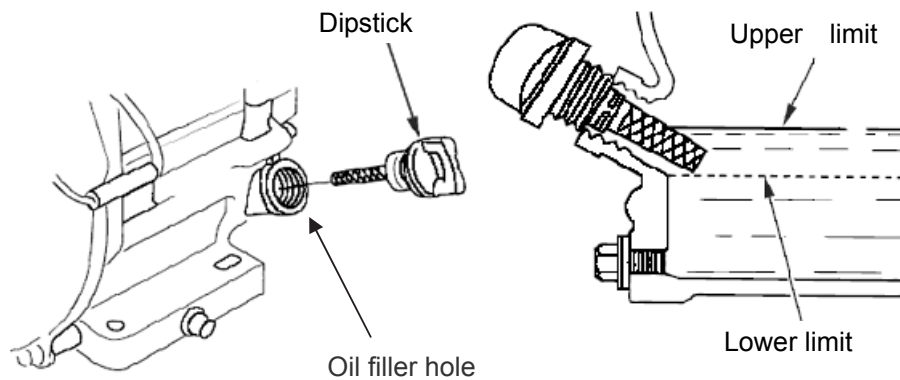

Service categories: API service categories CD or higher

SAE 15W-40 is recommended for general, all-temperature use. Other viscosities shown in the chart may be used when the ambient temperature in your area is within the indicated range.

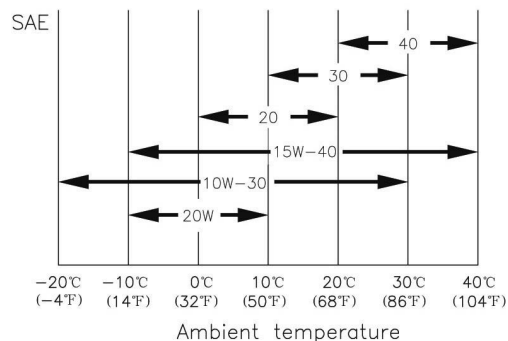

3). Refueling

With the engine stopped, remove the fuel tank cap and check the fuel level. Refill the tank if the fuel level is low.

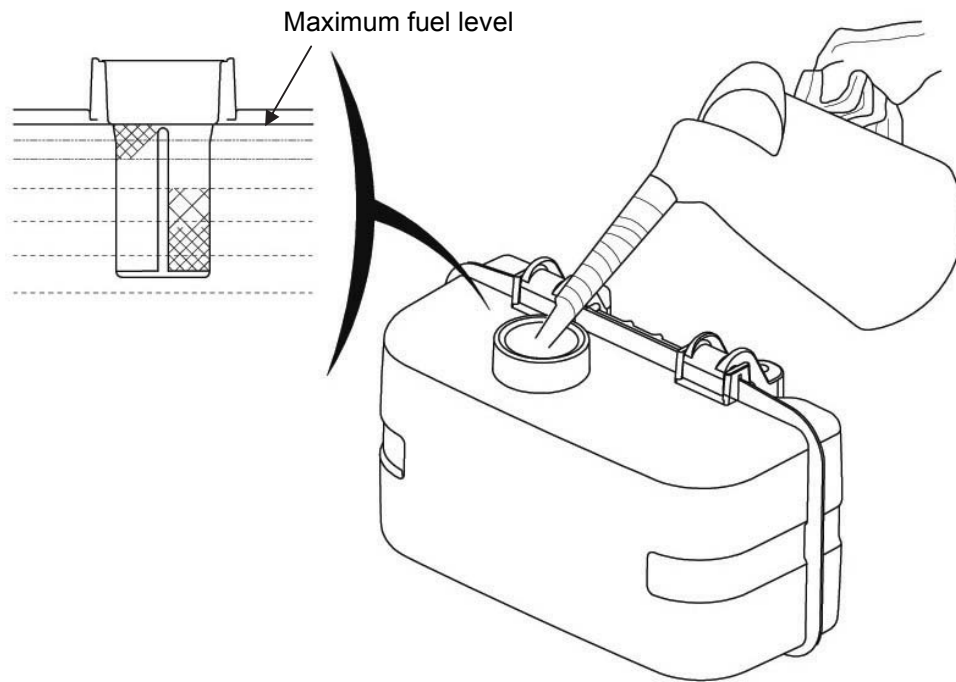

⚠ DANGER

Only fill the fuel tank with diesel fuel. Filling the fuel tank with gasoline may result in a fire

(2) . Starting The Engine

1).Recoil Starting

- ① Move the fuel valve lever to the ON position.

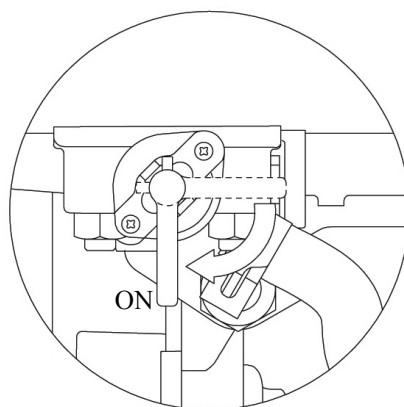

- ② Set the engine speed lever at " START " Position, turn the engine speed control knob to right.

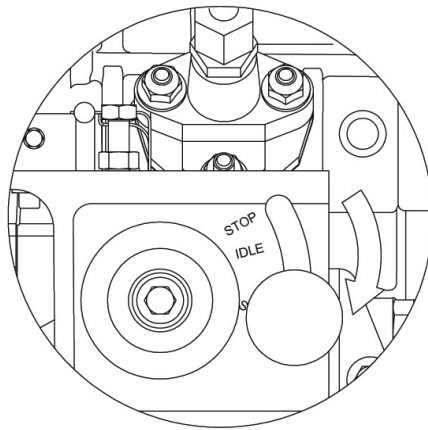

- ③ Pull the starter grip lightly until you feel resistance. **ATTENTION : slowly**
- ④ Slowly return the starter grip to the initial position. **ATTENTION : return the grip**

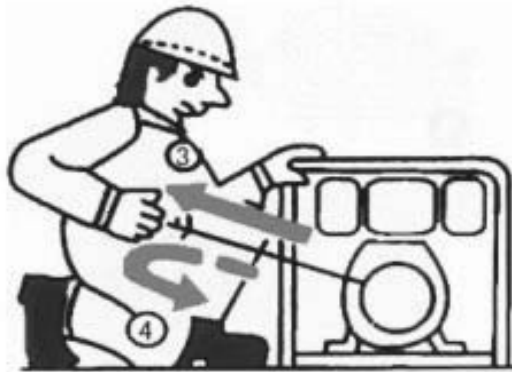

- ⑤ Hold the starting handle firmly ,pull the starter grip all the way out with a strong and even motion, then return it to slowly. Use two hands if necessary. **ATTENTION: strong and quickly pull.**

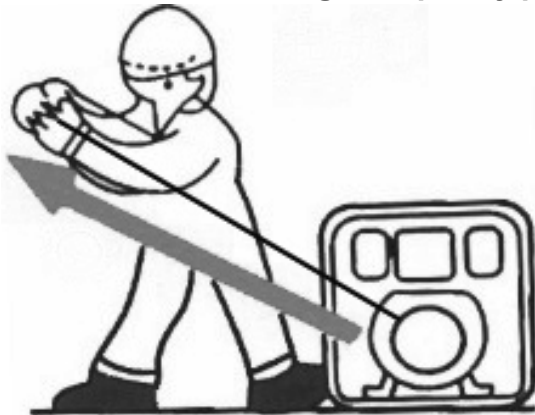

- ⑥ If the engine doesn't start, try again from ③.

NOTICE

**Do not allow the starter to snap back against the engine.
Return it gently to prevent damage to the starter.**

2). Electric Starting

- ① Move the fuel valve lever to the ON position.
- ② Set the engine speed lever at " START " Position.
- ③ Turn the starting key to "START".
- ④ Remove your hand from the key as soon as the engine starts.

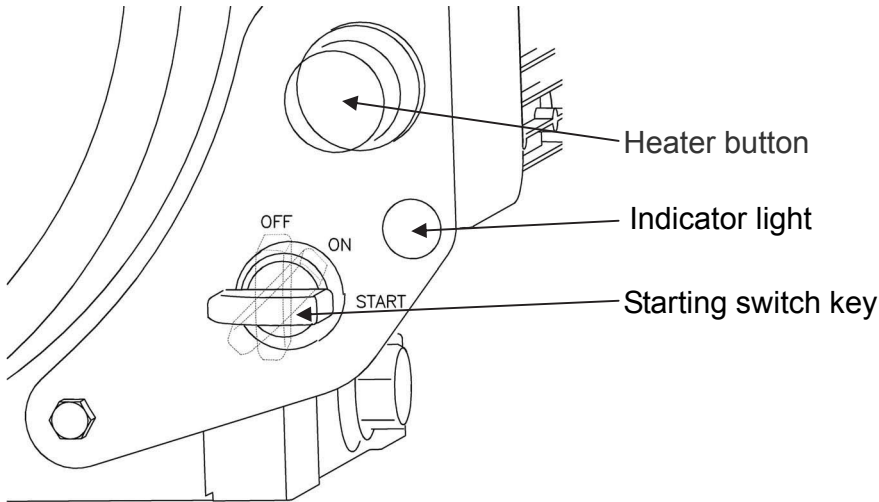

- ⑦ If the starting motor doesn't start after 10 seconds, wait a while (for about 15 seconds) before attempting to start again.

When the engine is difficult to start in cold weather, Press the heater button for about 10-20 seconds and then release, you can easily start the engine.

⚠ CAUTION

- If the starting motor is turned for too long, the battery will go flat and the motor will seize up.

When the engine is stopped , the starting key switch is turned clockwise to the "ON" position, then the oil pressure Indicator light is on.

When the engine is running , the start switch key stop in the "ON" position, the oil pressure indicator light goes out, if the light stays lit, you should stop to check the oil level.

Wiring Diagram

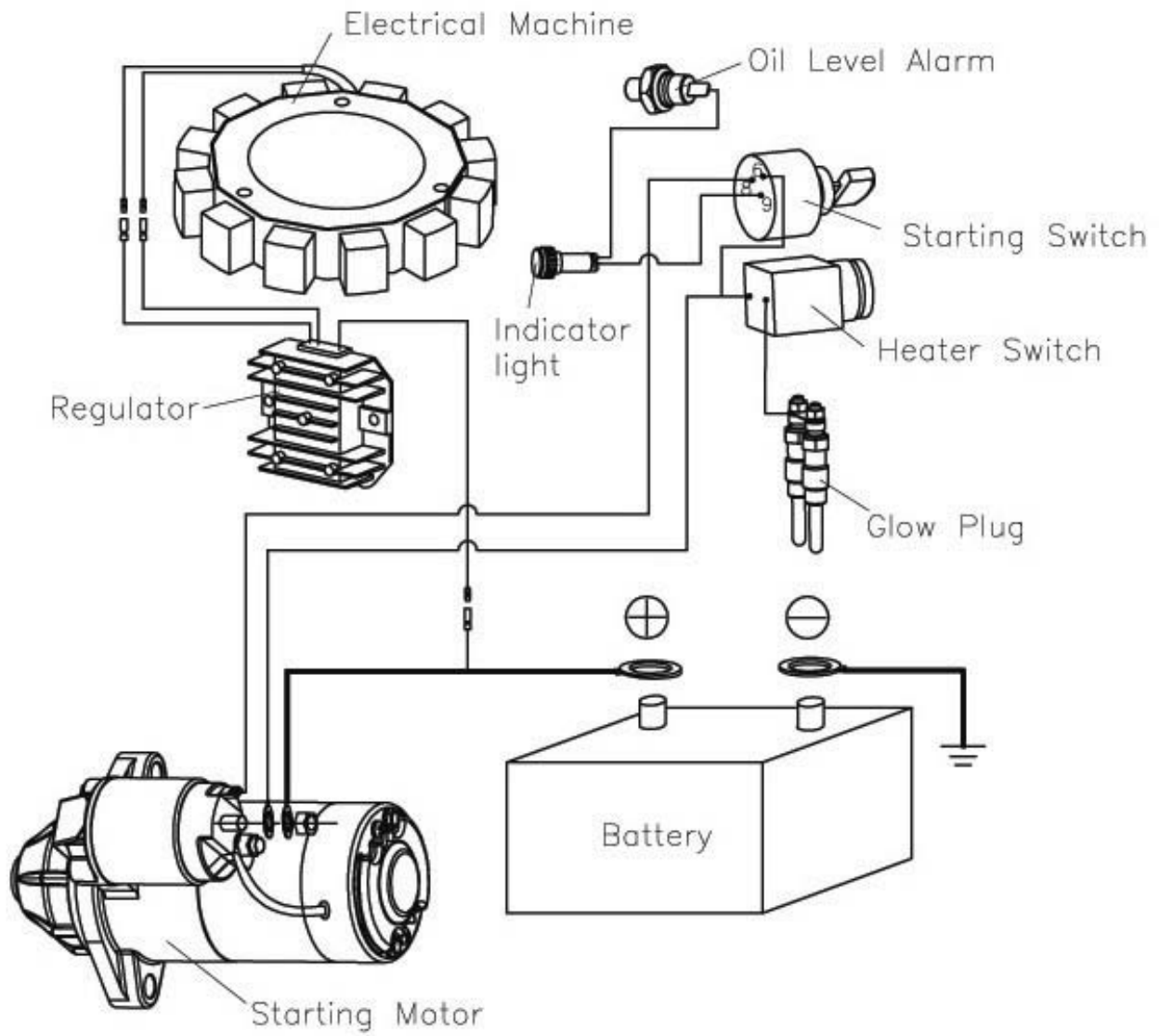

(3) . Operating your engine

- 1) Warm up the engine without load for about 3 minutes.
- 2) Turn the engine speed lever to the desired speed position and fasten the thumb nut.

NOTICE

- 1) During the initial 20 hours is new engine break in, avoid prolonged operation at minimum or maximum engine speeds and loads. Check oil after the engine break-in period.
- 2) If you notice any abnormal sound , vibrato or running rough, The color of the exhaust gas always blueness or white, stop the engine and consult your nearest dealer.

⚠ CAUTION

- 1) Never run the engine if the ambient temperature is above +40°C or below -10°C.
- 2) At high altitudes the engine will lose power, run rough ,and produce exhaust gases that exceed the design specifications.

⚠ WARNING

- 1) If the engine has been running, the muffler will be very hot , Be careful not to touch the muffler.
- 2) Never refill the fuel while the engine is running.

(4) . Stopping your engine

- 1) Before stopping the engine, move the engine speed lever to low speed, and run the engine for about 3 minutes with no load.
- 2) Turn the engine speed control knob to the left, Return the engine speed lever to the "STOP" position.

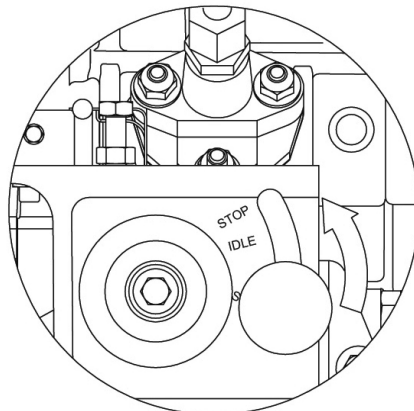

- 3) In electric-start models, return the starter key to the “OFF” position.
- 4) Set the fuel cock lever to “OFF” (closed) position.

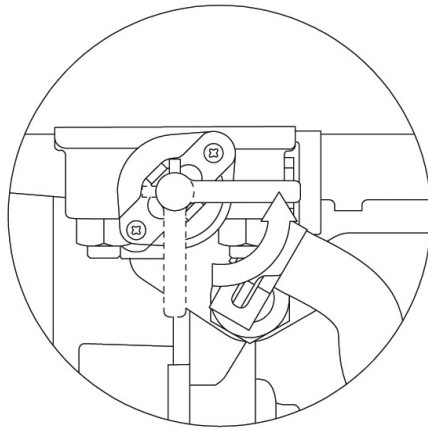

- 5) Pull the recoil starter slowly, stop when it feels tight.

NOTICE

When stopping the engine, reduce the load slowly. Don't stop the engine suddenly since this may cause the temperature to rise abnormally.

6. Periodic checks and maintenance

Periodic checks and maintenance are very important for keeping the engine in good condition and durable. The chart below indicates which checks to make and when to make them.

The mark (▲) indicates that special tools and skills are required.

Item \ Operation hours	Daily	20 hours	100 hours	200 hours	500 hours	1000hours
Check and tighten bolt and nuts	○ Before operation					
Check and resupply engine oil	○ Before operation					
Replace engine oil		○ 1st time	○ 2nd & after			
Clean oil filter replace if damaged		○ 1st time	○ 2nd & after			
Check oil leakage	○ Before & after operation					
Clean or replace air cleaner element	Service more frequently when used in dusty areas			○		
Drain and clean the fuel tank				○		
Check and replace fuel filter						○
Check fuel injection nozzle						▲
Check fuel injection pump						▲
Check fuel piping replace if damaged					○	
Adjust intake/exhaust valves head clearance		▲ 1st time			▲	
Check and lap intake/exhaust valves seat						▲
Replace piston rings						▲
Check battery liquid	○ Before operation					

(1).Engine oil change

Drain the used oil while the engine is warm. Warm oil drains quickly and completely.

- 1) Place a suitable container below the engine to catch the used oil, and then remove the filler cap/dipstick and the drain bolt.
- 2) Allow the used oil to drain completely, and then reinstall the drain bolt, and tighten it securely.
- 3) With the engine in a level position, fill to the outer edge of the oil filler hole with the recommended oil.
 - Please dispose of used motor oil in a manner that is compatible with the environment. We suggest you take used oil in a sealed container to your local recycling center or service station for reclamation. Do not throw it in the trash; pour it on the ground; or down a drain.

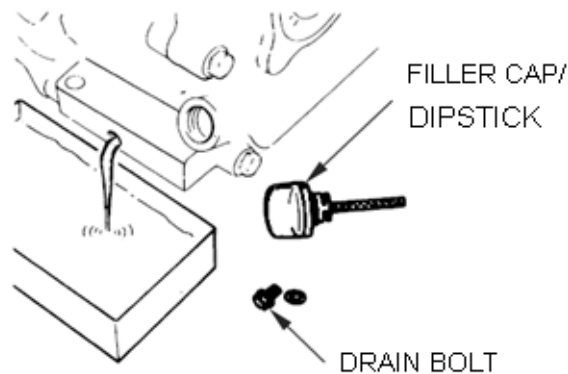

(2).Clean/inspect engine oil filter

Remove the oil filter, clean oil filter or replace if damaged, and then install the oil filter.

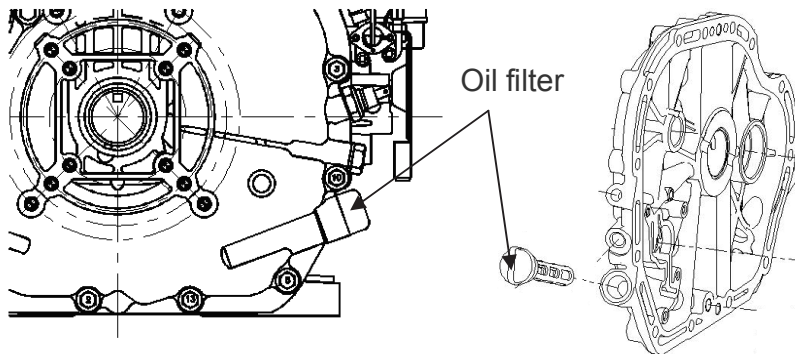

(3). Air filter inspection

A dirty air filter will restrict air flow to the firebox, reducing engine performance. Lower the clamp, remove the air cleaner cover and inspect the filter.

NOTICE

Operating the engine without an air filter, or with a damaged air filter, will allow dirt to enter the engine, causing rapid engine wear.

1) Dry-type air cleaner

Unsnap the air cleaner cover clips, remove the air cleaner cover, Tap the filter element several times on a hard surface to remove dirt, or blow compressed air [not exceeding 30 psi (207 kPa)] through the filter element from the inside, replace dirty filter element if damaged.

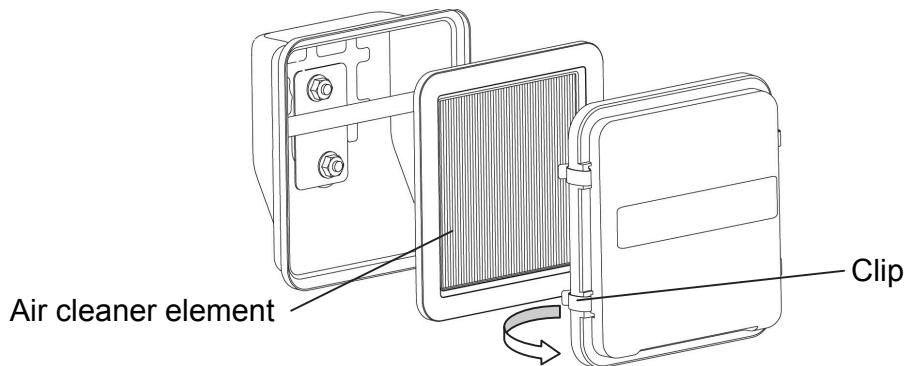

2) Oil bath type air cleaner

Check oil level before operation and clean air cleaner elements every 50 hours.

- ① Stop the engine, let it sit for 10 minutes. Lower the clips, remove the oil pan and the air cleaner elements.
- ② Clean the oil pan.
- ③ Wash the air cleaner elements with diesel fuel, blow out excess fuel with compressed air.
- ④ Make sure that the sealing ring are in a good condition and replace them if they are damaged.
- ⑧ Fill engine oil pan of air cleaner to marked oil level.
- ⑨ Replace the air cleaner elements and oil pan.

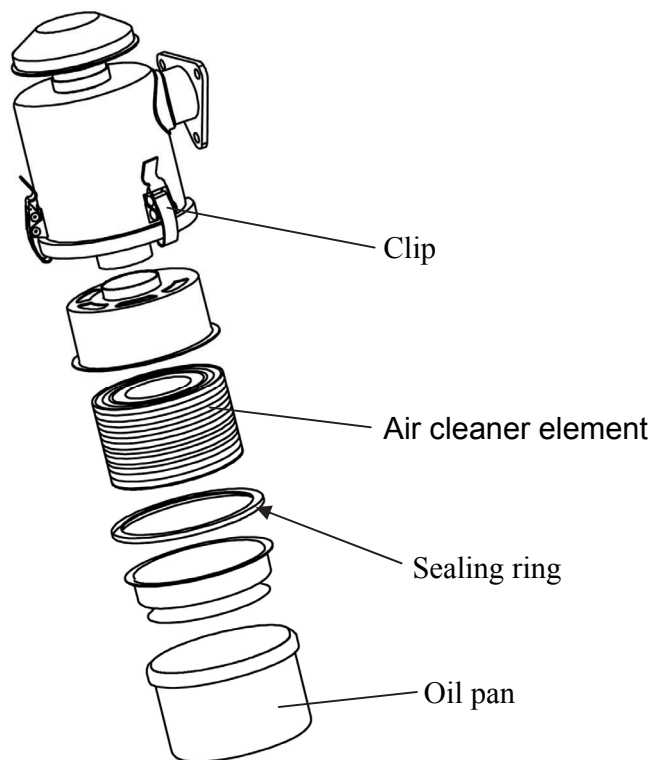

(4) Clean or replace inlet fuel screen and outlet fuel filter

1) Remove the fuel cap, lift out the inlet fuel screen, clean the inlet fuel screen or replace if damaged. Replace the inlet fuel screen and hand tighten the fuel cap.

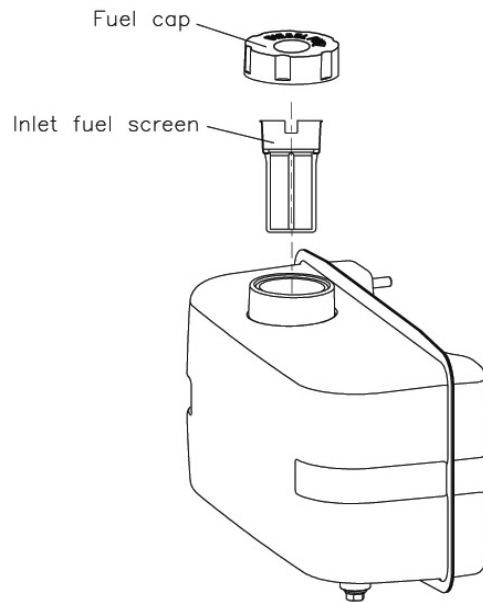

2) Remove the fuel cap and the inlet fuel screen, the tank drain plug and the gasket to drain the fuel. Loosen the nuts and remove the cock, pull out the fuel filter. Install a new fuel filter and seals through the fuel tank filler port and seat in the fuel tank. Fasten the assembly to the tank using the fuel cock nuts. Tighten the fuel tank drain plug and gasket.

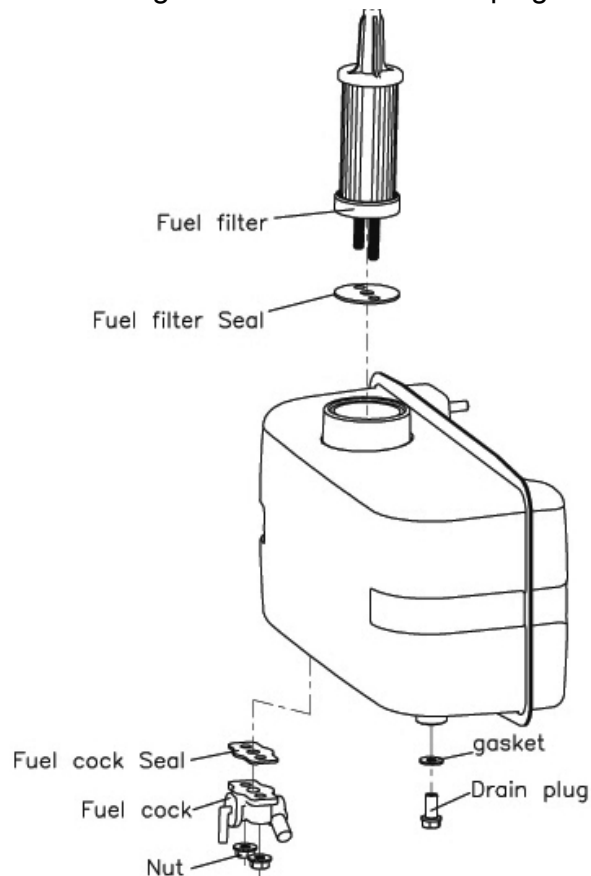

(5) Check the battery

Check the electrolyte level to be sure that it is between the marks on the case. If the level is below the lower mark, remove the caps and add distilled water to bring the electrolyte level to the upper mark. The cells should be equally full.

NOTICE

Do not reverse polarity. Serious damage to the engine and/or battery may occur.

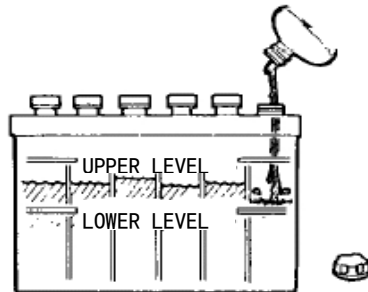

7. Long term storage

If store your engine for long periods, make the following preparations.

- 1) Operate the engine for about 5 minutes and then stop.
- 2) Stop the engine, drain the engine oil while the engine is still warm and fill with new oil.
- 3) Pull the recoil starter slowly, Stop when it feels tight. This closes the intake and exhaust valves (in compression position) and helps prevent rust from forming.
- 4) Wipe the oil and dirt from the engine and store in a dry place.

8. Performance Curves

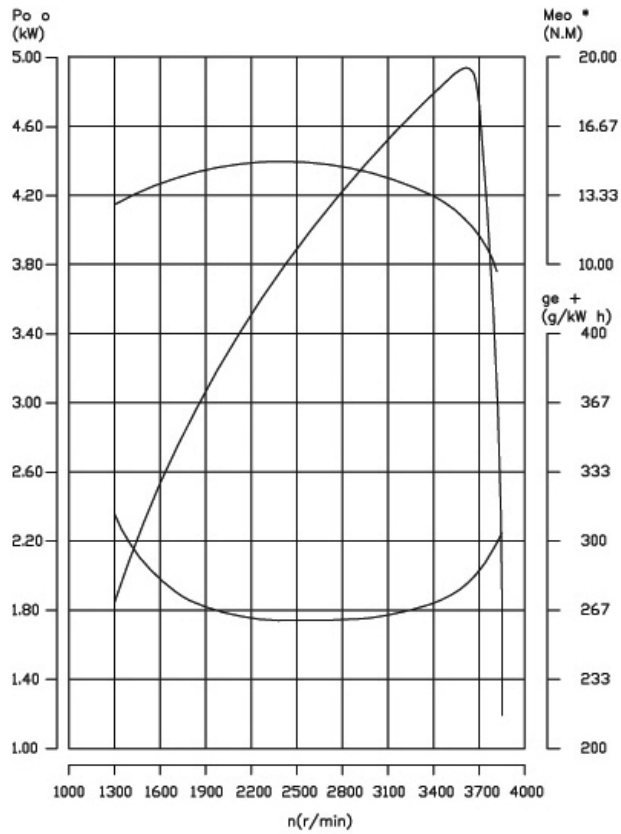

(LC178F D350F)

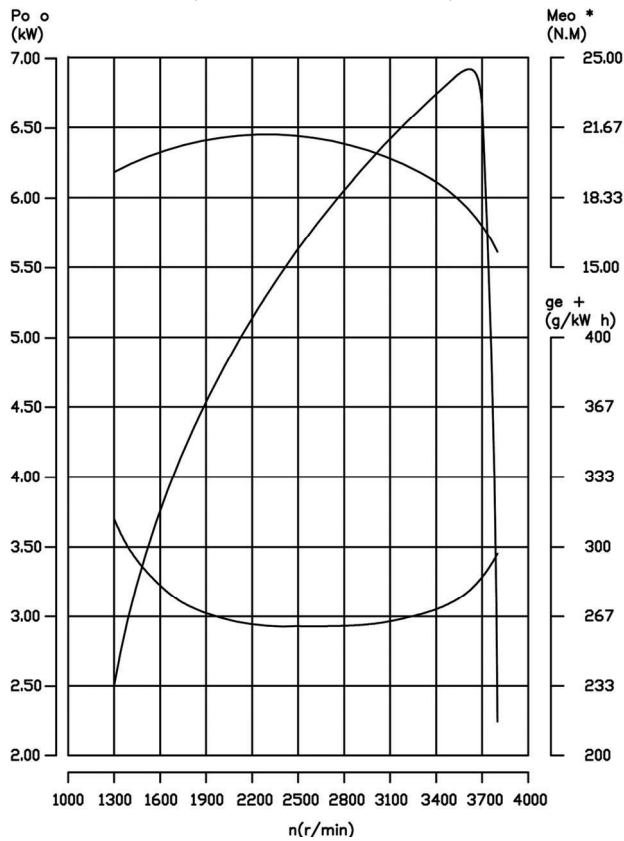

(LC186F D440F)

9. Troubleshooting

1) Engine Does Not Start

Possible Cause	Correction
No diesel fuel	Refuel fuel system
Improper diesel fuel	Refuel with recommended diesel fuel
Clogged fuel filter	Replace fuel filter
Faulty spraying of fuel injection	Purge or replace fuel injection
Starter motor does not operate or rotates too slowly (engine can be turned manually)	Check electrolyte ,recharge Clean terminals ,retighten

2) Engine Lacks Power

Possible Cause	Correction
Fuel system clogged	Purge or replace fuel vitta ,filter or cock
Faulty spraying of fuel injection	Purge or replace
Faulty of fuel injection pump	Purge or replace
Clogged air cleaner element	Clean or replace filter element.

3) Black exhaust smoke

Possible Cause	Correction
Engine overloaded	Reduce load
Improper diesel fuel	Replace with recommended diesel fuel
Faulty spraying of fuel injection	Purge or replace
Clogged air cleaner element	Clean or replace filter element.

10. Overall Dimensions And Installation:

LC178F(D)

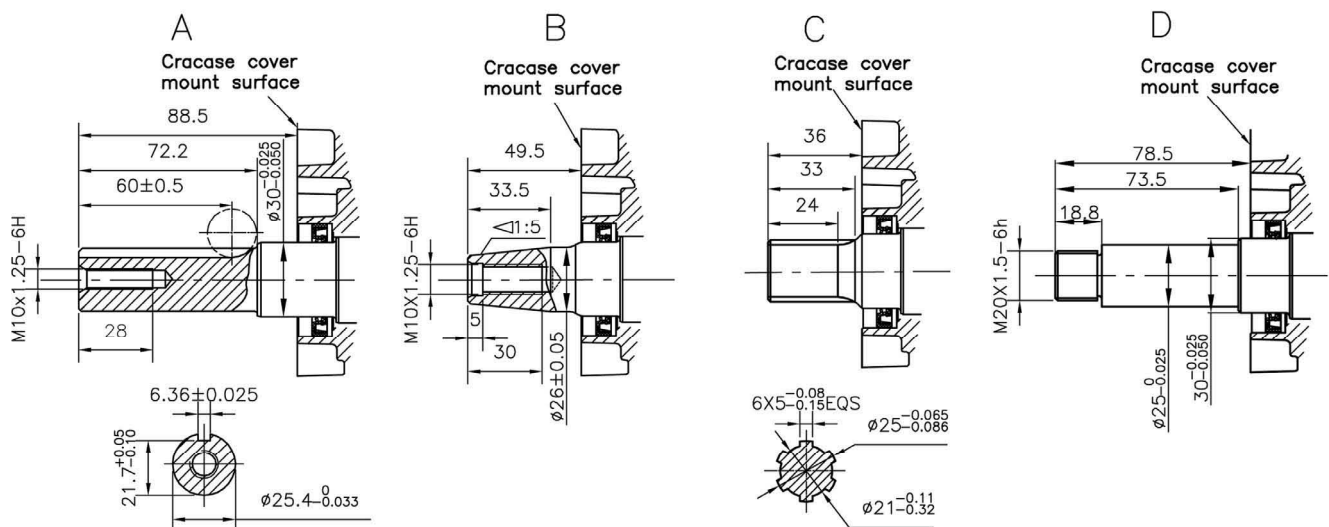

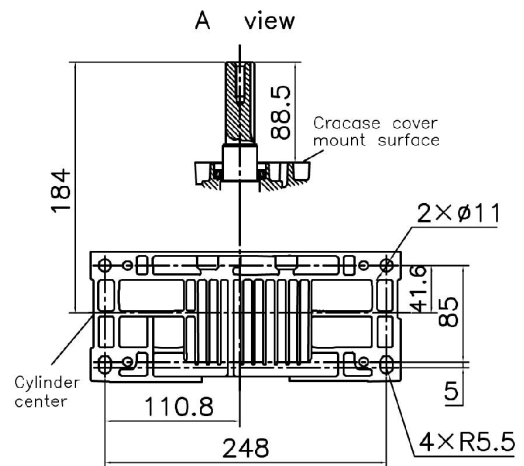
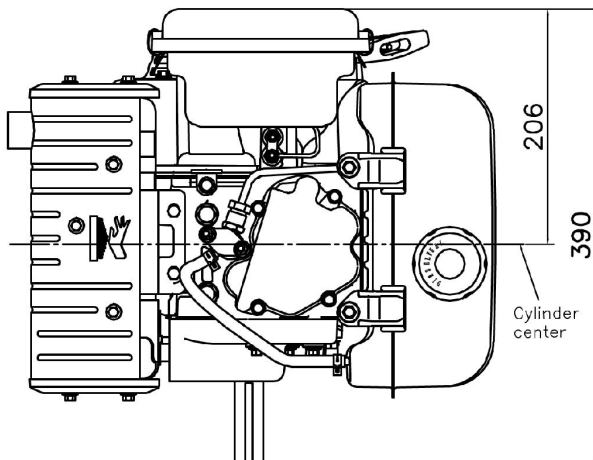
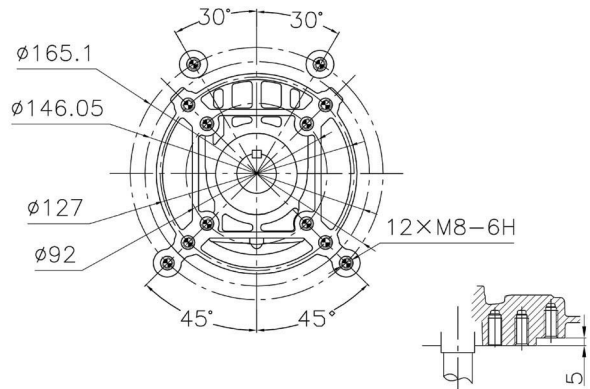
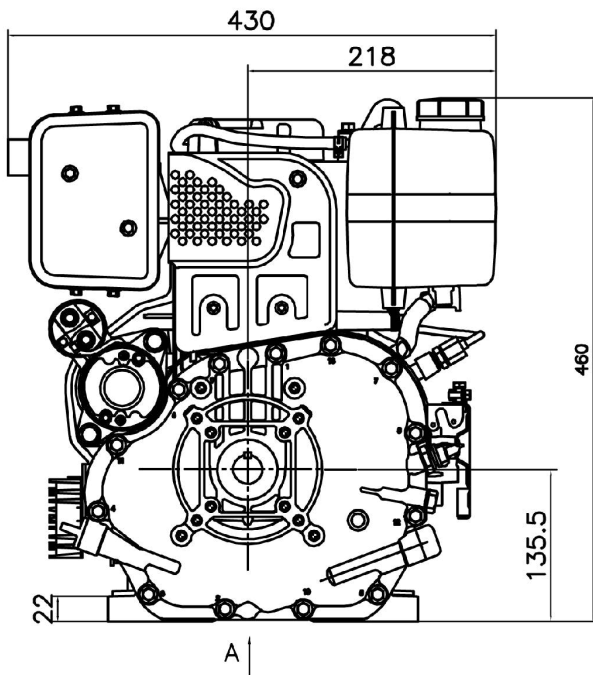
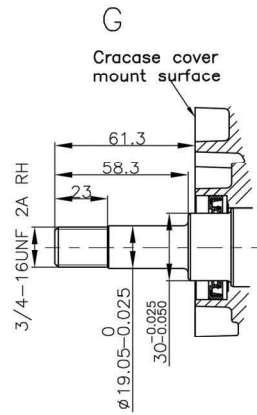
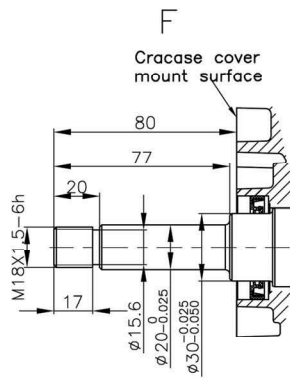
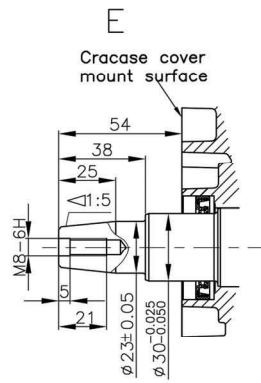

LC186F(D)

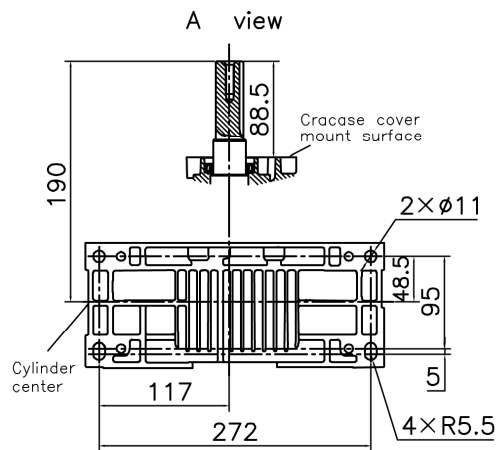
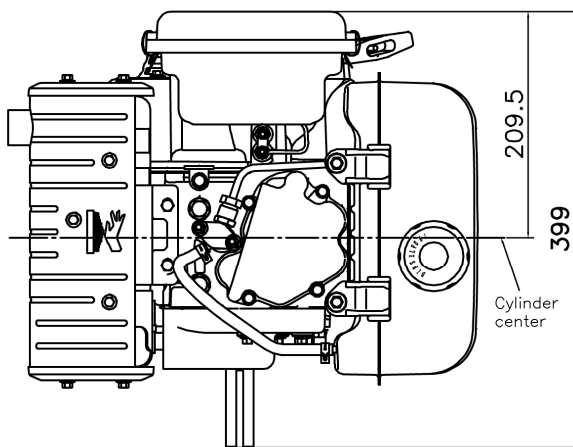
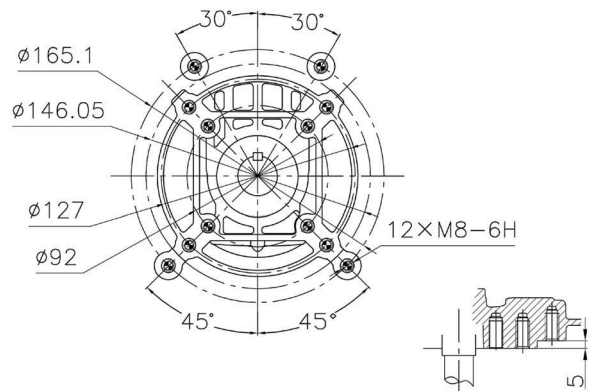
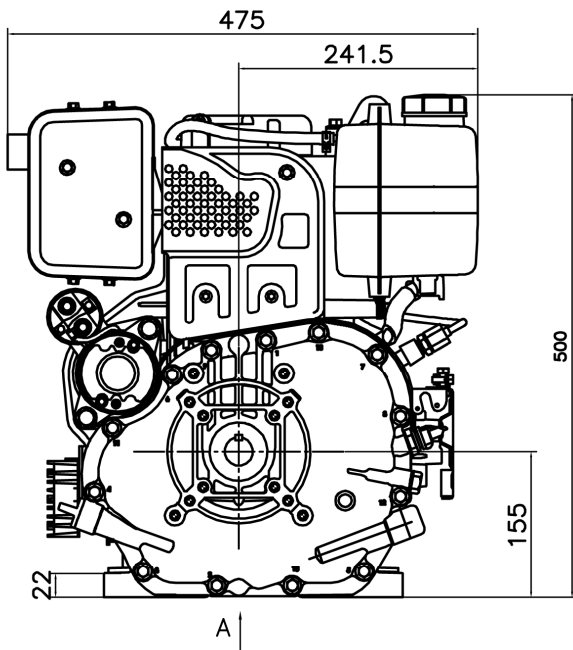
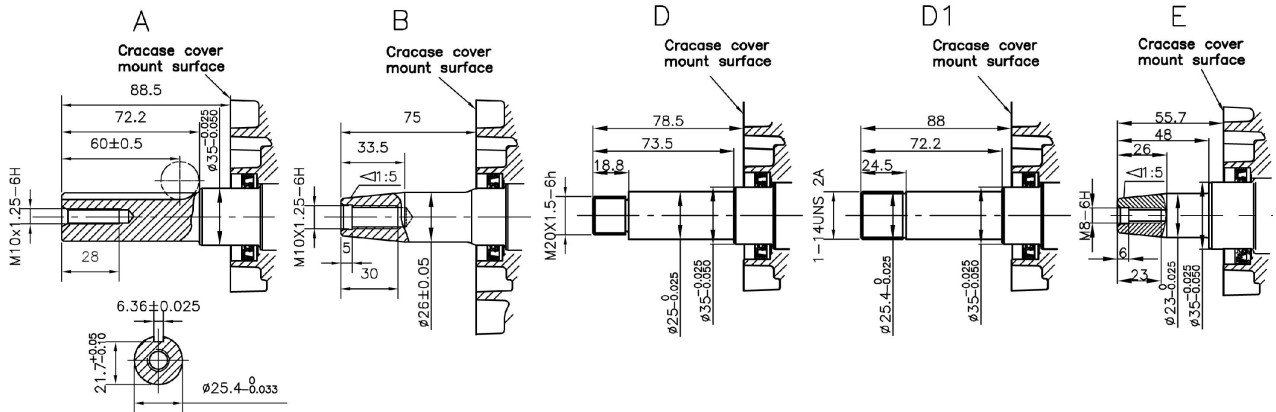

11. Bolt Torque Specifications

NO.	Item	Remark	Tightening Torque (N.m)
1	Rocker Arm Studs	M8 class 8.8	30±2 Nm
2	Rocker Arm Lock Nut	M6x0.75 class 8.8	10±1Nm
3	Connecting Rod Bolts	M7x38.5 class 10.9	30±2Nm
4	Flywheel Bolt	M12x40 class 8.8	80±2Nm
5	End Plate Bolts	M8x35 class 8.8	22±2 Nm
6	Muffler Nuts	M8 class 8.8	25±2 Nm
7	Oil Drain Plug	M16x1.5 class 8.8	30±5Nm
8	Rocker Cover Bolts	M6x25 class 8.8	10±1Nm
9	Cylinder Head Bolts	M10x90 class 10.9	Cross wise sequence Step 1 28~32Nm Step 2 58~62Nm
10	Fuel Injection Pump Nuts	M6 class 8.8	11±1Nm
11	Fuel Injector Nuts	M6 class 8.8	8±1Nm
12	Shrouds, muffler	M6x25 class 8.8	10±1Nm
13	Fan Cover	M6x30 class 8.8	10±1Nm
14	Air box	M8 class 8.8	25±2Nm
15	HP Fuel Line Union, Pump	M12x1.5	35±2Nm
16	HP Fuel Line Union, Injector	M14x1.5	35±2Nm

Unspecified bolts and nuts listed above, refer to the table of standard torque values.