

FLOWFIT REDUCTION GEARBOXES KR700 SERIES GROUP 3 PUMP - 20KW

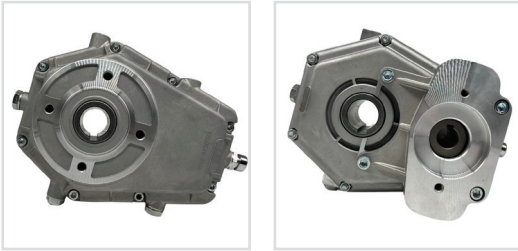

KR70016-2AW

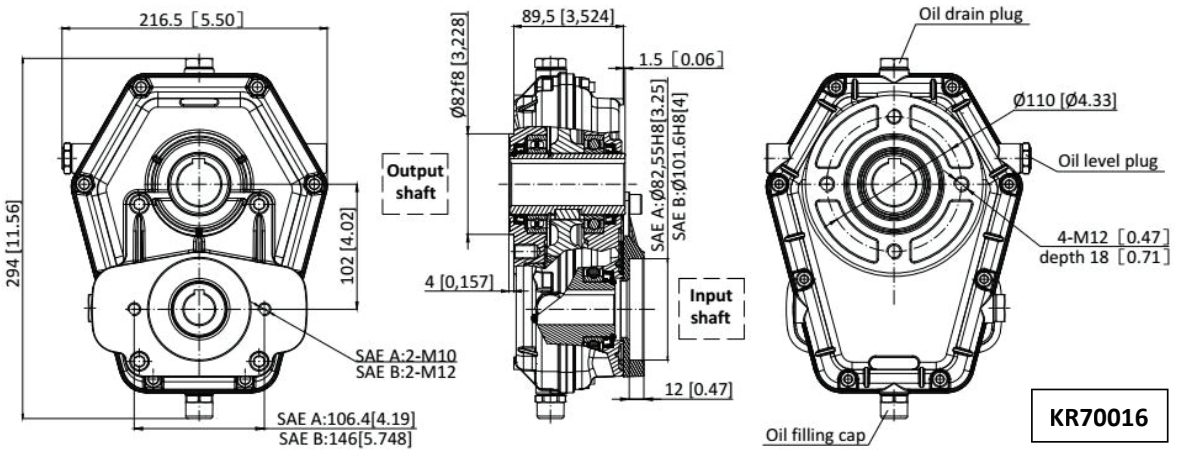

KR70016

M1 MAXIMUM CONTINUOUS TORQUE OF THE SPEED INCREASER (INPUT SIDE daNm)	M2 MAXIMUM TORQUE OF THE SPEED INCREASER (OUTPUT SIDE daNm)	N1 OUTPUT SPEED AFTER REDUCTION RPM	N2 INPUT SPEED BEFORE REDUCTION RPM	I RATIO OF SPEED REDUCTION ON N2 = N1	MAX TRANSMITTABLE POWER KW	WEIGHT KG
48	32	200	300	1,5	20	8,5
48,5	24,2	200	400	2	20	8,5
52	20,8	200	500	2,5	20	8,5
57	19	200	600	3	20	8,5
53	15,1	200	700	3,5	20	8,5
52,5	13,8	200	760	3,8	20	8,5

How to order:

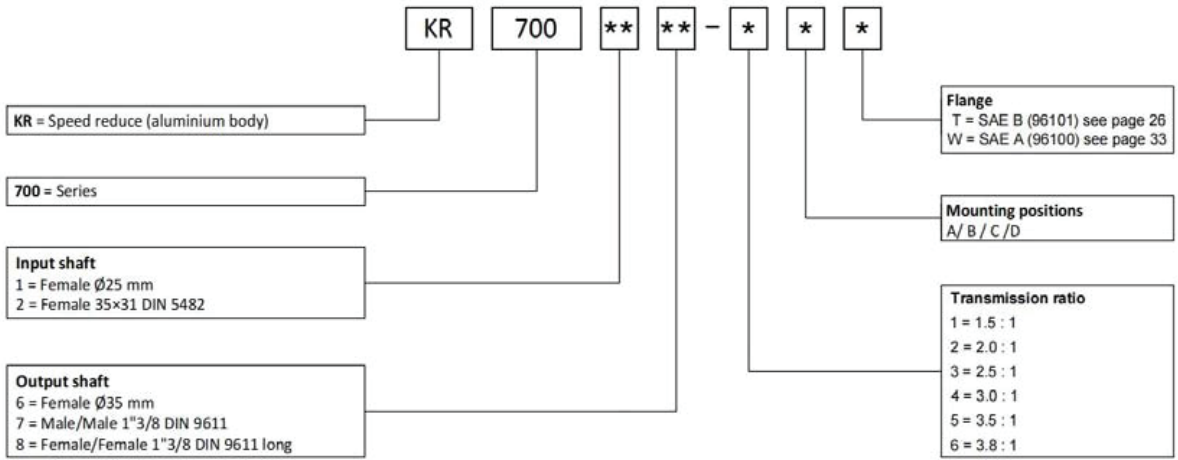

For example: KR70016-1AT

PART NO.	DESCRIPTION OF REDUCTION GEARBOX	MOUNT & INPUT SHAFT	RATIO	OUTPUT
KR70016-2AW	REDUCTION GEARBOX 20KW GR.3	SAE A MOUNT-25MM KEYED SHAFT	1:2	Female Ø35 mm
KR70016-3AW	REDUCTION GEARBOX 20KW GR.3	SAE A MOUNT-25MM KEYED SHAFT	1:2,5	Female Ø35 mm
KR70016-4AW	REDUCTION GEARBOX 20KW GR.3	SAE A MOUNT-25MM KEYED SHAFT	1:3	Female Ø35 mm
KR70016-5AW	REDUCTION GEARBOX 20KW GP.3	SAE A MOUNT-25MM KEYED SHAFT	1:3,5	Female Ø35 mm
KR70016-5FW1	REDUCTION GEARBOX 20KW GP.3 - Larger style	SAE A MOUNT-25MM KEYED SHAFT	1:3,5	Female Ø35 mm
KR70016-6AW	REDUCTION GEARBOX 20KW GP.3	SAE A MOUNT-25MM KEYED SHAFT	1:3,8	Female Ø35 mm