

CAST IRON GEARBOXES

FLOWFIT PTO CAST IRON GEARBOX KMT700 SERIES GROUP 3 PUMP - 37KW CAST IRON

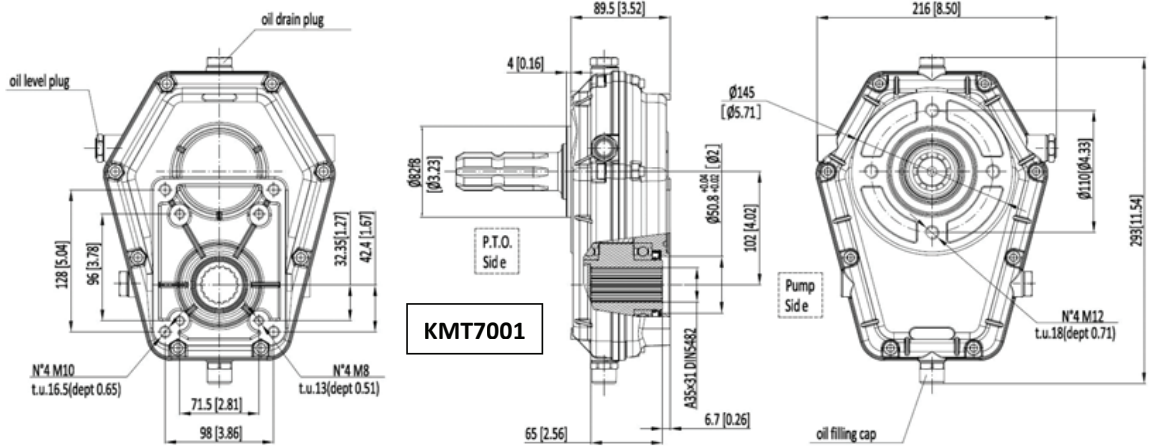

KMT7001-6A



P.T.O.

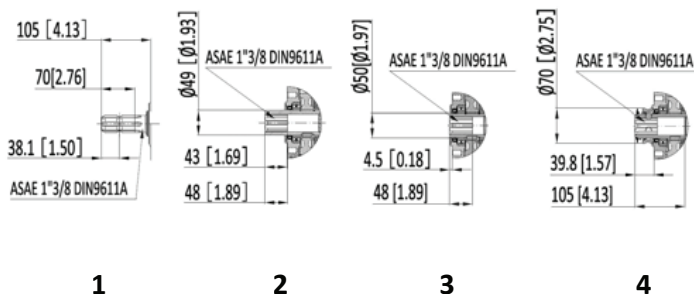

Mounting positions

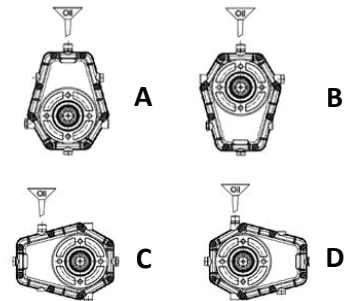

PART NO.	SHAFT	RATIO	MOUNTING POSITION
KMT7001-1A	1" Male 3/8 DIN 9611	1.1,5	A
KMT7001-2A	1" Male 3/8 DIN 9611	1.2	A
KMT7001-3A	1" Male 3/8 DIN 9611	1.3	A
KMT7001-5A*	1" Male 3/8 DIN 9611	1.3,5	A
KMT7001-6A	1" Male 3/8 DIN 9611	1.3,8	A
KMT7004-1A	1" Female 3/8 DIN 9611	1.1,5	A
KMT7004-2A	1" Female 3/8 DIN 9611	1.2	A
KMT7004-3A	1" Female 3/8 DIN 9611	1.3	A
KMT7004-5A	1" Female 3/8 DIN 9611	1.3,5	A
KMT7004-6A	1" Female 3/8 DIN 9611	1.3,8	A

How to order:

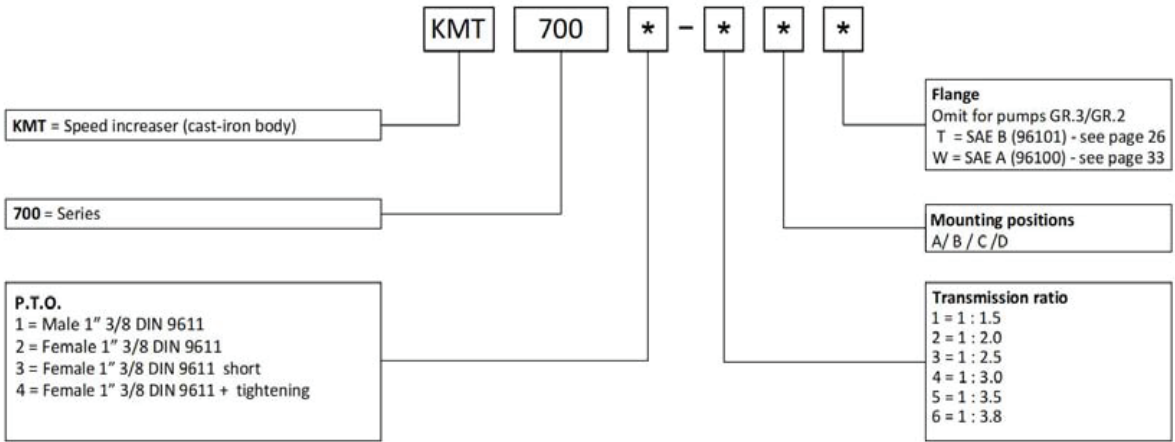

For example: KMT7001-1AT

INPUT TORQUE (Nm)	OUTPUT TORQUE (Nm)	INPUT SPEED (r/min)	TRANSMISSION RATIO	OUTPUT SPEED (r/min)	POWER (Kw)	WEIGHT (Kg)
660	440	540	1.5	810	37	16
660	330	540	2	1080	37	16
660	264	540	2.5	1350	37	16
660	220	540	3	1620	37	16
660	180	540	3.5	1836	37	16
660	166	540	3.8	2052	37	16