

## LOG SPLITTER AUTO KICK OUT VALVE

- Constructed of high tensile strength gray cast iron
- Built-in adjustable relief valve
- Hard chrome plated spool

### RECOMMENDED HYDRAULIC SYSTEM

- Maximum tank pressure: 500 PSI (35 BAR)
- Maximum operating temperature: 180°F
- Recommended system filtration: 10 micron

### STANDARD FEATURES

- Maximum LPM: 136
- Maximum operating pressure : 3,500 PSI (241 BAR)
- Spool action is spring centre/hydraulic kick-off
- Built-in relief valve preset at 1,800 PSI (124 BAR)
- Kick-off pressure is non-adjustable, preset at 800 PSI (55 BAR)
- Handle can be installed in "up" or "down" position

**EVOLUTION**



Pressure Drop

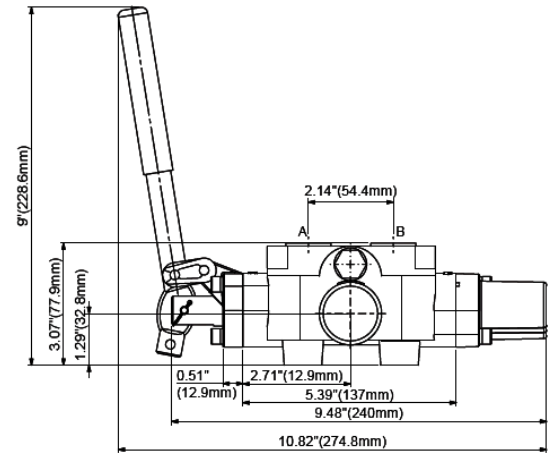
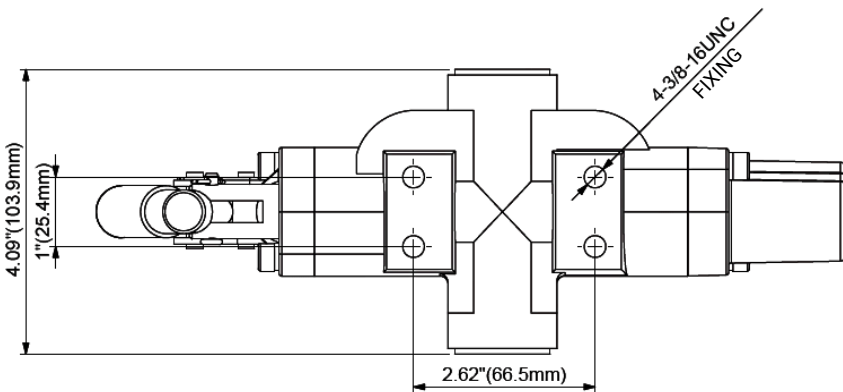
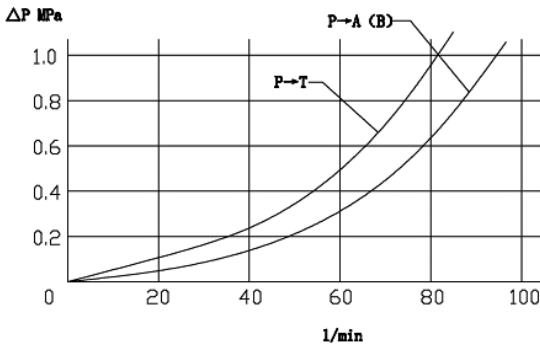

PART NUMBER	INLET/OUTLET PORTS	WORKING PORTS	MAX FLOW (LPM)	MAX PRESSURE (PSI)	RELIEF VALVE	KICK OFF PRESSURE	WEIGHT
LS305NBA42	3/4" BSP	1/2" BSP	136	3625 (230 BAR)	Adjustable, preset at 2,250 PSI (155 BAR)	Non-adjustable, preset at 800 PSI (55 BAR)	4.5Kg