

CARATTERISTICHE TECNICHE TECHNICAL FEATURES

Pressione massima Maximum pressure	350 bar (5075 psi)
Portata nominale Nominal Flow	40 l/min (7,8 gpm)
Temperatura di esercizio Operating temperature	-30 / +110 °C
Cavità Cavity	C007
Trafilamento interno Internal leakage	0,25 cm ³ /min @ 350 bar
Coppia Torque	40-45 Nm
Peso Weight	0,12 kg

SCHEMA IDRAULICO HYDRAULIC SCHEME

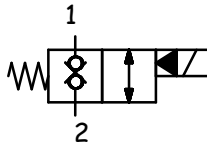

BOBINA COIL

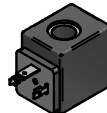

13-39
18 W

pag. 20.0

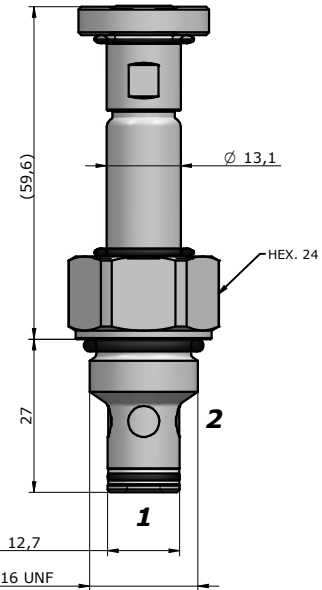

PRESTAZIONI PERFORMANCES

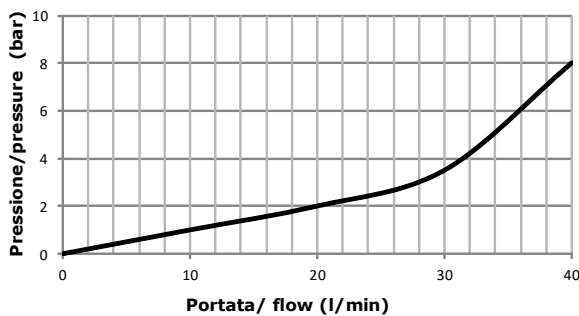

DESCRIZIONE DESCRIPTION

Quando la bobina è eccitata, l'otturatore si solleva e fa sì che da 2 a 1 e da 1 a 2 ci sia passaggio libero.
Quando la bobina è diseccitata, la TD3 agisce come valvola di ritegno in entrambe le direzioni.

When the coil is energized, the valve's poppets opens and allows free flow from 1 to 2 and from 2 to 1.
When the coil is de-energized, the TD3 blocks flows in both directions.

CODICE D'ORDINAZIONE ORDERING CODE

SVCP-S08-TD3- - - - -

GUARNIZIONI / SEAL
N = NBR

REGOLAZIONE / REGULATION
0 = SENZA COMANDO MANUALE / NO MANUAL OVERRIDE
1 = VITE/SCREW

TENSIONE / VOLTAGE
000 = SENZA BOBINA / WITHOUT COIL
D12 = 12 VDC
D24 = 24 VDC
220 = 220 RAC

TIPO CONNETTORE / CONNECTOR TYPE
0 = SENZA BOBINE / WITHOUT COIL
C = CAVI / LEADS
D = DIN 43650 (STD)
G = DEUTSCH DT04-2P
A = AMP JUNIOR

DIMENSIONE CORPO/
SIZE BODY

OMETTERE/OMIT
100=BSP1/4"(pag.18.7)
200=BSP3/8"(pag.18.7)
101=BSP1/4"(pag.18.1)
201=BSP3/8"(pag.18.1)
102=BSP1/4"(pag.18.2)
202=BSP3/8"(pag.18.2)

MATERIALE CORPO/
MATERIAL BODY
OMETTERE/OMIT
S = STEEL
A = ALLUMINUM

COILS

TENSIONE AMMISSIBILE VOLTAGE DUTY RATING	± 10%
FUNZIONAMENTO WORKING DUTY RATING	ED 100%
TEMPERATURA AMBIENTE WORKING ENV. TEMP.	-30°C + 50 °C
CLASSE ISOLAMENTO HEAT INSULATION CLASS	CLASSE H (180°)

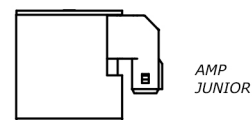
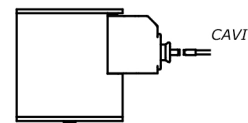
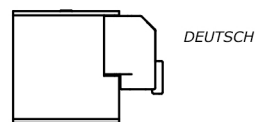
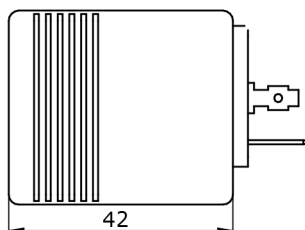
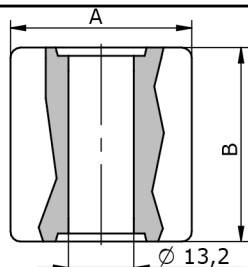

13-39

CL.	TUBO	TENS.	W/Va	A	B		CODICE	CONN		CODICE	CONN
H	13	12Vdc	18	30	39		SH18133930D012D0	DIN 43650		SH18133930D012G0	DEUTSCH
H	13	24Vdc	18	30	39		SH18133930D024D0	DIN 43650		SH18133930D024G0	DEUTSCH
H	13	26Vdc	18	30	39		SH18133930D026D0	DIN 43650		SH18133930D026G0	DEUTSCH
H	13	110 Rac	19	30	39		SF19133930R11D0	DIN 43650			
H	13	12Vdc	18	30	39		SH18133930D012A0	AMPJ		SH18133930D012C0	CAVI
H	13	24Vdc	18	30	39		SH18133930D024A0	AMPJ		SH18133930D024C0	CAVI
H	13	26Vdc	18	30	39		SH18133930D026A0	AMPJ		SH18133930D026C0	CAVI
H	13	12Vdc	22	36	39		SH20133936D012D0	DIN 43650		SH20133936D012G0	DEUTSCH
H	13	24Vdc	22	36	39		SH20133936D024D0	DIN 43650		SH20133936D024G0	DEUTSCH
H	13	26Vdc	22	36	39		SH20133936D026D0	DIN 43650		SH20133936D026G0	DEUTSCH
H	13	220Rac	22	36	39		SH20133936D012D0	DIN 43650			
H	13	12Vdc	22	36	39		SH20133936D012A0	AMPJ		SH20133936D012C0	CAVI
H	13	24Vdc	22	36	39		SH20133936D024A0	AMPJ		SH20133936D024C0	CAVI
H	13	26Vdc	22	36	39		SH20133936D026A0	AMPJ		SH20133936D026C0	CAVI

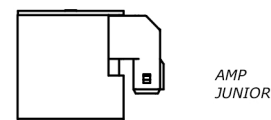
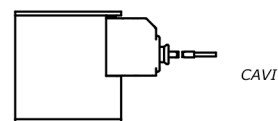
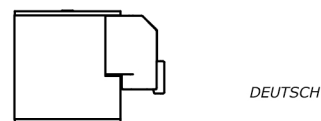
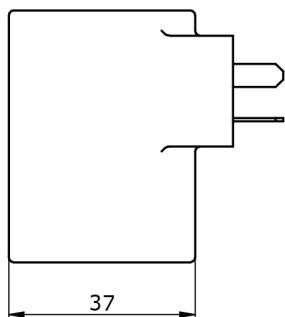
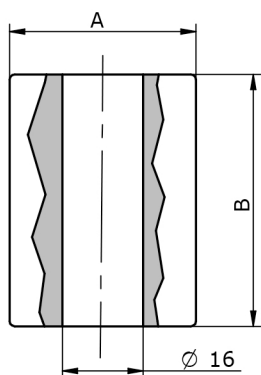

16-50

H	16	12Vdc	26	37	50		SH26165037D012D0	DIN 43650		SH26165037D012G0	DEUTSCH
H	16	24Vdc	26	37	50		SH26165037D024D0	DIN 43650		SH26165037D024G0	DEUTSCH
H	16	26Vdc	26	37	50		SH26165037D026D0	DIN 43650		SH26165037D026G0	DEUTSCH
H	16	12Vdc	26	37	50		SH26165037D012A0	AMPJ		SH26165037D012C0	CAVI
H	16	24Vdc	26	37	50		SH26165037D024A0	AMPJ		SH26165037D024C0	CAVI
H	16	26Vdc	26	37	50		SH26165037D026A0	AMPJ		SH26165037D026C0	CAVI

COLLETTORE PER VALVOLA 3/4-16 UNF, P-T 1/4" (3/8") BSP PER S08
HOUSING FOR 3/4-16 UNF, P-T 1/4" (3/8") BSP FOR S08

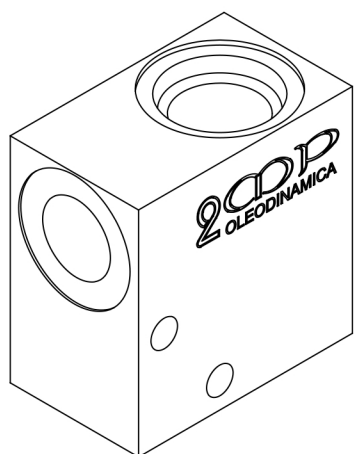

Schema idraulico
Hydraulic diagram

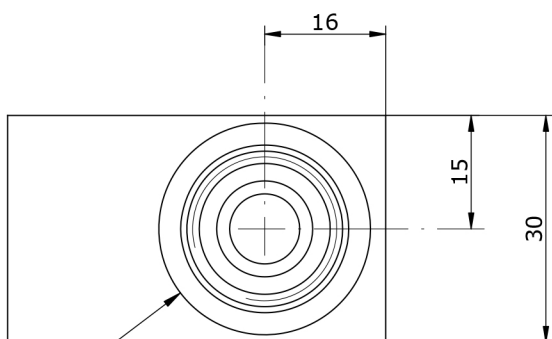
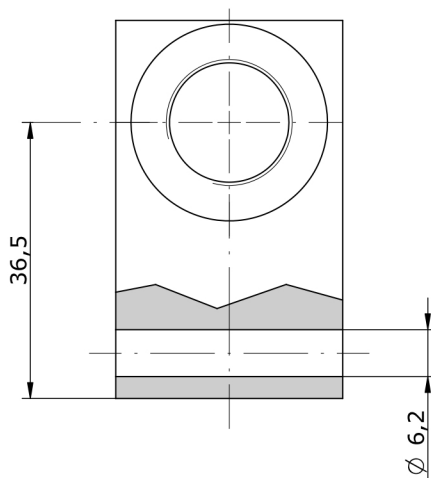
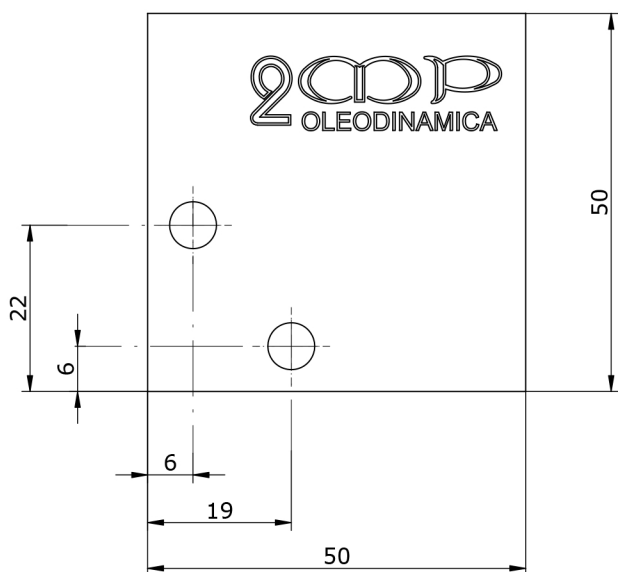
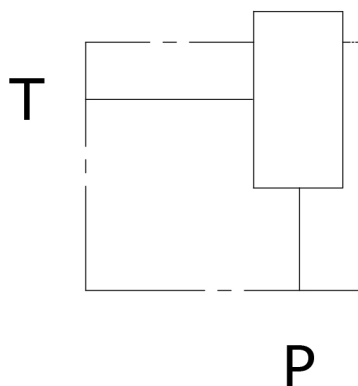

C007

HS_ 06 - ___ - 10

S = STEEL
A = ALUMINUM

14 = BSP 1/4G
38 = BSP 3/8G