

VALVOLA AD INVERSIONE AUTOMATICA NG6
 SELF-REVERSING VALVE NG6

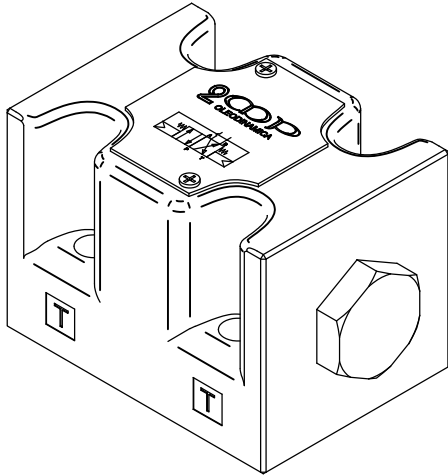

Hydraulic diagram

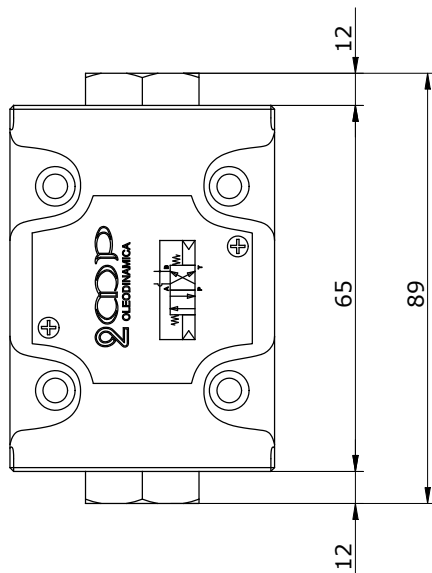
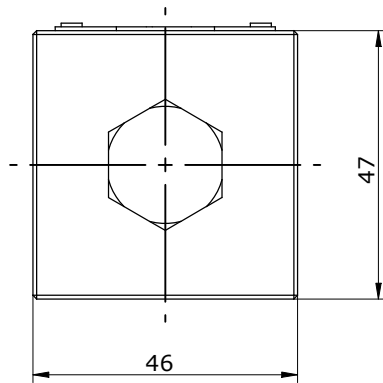
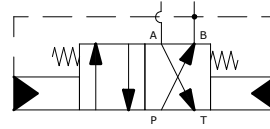

CHARACTERISTICS

Maximum operating pressure on port P	bar	350
Maximum flow rate	bar	50
Minimum allowed flow rate	l/min	30
Minimum allows pressure	l/min	3
Ambient temperature range	°C	-20 / +50
Fluid temperature range	°C	-20 / +80
Fluid viscosity range	cSt	10 ÷ 400
Recommended viscosity	cSt	25
Fluid contamination degree		ISO 4406:1999
Mass	kg	0,9

PRESSURE DROPS

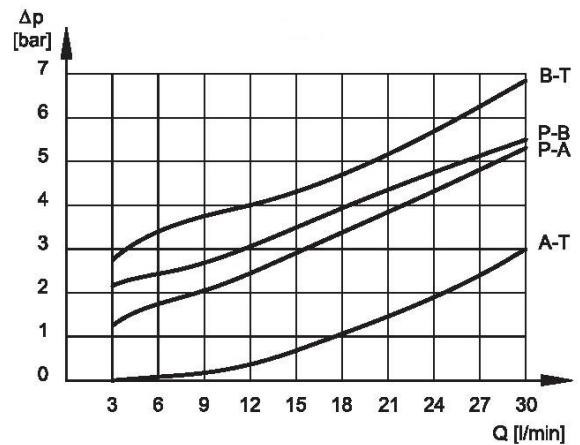

ES 610 - 41