

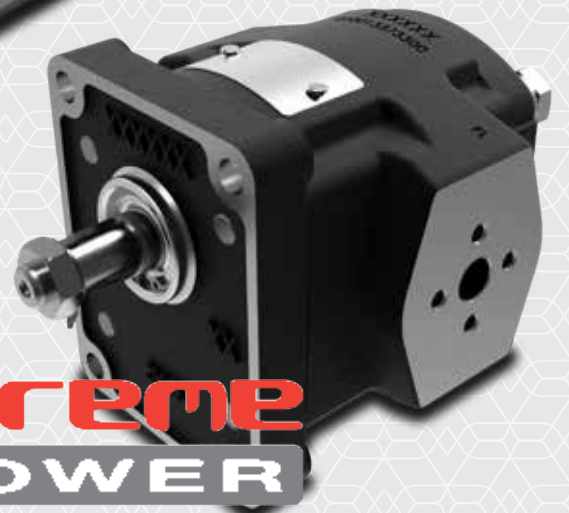

# walvoil

MOTION BY PEOPLE

## Xtreme Series Gear Pumps & Motors



PUMPS & MOTORS

# Xtreme Series

---

## Xtreme Series features

---

### 2XP pump and 2XM motor configurations

New range pumps and motors, with Aluminium body and Aluminium and Cast Iron flanges

Its new modular construction ensures an increased versatility maintaining the same configurations of 2SP Series allowing new options.

- High efficiencies
- Reduced number of components
- Reduced overall dimension
- Increased transmissible torque

### 2XPW pump and 2XMW motor configurations

New range of Cast Iron pumps and motors

These products are particularly suitable for all applications where traditional aluminum pumps are used at the limit of their performance; eg. for installation on mobile equipment intended for heavy duty operating cycles, where pressures or mechanical stresses are typically higher.

Its modular construction allows the same versatility of the Group 2 series with aluminum body, while maintaining the possible configurations in terms of flanges, shafts and integrated valves.

- High efficiencies
- High pressure limits
- Reduced number of components
- Reduced overall dimension

### Additional information

This catalogue shows the product in the most standard configurations.

Please, contact Sales Dpt. for more detailed information or special requests.

### WARNING!

All specifications of this catalogue refer to the standard product at this date.

Walvoil, oriented to a continuous improvement, reserves the right to discontinue, modify or revise the specifications without notice.

WALVOIL IS NOT RESPONSIBLE FOR ANY DAMAGE CAUSED BY AN INCORRECT USE OF THE PRODUCT.

1<sup>st</sup> Edition December 2024

### General Informations

Introduction.....	page 4
Features .....	5
Technical information .....	7
Definitions .....	8
Operative parameters .....	10
Working pressure definitions .....	10
Pressure and rotation speed .....	11
Flow and rotation speed .....	12
Torque and Power diagrams .....	13
Seal rings .....	18
2XP/2XM main dimensional data.....	19
2XPW/2XMW main dimensional data .....	20
Ports threading and connections .....	21

### Single units

Description composition.....	page 23
Standard flange kits .....	26
Gear support kits .....	30
Driving gear shafts .....	31
Ø22 mm (Ø0.87 in) shaft and flange configuration.....	37
Flange kit with outboard bearing (SUP version).....	38
Driven gears .....	42
Standard bodies .....	42
Special and dedicated bodies .....	43
Standard cover kits .....	44
Special cover kits .....	48

### Tandem pumps

Tandem pumps general informations.....	page 57
Tandem kits - list and specifications .....	59
Second stage dedicated driving gears .....	60
2XP or 2XPW primary stage .....	61
Group 3 primary stage.....	70

Complete pumps ordering codes .....	page 77
Complete motors ordering codes .....	79
Secondary stage ordering codes .....	80
Assembling screws ordering codes .....	84
Product identification.....	86

## Introduction

The standard range of **Xtreme** gear pump consists on 11 sizes: from 4 to 31 cm<sup>3</sup>/rev (0.244 to 1.89 in<sup>3</sup>/rev).

With displacement from 11 cm<sup>3</sup>/rev (0.671 in<sup>3</sup>/rev) the pump, or the motor, can be assembled with cast iron body option. In this case the pump can work up to 270 bar (3900 psi) of working pressure. Several new features are included in these new platforms: the possibility to have the 3/4 shafts versions, the SAE 13T shaft and an improved efficiency of the pump.

A large amount of optimizations are included in the motor versions, that has now a reduced starting pressure and an higher transmissible torque.

Compared to **START** series, **Xtreme** series has several new features.

These new options, allows 6 majors improvements:

- FEMALE SPLINE Compact Tandem Capability (-15 mm / -0.59 in on double pump)
- SAE B FRONT FLANGE
- HIGHER SHAFT DIAMETER; up to Ø22 mm (0.866 in) and up to 100 Nm (73.7 lbf) between stages
- SEPARATE STAGES VERSION double sealing separate stages
- NEW SHAFTS SAE 11T, 3/4 inch keyed
- CAST IRON AND ALUMINUM BODY OPTION same gears and plates
- New REVERSIBLE SEALING



## Construction features

To reach the targets and simplify the installations in the active systems, **Xtreme** and **Xtreme power** are using the traditional **START** components when possible. Starting from the same flange, it's possible to introduce the new generation of plates and gears.

For the aluminum body option is therefore possible to use the same body of **START** Series, while cast iron body can be installed on **Xtreme power** only.

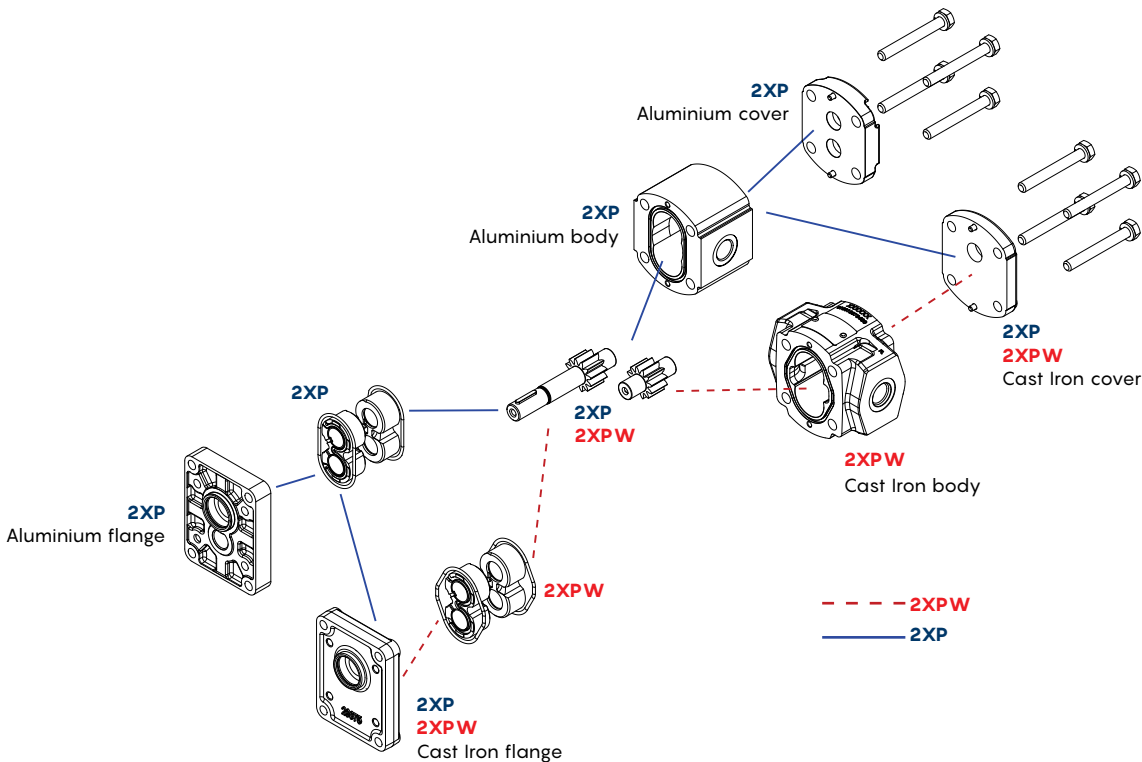

**Xtreme** is available with aluminium body options (2XP) and cast iron body options (2XPW) and has a complete new set of gear, improving compactness & flexibility. A new generation of plates is able to succeed in the most demanding applications.

**Working conditions**

This catalogue shows technical specifications and diagrams measured with mineral oil of 46 mm<sup>2</sup>/s (46 cSt) viscosity at 40°C (104°F) temperature.

		2XP	2XPW
<b>Displacement</b>		from 4.1 to 31.5 cm <sup>3</sup> /rev <i>from 0.25 to 1.92 in<sup>3</sup>/rev</i>	from 11.2 to 31.5 cm <sup>3</sup> /rev <i>from 0.68 to 1.92 in<sup>3</sup>/rev</i>
<b>Max continuous pressure</b>	up to	250 bar - 3600 psi	270 bar - 3900 psi
<b>Fluid</b>		hydraulic mineral oil-based	
<b>Fluid temperature range</b>	continuous with NBR (buna N) seals	from -20 to +80 °C <i>from -4 to +176 °F</i>	
	continuous with FPM (viton) seals	from -15 to +100 °C <i>from +5 to +212 °F</i>	
<b>Viscosity</b>	Recommended	from 15 to 92 mm <sup>2</sup> /s (cSt)	
	Permitted for starting	800 mm <sup>2</sup> /s (cSt)	
<b>Max level of contamination</b>	Recommended for operating pressure > 150 bar (2150 psi)	20/18/15 ISO 4406 <i>class 9 (NAS 1638)</i>	
	Recommended for operating pressure < 150 bar (2150 psi)	21/18/15 ISO 4406 <i>class 10 (NAS 1638)</i>	

**Displacements**

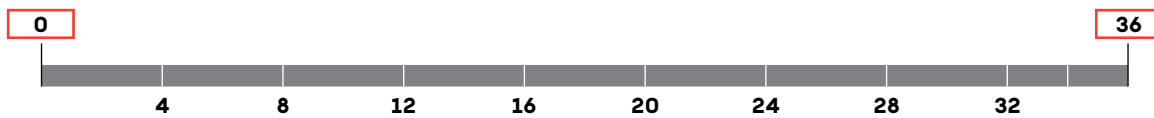

Group 2XP/2XM	Displacement	
	cm <sup>3</sup> /rev	in <sup>3</sup> /rev
040	4.1	0.25
060	6.1	0.37
080	8.7	0.53
110	11.2	0.68
140	14.2	0.86
160	16.8	1.02
190	19.8	1.20
220	22.9	1.39
260	26.4	1.61
290	29.1	1.77
310	31.5	1.92

Group 2XPW/2XMW	Displacement	
	cm <sup>3</sup> /rev	in <sup>3</sup> /rev
110	11.2	0.68
140	14.2	0.86
160	16.8	1.02
190	19.8	1.20
220	22.9	1.39
260	26.4	1.61
290	29.1	1.77
310	31.5	1.92

## Features

### Flanges range

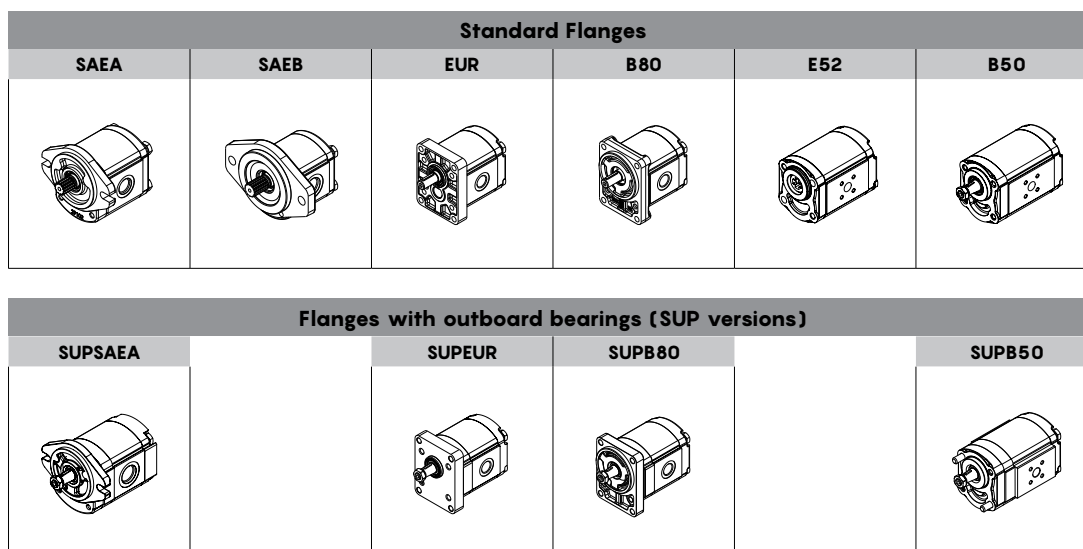

NOTE: for informations, specifications and dimensions of **SUP** type flanges see related pages (from 27 to 32)

### Shaft / Standard flange combination

For combination of shafts and flanges with outboard bearing see related pages.

Shafts				Standard flanges					
Type	Description	Diameter (shaft seal)	Transmitted torque (max)	SAEA	SAEB	EUR	B80	E52	B50
10	Tapered 1:8	Ø18 mm - 0.71 in	140 Nm - 103 lbft	●	●	●	●	—	●
11	Tapered 1:5	Ø18 mm - 0.71 in	140 Nm - 103 lbft	●	●	●	●	—	●
12	EUR parallel shaft	Ø18 mm - 0.71 in	80 Nm - 59 lbft	●	●	●	●	—	●
13	SAEA parallel shaft	Ø18 mm - 0.71 in	90 Nm - 66 lbft	●	●	●	●	—	●
14	SAEA 9T splined	Ø18 mm - 0.71 in	100 Nm - 74 lbft	●	●	●	●	—	●
15	DIN5482 9T (26/24) splined	Ø18 mm - 0.71 in	100 Nm - 74 lbft	●	●	●	●	—	●
17	Dihedral claw	Ø18 mm - 0.71 in	80 Nm - 59 lbft	—	—	—	—	●	—
30	SAE 11T splined	Ø20 mm - 0.79 in	180 Nm - 133 lbft	●	—	—	—	—	—
31	SAE 3/4" (53.8 mm - 2.12 in) parallel shaft	Ø20 mm - 0.79 in	140 Nm - 103 lbft	●	—	—	—	—	—
32	SAE 3/4" (31 mm - 1.22 in) parallel shaft	Ø20 mm - 0.79 in	100 Nm - 74 lbft	●	—	—	—	—	—
40	SAE 10T splined	Ø18 mm - 0.71 in	130 Nm - 96 lbft	●	●	—	—	—	—
45	SAEB 13T splined	Ø22 mm - 0.87 in	280 Nm - 207 lbft	—	●	—	—	—	—

● = available — = not available

NOTE: for more informations please see dedicated pages (from 31 to 37)

### Hydraulic fluid

It is advisable to use hydraulic oils of mineral origin with anti-foaming, antiwear, anti-oxidant and anti-corrosion characteristics and rapid air removal properties and a high viscosity index;

- Start-up viscosity limit 2000 mm<sup>2</sup>/s (2000 cSt)
- Recommended viscosity 15÷92 mm<sup>2</sup>/s (15÷92 cSt)
- Max. operating viscosity 750 mm<sup>2</sup>/s (700 cSt)

During normal operation, the oil temperature must be between 20°C (68°F) and 65°C (149°F) with limit values between -20°C (-4°F) and 80°C (176°F) with NBR seal and limit values between -15°C (5°F) and 100°C (212°F) with Viton seal.

### Suction pressure

The allowed working pressure supplied must be in the range 0.7 - 2 bar (10.2 - 29 psi) [absolute].

For higher values (up to 30 bar / 435 psi), it is necessary to use sealing ring for high pressures.

Particular attention must be given to the sizing of rigid or flexible pipes. avoiding disproportionate lengths, sudden variations in cross section or small curvature radius, in any case selecting pipe cross-sections that guarantee an oil speed between 0.6 and 2 m/s (1.97 and 6.56 ft/s)

### Filtration

In order to eliminate any oil impurity and to guarantee a longer duration of the pump, the system must be equipped with effective filtration, whose operation must be periodically checked.

The recommended filtration levels are as follows:

$\Delta p < 150$  bar (2175 psi):

**21/19/16 (ISO 4406) - class 10 (NAS 1638)**

150 bar (2175 psi) <  $\Delta p < 210$  bar (3050 psi):

**20/18/15 (ISO 4406) - class 9 (NAS 1638)**

$\Delta p > 210$  bar (3050 psi):

**19/17/14 (ISO 4406) - class 8 (NAS 1638)**

### Installation notes

Before starting the system setting, some precautions are recommended:

- Check that the direction of rotation is consistent with the drive shaft one.
- Remove all dirt, chips and all foreign bodies from flanges connecting inlet and delivery ports.
- Protect the drive shaft sealing ring during pump painting; check that the contact area between ring and shaft is clean: dust or abrasive sediments could accelerate the wear and cause leakages.
- Check that there are no misalignments between the pump/motor shaft and the main shaft.
- With radial and/or axial loads on the pump/motor shaft (such as when driving is carried out through pulleys or chains) use the configurations with outboard bearings (SUP type flange).
- The coupling joint between the spline shafts has to be properly lubricated, free to move axially and of a suitable length to cover both motor and pump shafts.

Notes:

- Do not start the system under load at low temperatures or after long stops.
- Check the whole system filling by bleeding off the whole air amount after few minutes of system working.
- Increase the pressure until you reach the operating values by keeping checked the fluid and the moving parts temperature and the rotation speed. Maintain the set values within the limits specified in this catalogue.

## Definitions

### Pump wise rotation

The rotation wise is defined as **S** (counter-clockwise) or **D** (clockwise) by observing the shaft from the front. In case of anti-clockwise rotation **S** the suction will be to the right of the drive shaft while the delivery will be to your left; the opposite will be for pump with **D** wise rotation. When ordering, it is necessary to specify the required rotation; direction or it is possible to modify the internal structure as illustrated on the next page (reversal).

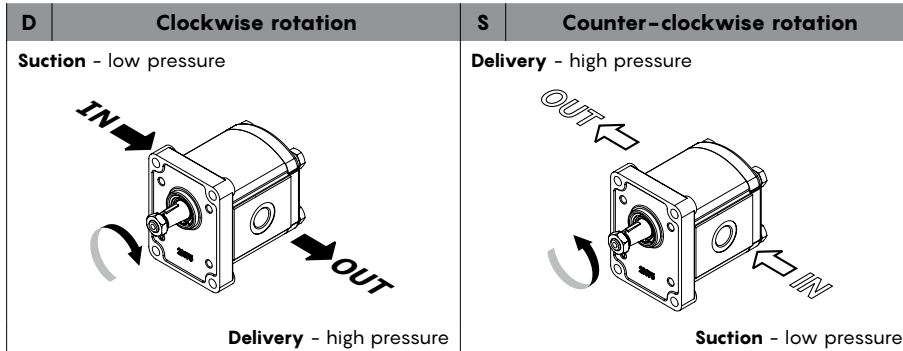

### Motor wise rotation

The rotation wise is defined by observing the shaft frontally: **S** (counter-clockwise) and **D** (clockwise).

In case of **S** counter-clockwise rotation, outlet port will be the left of the shaft while inlet port to its right; the opposite layout is used in case of **D** clockwise rotation.

When ordering please specify the required rotation wise of monodirectional motors, otherwise modify the internal assembly layout as indicated on the next page (wise rotation reversal).

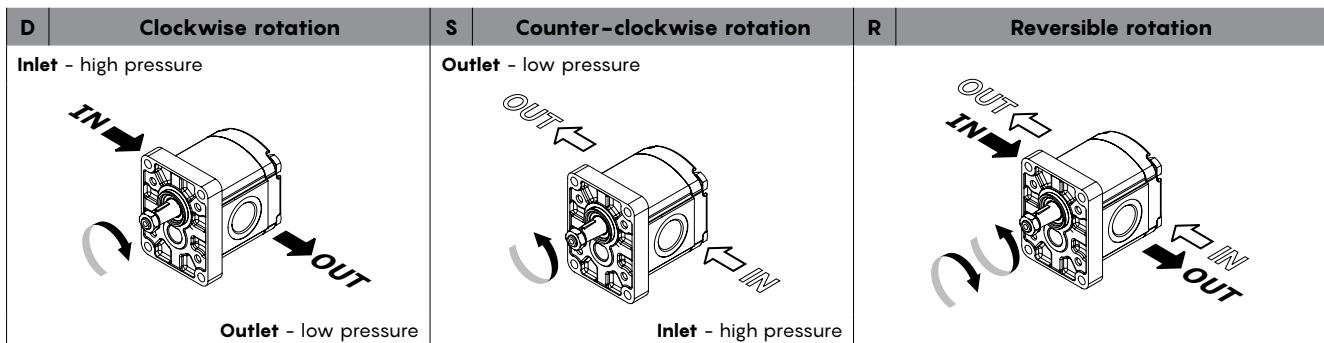



**Pump/motor rotation reversal**

**How to invert the wise rotation:**

- Disassemble pump or unidirectional motor as shown in pic. 1.
- Pull off C - D gears and reassemble them according to pic. 2.
- Reassemble B bushing as before.
- Reverse the A flange and reassemble the pump by tightening the screws by dynamometric wrench.

The drawing represents the 2XP pump configuration example, for the 2XPW pump the operations are the same.. For technical informations please contact our Sales Dpt..

NOTE: the rotation reversal procedure is not applicable to reversible motors

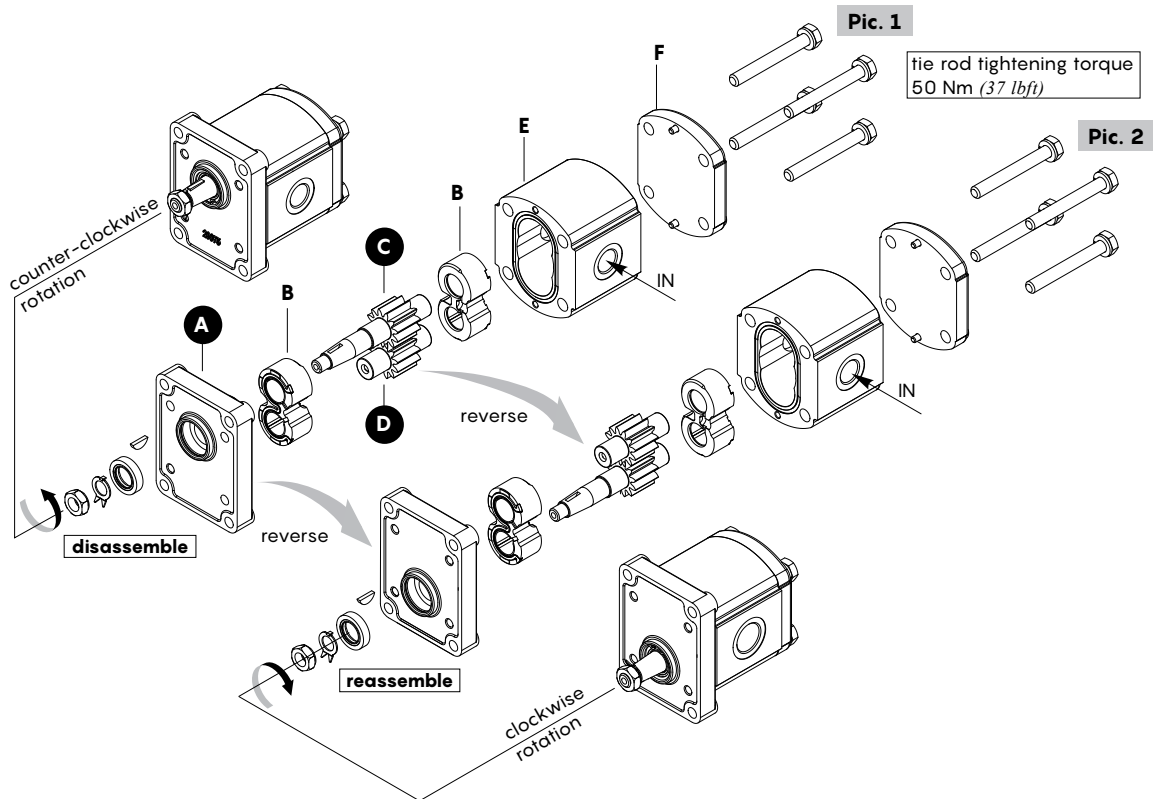

**Ports position**

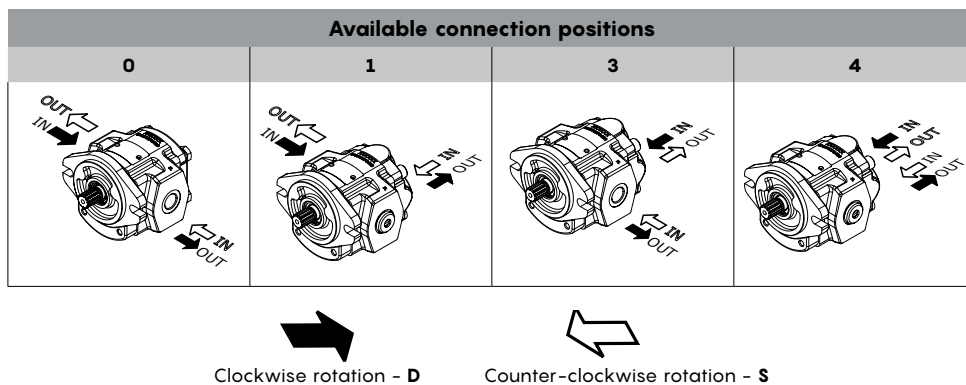

### Operative parameters

Hydraulic measures		
<b>Q</b>	Flow	(l/min - USgpm)
<b>M</b>	Torque	(Nm - lbf <sup>t</sup> )
<b>P</b>	Power	(kW - HP)
<b>V</b>	Displacement	(cm <sup>3</sup> /rev - in <sup>3</sup> /rev)
<b>n</b>	Speed	(rpm - min <sup>-1</sup> )
<b>Δp</b>	Pressure	(bar - psi)
<b>η<sub>v</sub></b>	Volumetric efficiency	
<b>η<sub>m</sub></b>	Mechanical efficiency	
<b>η<sub>t</sub></b>	Overall efficiency	

Conversion factor	
1 l/min	0.2641 USgpm
1 Nm	8.851 lbin
1 Nm	0.7375 lbf <sup>t</sup>
1 N	0.2248 lbf
1 kW	1.34 HP
1 cm <sup>3</sup> /rev	0.061 in <sup>3</sup> /rev
1 bar	14.5 psi
1 mm	0.0394 in
1 kg	2.205 lbs

### Working pressure definitions

The pumps can be subjected to the P1, P2 or P3 pressures shown in the performance tables.

The following diagram illustrates the definitions and applicability by respecting the included rotation speed limits.

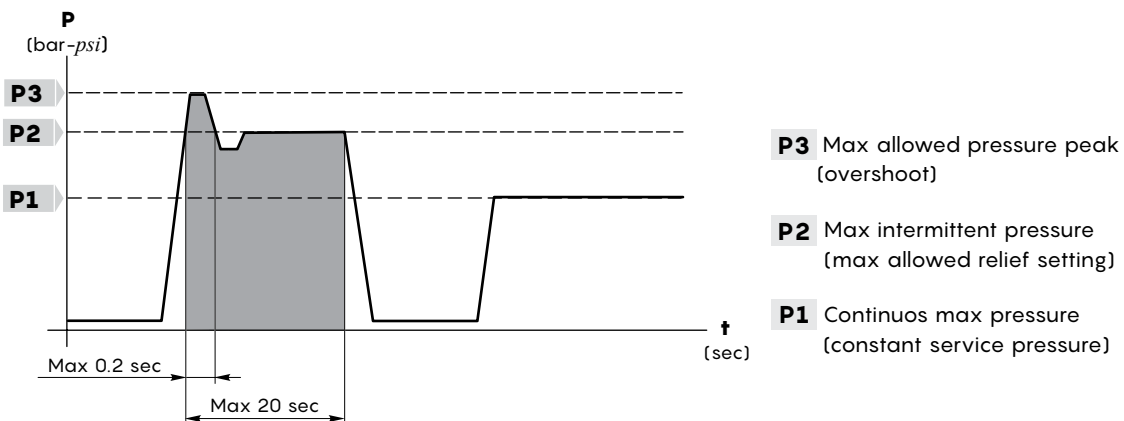

**Pressure and rotation speed**

**Aluminium body**

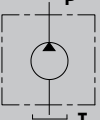
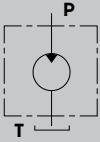
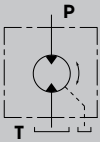
Symbol	Type	Displacement		P1 Max continuous pressure		P2 Max intermittent pressure		P3 Max peak pressure		Rotation speed	
		cm <sup>3</sup> /rev	in <sup>3</sup> /rev	bar	psi	bar	psi	bar	psi	max rpm	min rpm
<b>Unidirectional pump/motor type</b>											
	<b>2XP/2XM 040</b>	4.1	0.25	250	3600	270	3900	290	4200	4000	500
	<b>2XP/2XM 060</b>	6.1	0.37	250	3600	270	3900	290	4200	4000	500
	<b>2XP/2XM 080</b>	8.7	0.53	250	3600	270	3900	290	4200	3500	500
	<b>2XP/2XM 110</b>	11.2	0.68	250	3600	270	3900	290	4200	3500	500
	<b>2XP/2XM 140</b>	14.2	0.86	250	3600	270	3900	290	4200	3500	500
	<b>2XP/2XM 160</b>	16.8	1.02	230	3350	240	3500	250	3600	3500	500
	<b>2XP/2XM 190</b>	19.8	1.20	210	3050	220	3200	230	3350	3500	500
	<b>2XP/2XM 220</b>	22.9	1.39	190	2750	200	2900	210	3050	3000	500
	<b>2XP/2XM 260</b>	26.4	1.61	170	2450	180	2600	190	2750	3000	500
	<b>2XP/2XM 290</b>	29.1	1.77	150	2150	160	2300	170	2450	2500	500
	<b>2XP/2XM 310</b>	31.5	1.92	130	1900	140	2000	150	2150	2500	500
	<b>Reversible motor type</b>										
	<b>2XM 040</b>	4.1	0.25	250	3600	270	3900	290	4200	4000	500
	<b>2XM 060</b>	6.1	0.37	250	3600	270	3900	290	4200	4000	500
	<b>2XM 080</b>	8.7	0.53	250	3600	270	3900	290	4200	3500	500
	<b>2XM 110</b>	11.2	0.68	250	3600	270	3900	290	4200	3500	500
	<b>2XM 140</b>	14.2	0.86	250	3600	270	3900	290	4200	3500	500
	<b>2XM 160</b>	16.8	1.02	230	3350	240	3500	250	3600	3500	500
	<b>2XM 190</b>	19.8	1.20	210	3050	220	3200	230	3350	3500	500
	<b>2XM 220</b>	22.9	1.39	190	2750	200	2900	210	3050	3000	500
	<b>2XM 260</b>	26.4	1.61	170	2450	180	2600	190	2750	3000	500
	<b>2XM 290</b>	29.1	1.77	150	2150	160	2300	170	2450	2500	500
	<b>2XM 310</b>	31.5	1.92	130	1900	140	2000	150	2150	2500	500

**Cast iron body**

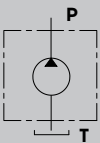
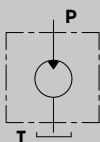
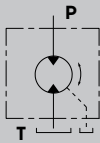
Symbol	Type	Displacement		P1 Max continuous pressure		P2 Max intermittent pressure		P3 Max peak pressure		Rotation speed		
		cm <sup>3</sup> /rev	in <sup>3</sup> /rev	bar	psi	bar	psi	bar	psi	max rpm	min rpm	
<b>Unidirectional pump/motor type</b>												
	<b>2XPW/2XMW 110</b>	11.2	0.68	270	3900	290	4200	300	4350	3500	500	
	<b>2XPW/2XMW 140</b>	14.2	0.86	270	3900	290	4200	300	4350	3500	500	
	<b>2XPW/2XMW 160</b>	16.8	1.02	250	3600	270	3900	280	4050	3500	500	
	<b>2XPW/2XMW 190</b>	19.8	1.20	250	3600	270	3900	280	4050	3500	500	
	<b>2XPW/2XMW 220</b>	22.9	1.39	250	3600	270	3900	280	4050	3000	500	
	<b>2XPW/2XMW 260</b>	26.4	1.61	230	3350	250	3600	260	3750	3000	500	
	<b>2XPW/2XMW 290</b>	29.1	1.77	200	2900	220	3200	230	3350	2500	500	
	<b>2XPW/2XMW 310</b>	31.5	1.92	190	2750	210	3050	220	3200	2500	500	
	<b>Reversible motor type</b>											
		<b>2XMW 110</b>	11.2	0.68	250	3600	270	3900	280	4050	3500	500
		<b>2XMW 140</b>	14.2	0.86	250	3600	270	3900	280	4050	3500	500
		<b>2XMW 160</b>	16.8	1.02	250	3600	270	3900	280	4050	3500	500
<b>2XMW 190</b>		19.8	1.20	250	3600	270	3900	280	4050	3500	500	
<b>2XMW 220</b>		22.9	1.39	250	3600	270	3900	280	4050	3000	500	
<b>2XMW 260</b>		26.4	1.61	230	3350	250	3600	260	3750	3000	500	
<b>2XMW 290</b>		29.1	1.77	200	2900	220	3200	230	3350	2500	500	
<b>2XMW 310</b>		31.5	1.92	190	2750	210	3050	220	3200	2500	500	

## Flow and rotation speed

### 2XP - 2XPW Pumps

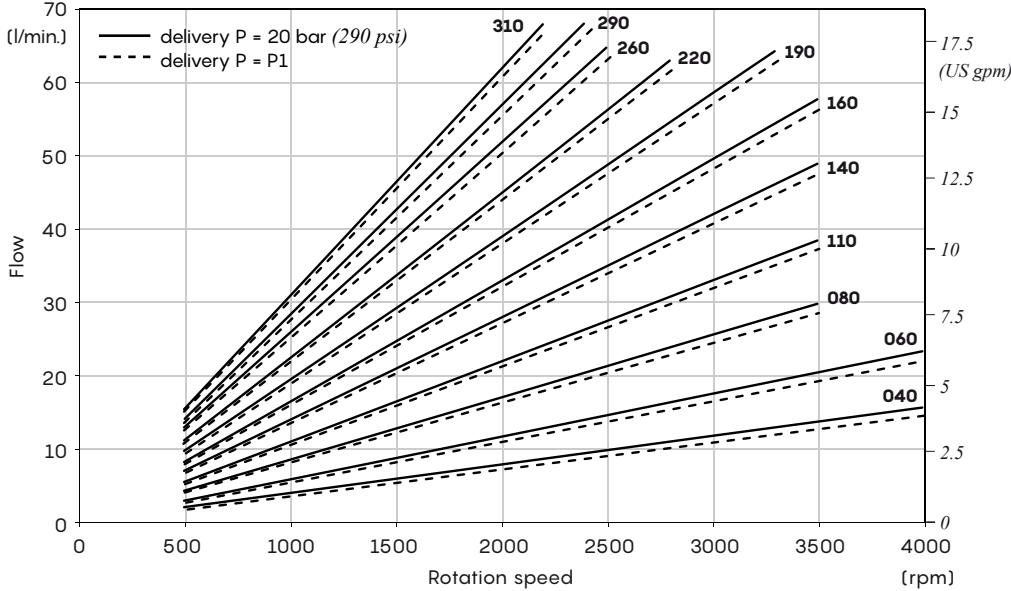

**Reference values\***

$$\eta_v \approx 0.97$$

$$\eta_m \approx 0.88$$

$$\eta_t = \eta_v \cdot \eta_m \approx 0.85$$

### 2XM - 2XMW Motors

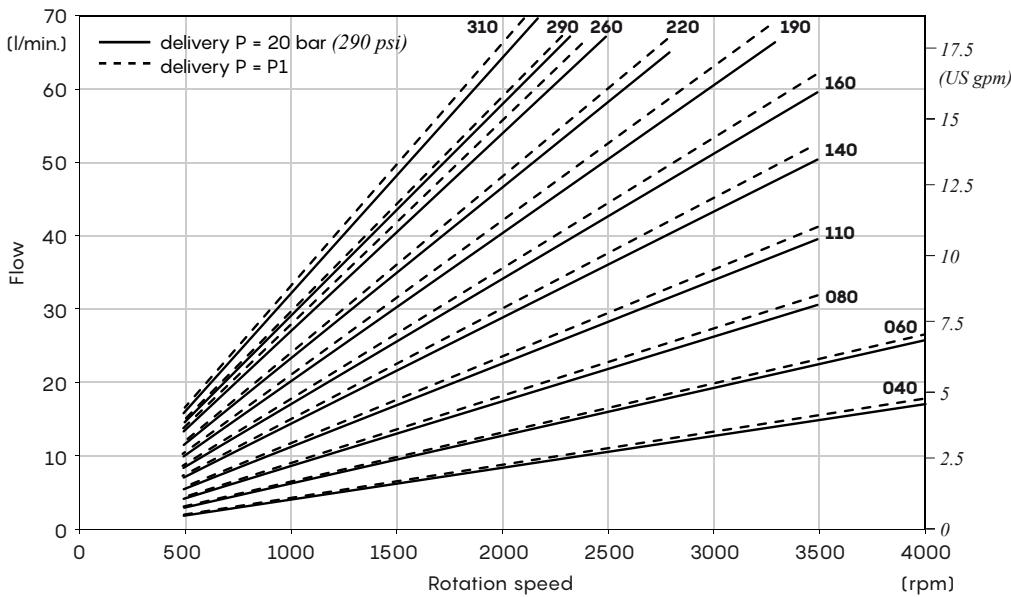

**Reference values\***

$$\eta_v \approx 0.96$$

$$\eta_m \approx 0.85$$

$$\eta_t = \eta_v \cdot \eta_m \approx 0.82$$

Hydraulic measures	
<b>Q =</b>	$\frac{V \cdot \eta_v \cdot n}{1000}$ (l/min)
	$\frac{V \cdot \eta_v \cdot n}{231}$ (USgpm)
<b>M =</b>	$\frac{\Delta p \cdot V}{62.83 \cdot \eta_m}$ (Nm)
	$\frac{\Delta p \cdot V}{2 \cdot 3.14 \cdot \eta_m}$ (lb.in)

Hydraulic measures	
<b>P =</b>	$\frac{\Delta p \cdot V \cdot n}{600 \cdot 1000 \cdot \eta_t}$ (kW)
	$\frac{\Delta p \cdot V \cdot n}{395934 \cdot \eta_t}$ (HP)

NOTE: [\*] 2XP160@1500 rpm with ISO VG46 Oil @40°C (104 °F)

Torque and Power diagrams

2XP pumps

2XP 040

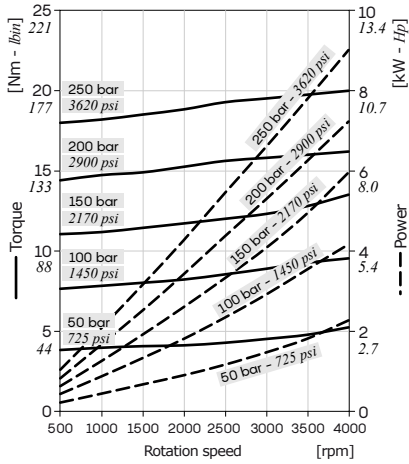

2XP 060

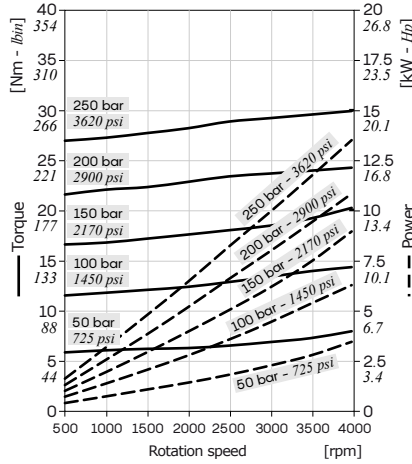

2XP 080

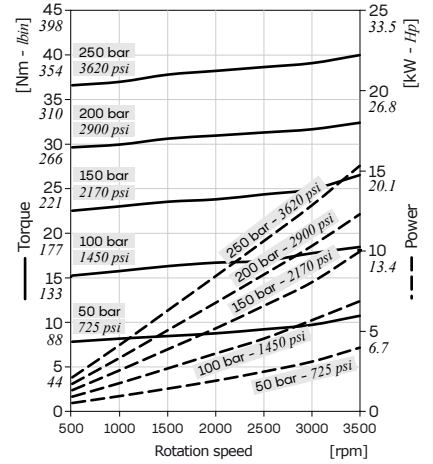

2XP 110

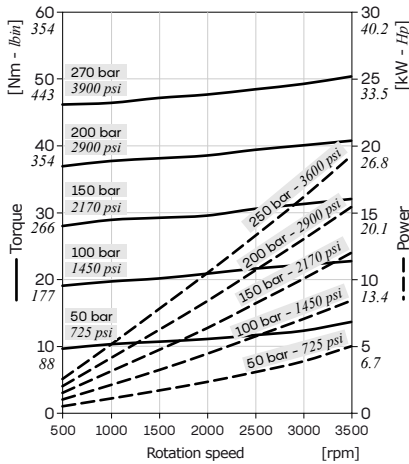

2XP 140

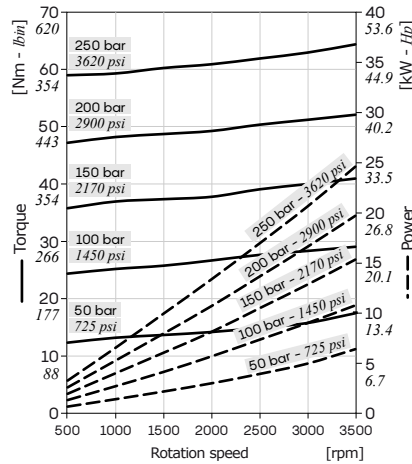

2XP 160

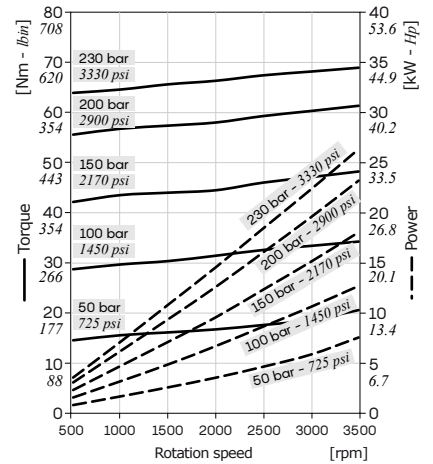

2XP 190

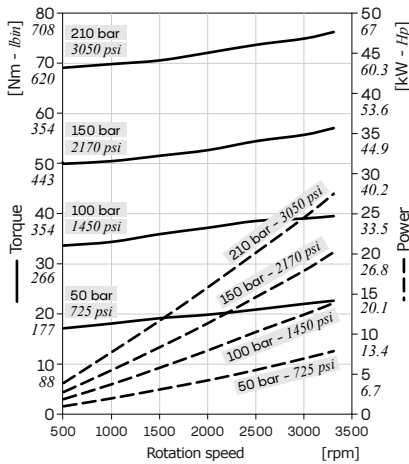

2XP 220

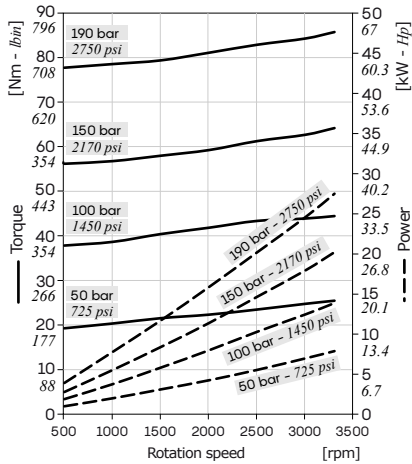

2XP 260

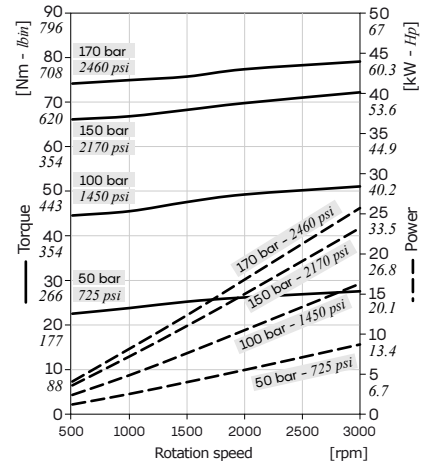

### Torque and Power diagrams

#### 2XP pumps

##### 2XP 290

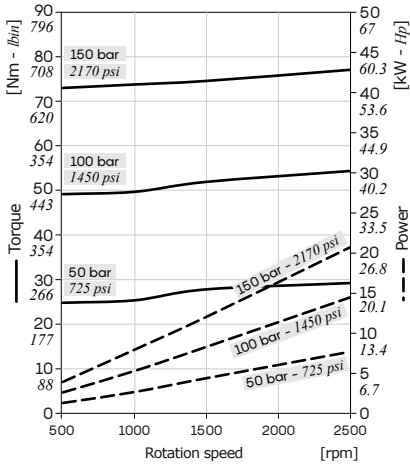

##### 2XP 310

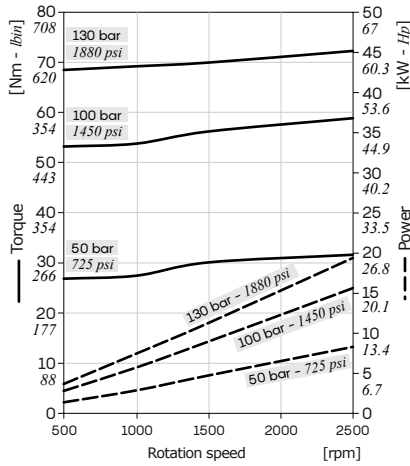

#### 2XM motors

##### 2XM 040

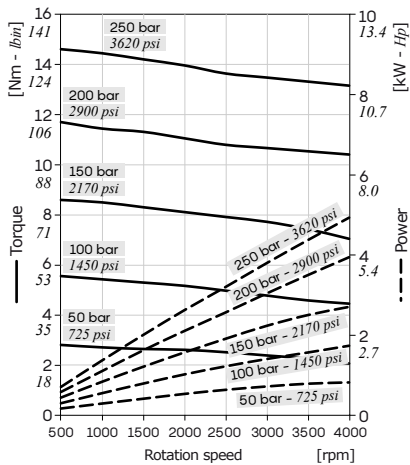

##### 2XM 060

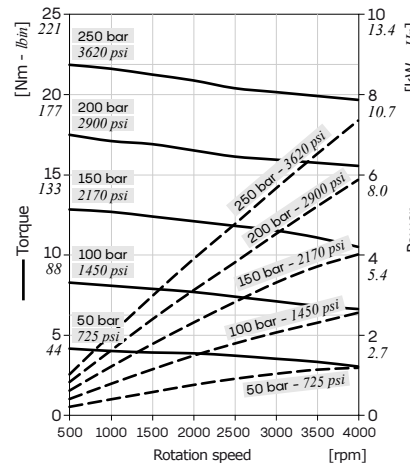

##### 2XM 080

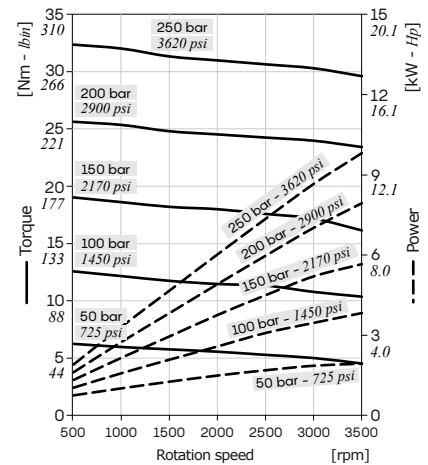

##### 2XM 110

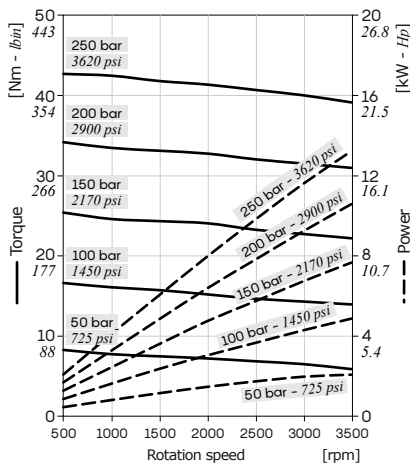

##### 2XM 140

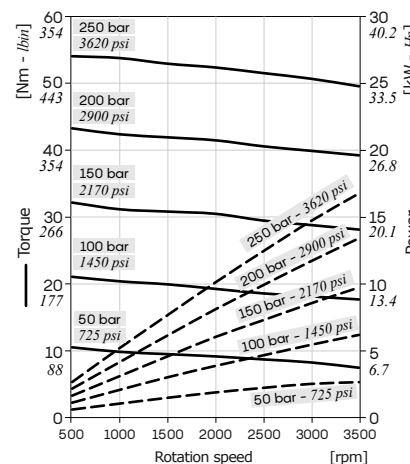

##### 2XM 160

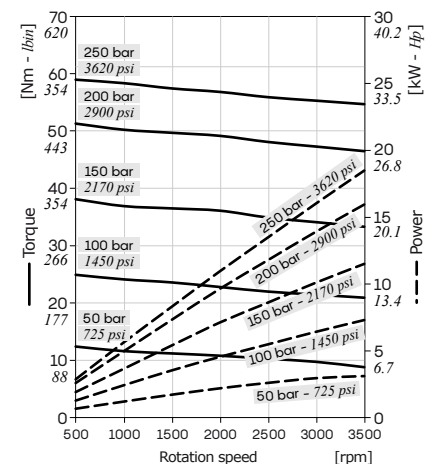

Torque and Power diagrams

2XM motors

2XM 190

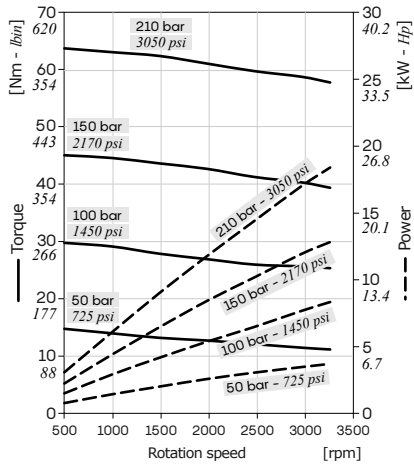

2XM 220

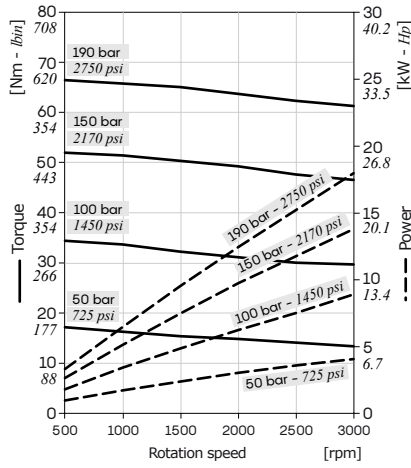

2XM 260

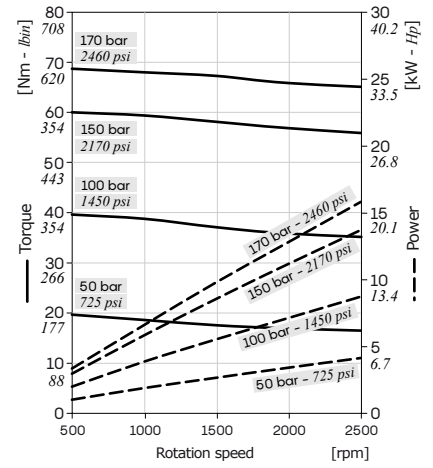

2XM 290

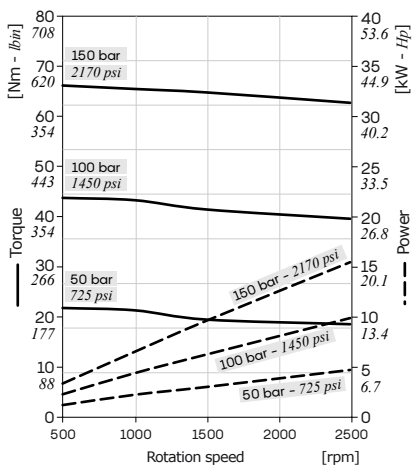

2XM 310

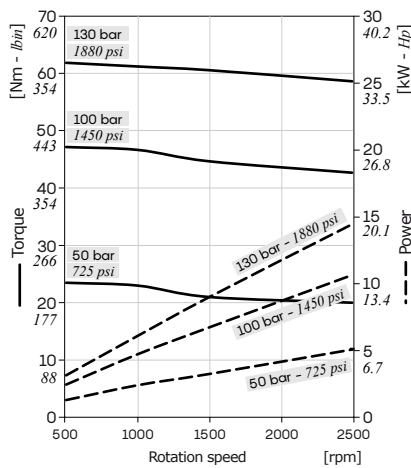

### Torque and Power diagrams

#### 2XPW pumps

#### 2XPW 110

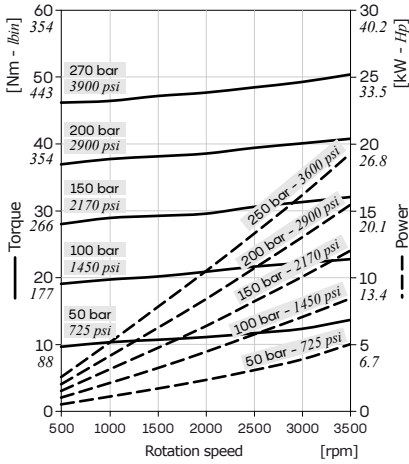

#### 2XPW 140

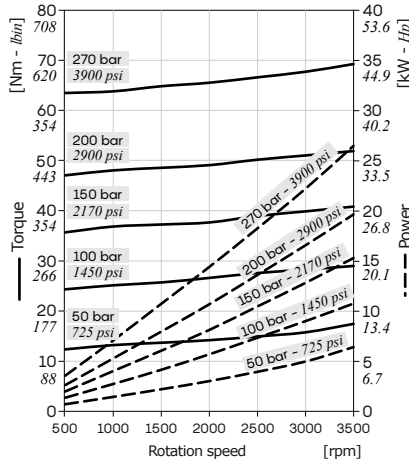

#### 2XPW 160

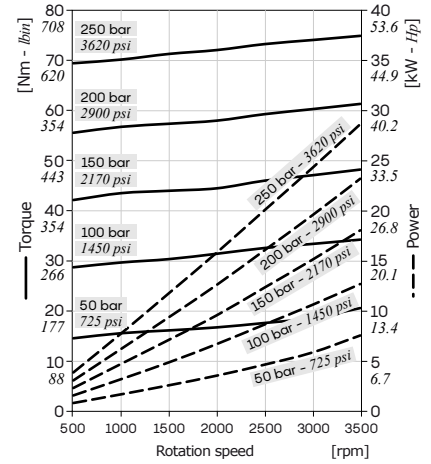

#### 2XPW 190

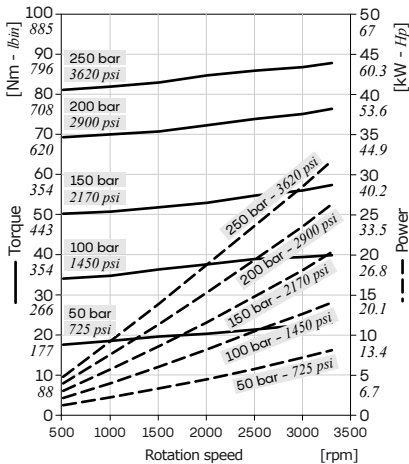

#### 2XPW 220

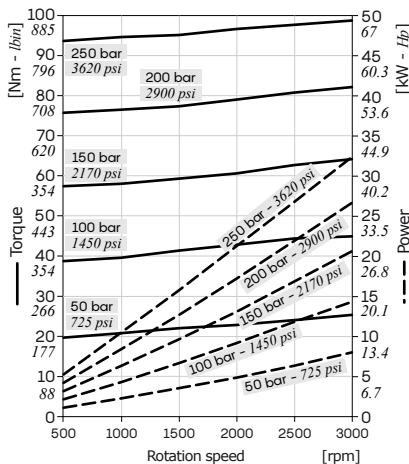

#### 2XPW 260

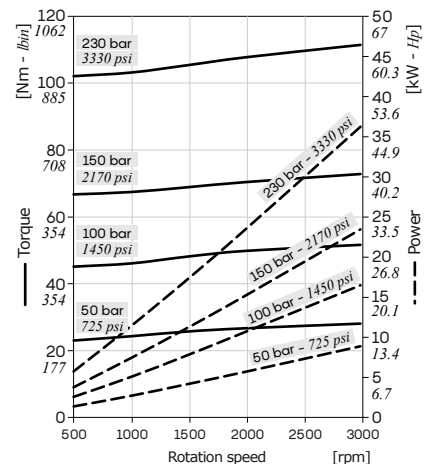

#### 2XPW 290

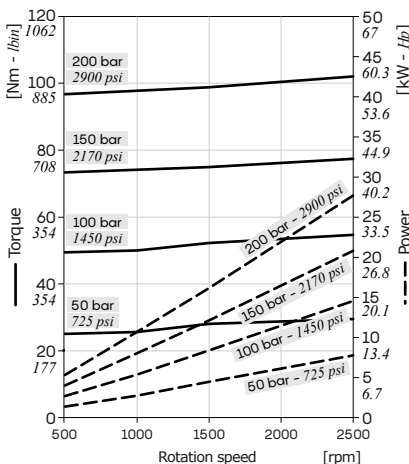

#### 2XPW 310

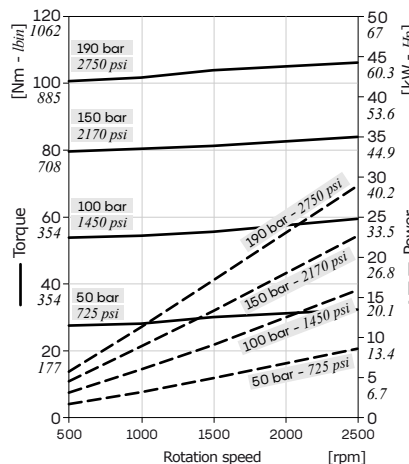



Torque and Power diagrams

2XMW motors

2XMW 110

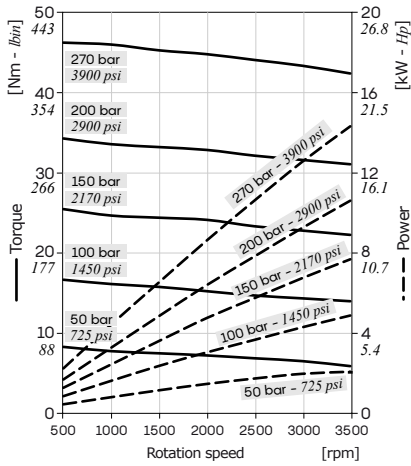

2XMW 140

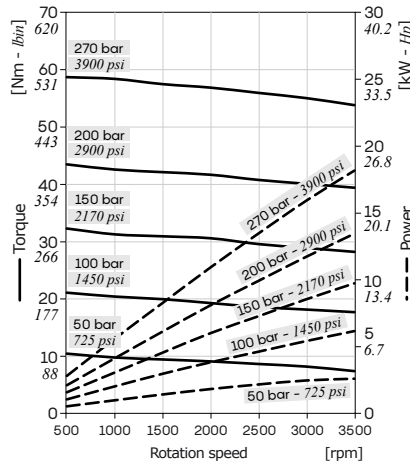

2XMW 160

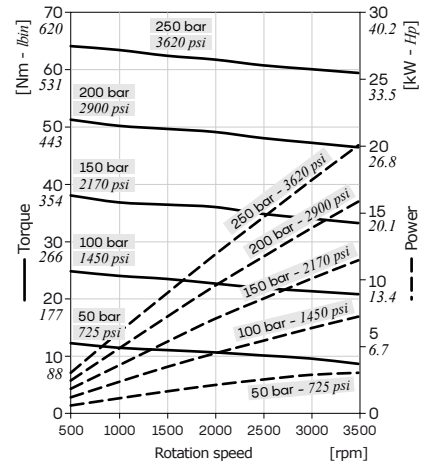

2XMW 190

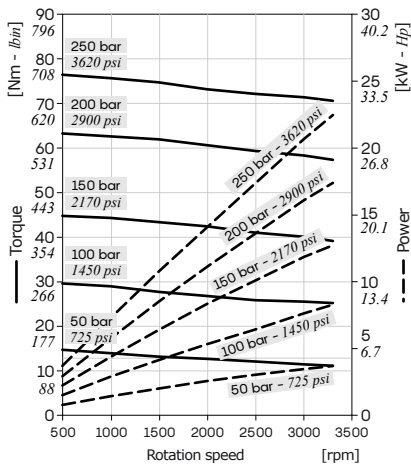

2XMW 220

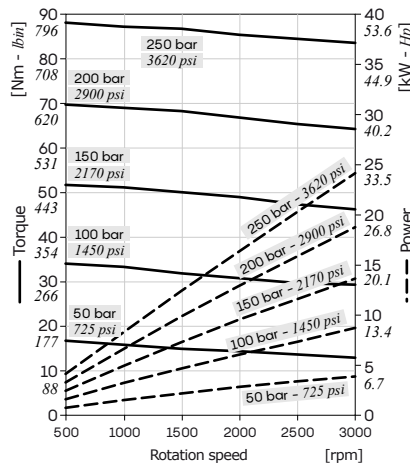

2XMW 260

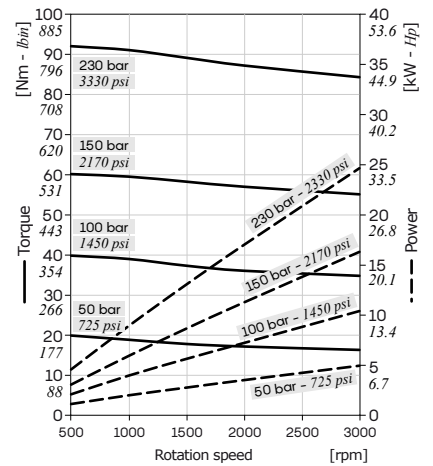

2XMW 290

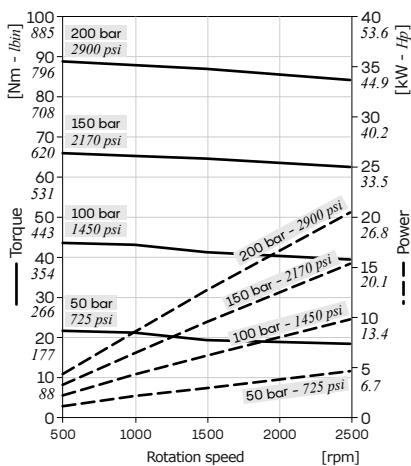

2XMW 310

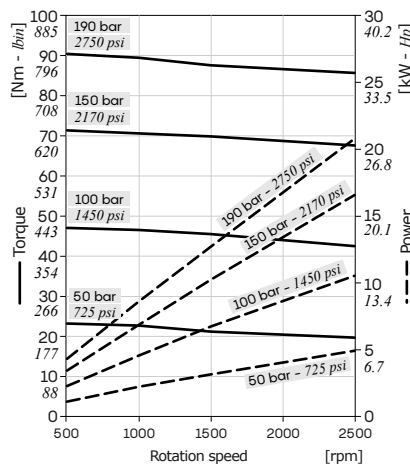

## Seal rings

### Shaft sealing (main sealing)

Shaft seal configuration	Pressure code			
	A	B	H	K
		Pumps	Pumps - Motors motors with external drain	Unidirectional motors
Without shaft seal	*	-	-	-
With shaft seal (standard)	-	Max pressure up to 3 bar (43.5 psi) @ 1000 rpm	Max pressure up to 8 bar (116 psi) @ 1000 rpm	Max pressure up to 30 bar (435 psi) @ 1000 rpm
With shaft seal and dust seal (type "2")	-	0.9 bar (13 psi) @ 4000 rpm	2.6 bar (37.7 psi) @ 4000 rpm	10.6 bar (153.7 psi) @ 4000 rpm

\*\* = available    "-" = not available

#### Without shaft seal

Flange example: E52

2XP-A-040-D-E52CX-A-N-17-0-G12G12

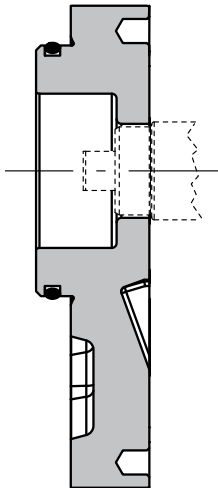

#### With shaft seal: standard flange kit

Flange example: EUR

2XP-A-310-D-EUR-B-N-10-0-N19N13

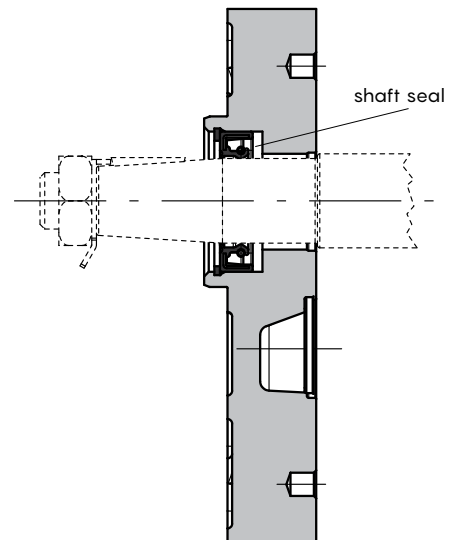

#### With shaft seal and dust seal

Flange example: EUR

2XP-A-310-D-EUR2-BK-N-10-0-N19N13

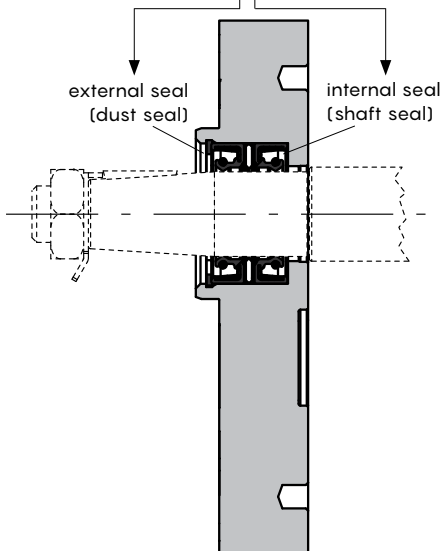

NOTE: NBR and FPM sealing types are available; for other materials and further information contact our Sales Dpt.

2XP/2XM main dimensional data

Description example

Pump: 2XP-A-140-D-SAEA-B-N-30-0-U12U10

Motor: 2XM-A-140-R-SAEA-B-N-30-0-U12U10-DRENU6

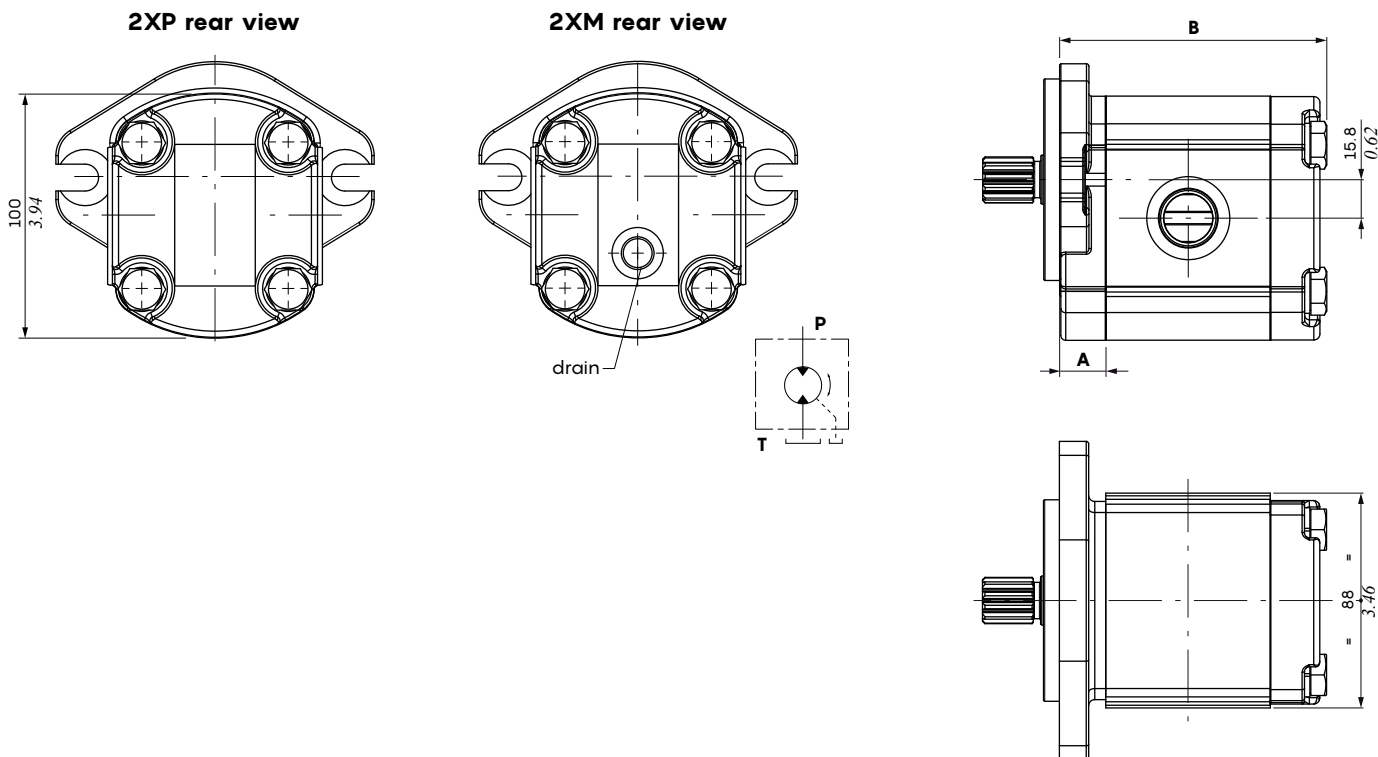

Flange type											
Dimension A											
EUR		SAEA		SAEB		B80		B50		E52	
mm	in	mm	in	mm	in	mm	in	mm	in	mm	in
19	0.75	19	0.75	20	0.79	21	0.83	18.8	0.74	16.3	0.92

Displacement	Dimension B											
	EUR		SAEA		SAEB		B80		B50		E52	
	mm	in	mm	in	mm	in	mm	in	mm	in	mm	in
040	93.1	3.67	93.1	3.67	94.1	3.70	95.1	3.74	92.9	3.66	90.4	3.56
060	96.4	3.80	96.4	3.80	97.4	3.83	98.4	3.87	96.2	3.79	93.7	3.69
080	100.6	3.96	100.6	3.96	101.6	4.00	102.6	4.04	100.4	3.95	97.9	3.85
110	104.7	4.12	104.7	4.12	105.7	4.16	106.7	4.20	104.5	4.11	102	4.02
140	109.7	4.32	109.7	4.32	110.7	4.36	111.7	4.40	109.5	4.31	107	4.21
160	113.9	4.48	113.9	4.48	114.9	4.52	115.9	4.56	113.7	4.48	111.2	4.38
190	118.9	4.68	118.9	4.68	119.9	4.72	120.9	4.76	118.7	4.67	116.2	4.57
220	123.9	4.88	123.9	4.88	124.9	4.92	125.9	4.96	123.7	4.87	121.5	4.78
260	129.7	5.11	129.7	5.11	130.7	5.15	131.7	5.19	129.5	5.10	127	5.00
290	133	5.24	133	5.24	134	5.28	135	5.31	51.8	2.04	130.3	5.13
310	138.1	5.44	138.1	5.44	139.1	5.48	140.1	5.52	137.9	5.43	135.4	5.33

Dimension B is referred to aluminum pump with standard aluminium rear cover (without ports).  
For flanges dimensions see related pages

## 2XPW/2XMW main dimensional data

### Description example

Pump: 2XPW-G-140-D-SAEA-B-N-30-0-U12U10

Motor: 2XMW-G-140-R-SAEA-B-N-30-0-U12U10-DRENU6

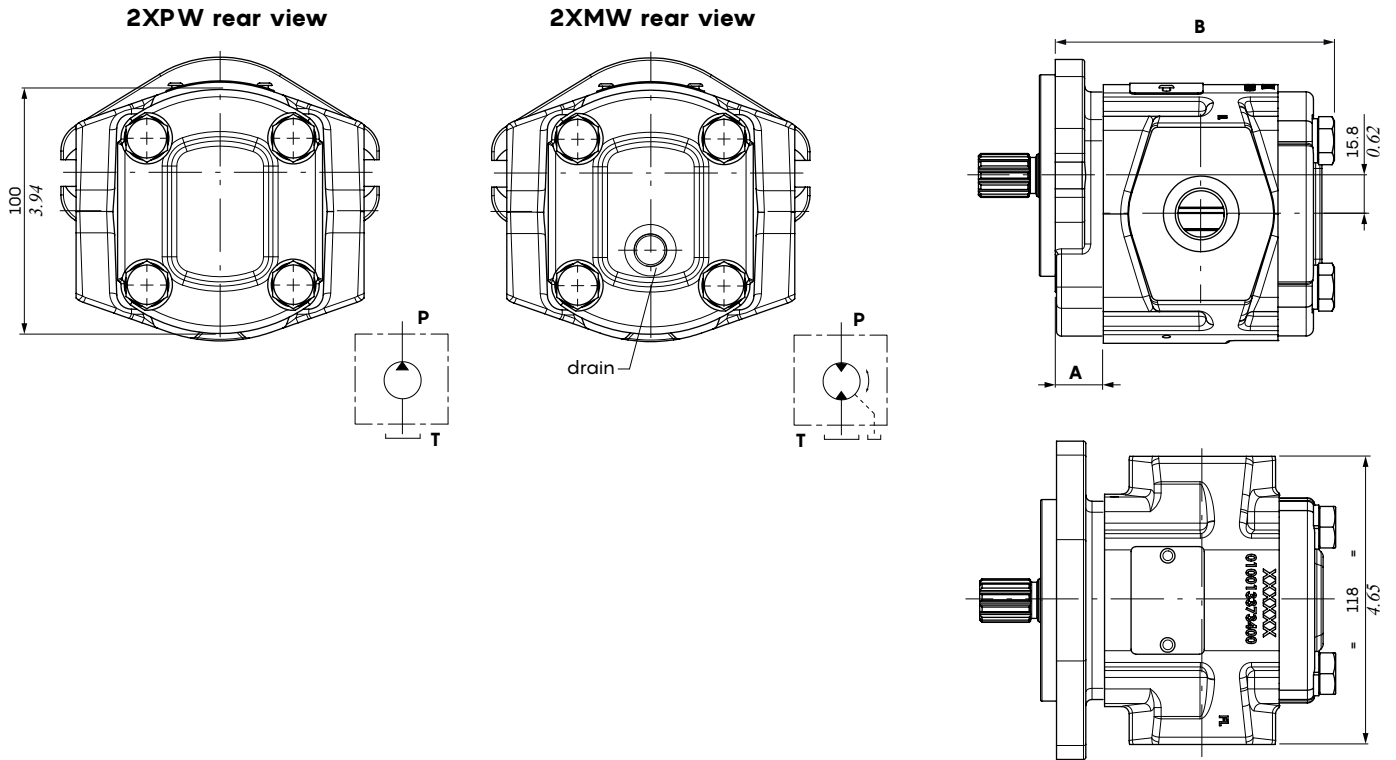

Flange type							
Dimension A							
EUR		SAEA		SAEB		B80	
mm	in	mm	in	mm	in	mm	in
19	0.75	19	0.75	20	0.79	21	0.83

Displacement	Dimension B							
	EUR		SAEA		SAEB		B80	
	mm	in	mm	in	mm	in	mm	in
110	104.5	4.11	104.5	4.11	105.5	4.15	106.5	4.19
140	109.5	4.31	109.5	4.31	110.5	4.35	111.5	4.39
160	113.7	4.48	113.7	4.48	114.7	4.52	115.7	4.56
190	118.7	4.67	118.7	4.67	119.7	4.71	120.7	4.75
220	123.7	4.87	123.7	4.87	124.7	4.91	125.7	4.99
260	129.5	5.10	129.5	5.10	130.5	5.14	131.5	5.18
290	132.8	5.23	132.8	5.23	133.8	5.27	133.8	5.27
310	137.9	5.43	137.9	5.43	138.9	5.47	139.9	5.51

Dimension B is referred to cast iron pump with standard cast iron rear cover (without ports).

For flanges dimensions see related pages

**Ports threading and connections**

**G (BSP) port threading**

Displ.	Side ports - Rear drain					
	2XP / 2XM			2XPW / 2XMW		
	IN	OUT	DRAIN	IN	OUT	DRAIN
040	G12	G12	G14	-	-	G14
060	G12	G12	G14	-	-	G14
080	G12	G12	G14	-	-	G14
110	G34	G12	G14	G34	G12	G14
140	G34	G12	G14	G34	G12	G14
160	G34	G12	G14	G34	G12	G14
190	G34	G12	G14	G34	G12	G14
220	G1	G12	G14	G1	G12	G14
260	G1	G12	G14	G1	G12	G14
290	G1	G12	G14	G1	G12	G14
310	G1	G12	G14	G1	G12	G14

	Thread dimension												
	A *	B		C (Ø)		D		IN		OUT		DRAIN	
		mm	in	mm	in	mm	in	Nm	lbft	Nm	lbft	Nm	lbft
G14	G 1/4"	13	0.51	21	0.83			-	-	-	-	15	11
G12	G 1/2"	16	0.63	31	1.22	0.5	0.020	20	15	50	37	-	-
G34	G 3/4"	18	0.71	36	1.48	0.5	0.020	30	22	90	666	-	-
G1	G 1"	20	0.79	45	1.77	0.5	0.020	50	37	130	96	-	-

(\*) threading according to ISO 228/1

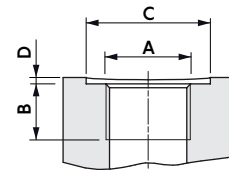

**U (UN-UNF) port threading**

Displ.	Side ports - Rear drain					
	2XP / 2XM			2XPW / 2XMW		
	IN	OUT	DRAIN	IN	OUT	DRAIN
040	U10	U10	U6	-	-	-
060	U10	U10	U6	-	-	-
080	U10	U10	U6	-	-	-
110	U12	U10	U6	U12	U10	U6
140	U12	U10	U6	U12	U10	U6
160	U12	U10	U6	U12	U10	U6
190	U12	U10	U6	U12	U10	U6
220	U16	U10	U6	U16	U10	U6
260	U16	U10	U6	U16	U10	U6
290	U16	U10	U6	U16	U10	U6
310	U16	U10	U6	U16	U10	U6

	Thread dimension												
	A *	B		C (Ø)		D		IN		OUT		DRAIN	
		mm	in	mm	in	mm	in	Nm	lbft	Nm	lbft	Nm	lbft
U6	9/16-18 (SAE6)	13	0.51	25	0.98	0.5	0.020	-	-	-	-	15	11
U10	7/8-14 (SAE10)	17	0.67	34	1.34	0.5	0.020	30	22	70	52	-	-
U12	1 1/16-12 (SAE12)	20	0.79	41	1.61	0.5	0.020	40	30	120	88	-	-
U16	1 5/16-12 (SAE16)	20	0.79	50	1.97	0.5	0.020	60	44	170	125	-	-

(\*) threading according to ISO 262 - ANSI B1.1

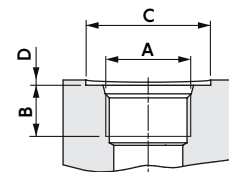

**T (GERMAN flange) port connection**

Displacement	Side ports - Rear drain					
	2XP / 2XM			2XPW / 2XMW		
	IN	OUT	DRAIN	IN	OUT	DRAIN
040	T20	T15	G14/U6	-	-	-
060	T20	T15	G14/U6	-	-	-
080	T20	T15	G14/U6	-	-	-
110	T20	T15	G14/U6	T20	T15	G14/U6
140	T20	T15	G14/U6	T20	T15	G14/U6
160	T20	T15	G14/U6	T20	T15	G14/U6
190	T20	T15	G14/U6	T20	T15	G14/U6
220	T20	T15	G14/U6	T20	T15	G14/U6
260	T20	T15	G14/U6	T20	T15	G14/U6
290	T20	T15	G14/U6	T20	T15	G14/U6
310	T20	T15	G14/U6	T20	T15	G14/U6

	Thread dimension										
	A (Ø)		B (Ø)		C	D		IN		OUT	
	mm	in	mm	in		mm	in	Nm	lbft	Nm	lbft
T15	15	0.59	35	1.31	M6	15	0.59	8	6	8	6
T20	20	0.79	40	1.57	M6	15	0.59	8	6	8	6

NOTE: for drain connection tightening torque see previous tables

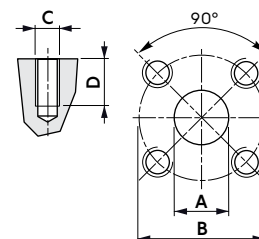

### Ports threading and connections

#### N (EUROPEAN flange) port connection

Displacement	Side ports - Rear drain					
	2XP / 2XM			2XPW / 2XMW		
	IN	OUT	DRAIN	IN	OUT	DRAIN
040	N13	N13	G14/U6	-	-	-
060	N13	N13	G14/U6	-	-	-
080	N13	N13	G14/U6	-	-	-
110	N19	N13	G14/U6	N19	N13	G14/U6
140	N19	N13	G14/U6	N19	N13	G14/U6
160	N19	N13	G14/U6	N19	N13	G14/U6
190	N19	N13	G14/U6	N19	N13	G14/U6
220	N19	N13	G14/U6	N19	N13	G14/U6
260	N19	N13	G14/U6	N19	N13	G14/U6
290	N19	N13	G14/U6	N19	N13	G14/U6
310	N19	N13	G14/U6	N19	N13	G14/U6

	Thread dimension										
	A (Ø)		B (Ø)		C	D		IN		OUT	
	mm	in	mm	in		mm	in	Nm	lbft	Nm	lbft
N13	13	0.51	30	1.18	M6	15	0.59	8	6	8	6
N19	19	0.75	40	1.57	M8	15	0.59	15	11	15	11

NOTE: for drain connection tightening torque see previous tables

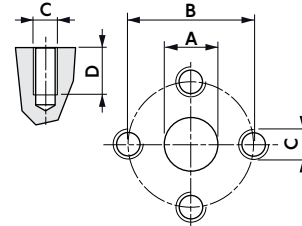

#### F (proprietary flange) port connection

Displacement	Side ports - Rear drain					
	2XP / 2XM			2XPW / 2XMW		
	IN	OUT	DRAIN	IN	OUT	DRAIN
040	F20	F15	G14/U6	-	-	-
060	F20	F15	G14/U6	-	-	-
080	F20	F15	G14/U6	-	-	-
110	F20	F15	G14/U6	F20	F15	G14/U6
140	F26	F15	G14/U6	F26	F15	G14/U6
160	F26	F15	G14/U6	F26	F15	G14/U6
190	F26	F15	G14/U6	F26	F15	G14/U6
220	F26	F15	G14/U6	F26	F15	G14/U6
260	F26	F15	G14/U6	F26	F15	G14/U6
290	F26	F15	G14/U6	F26	F15	G14/U6
310	F26	F15	G14/U6	F26	F15	G14/U6

	Thread dimension												
	A (Ø)		B		C		D	E		IN		OUT	
	mm	in	mm	in	mm	in		mm	in	Nm	lbft	Nm	lbft
F15	15	0.51	17.4	0.69	38	1.50	M6	15	0.59	8	6	8	6
F20	20	0.79	17.4	0.69	38	1.50	M6	15	0.59	8	6	8	6
F26	26	1.02	22.4	0.88	47.6	1.87	M6	15	0.59	8	6	8	6

NOTE: for drain connection tightening torque see previous tables

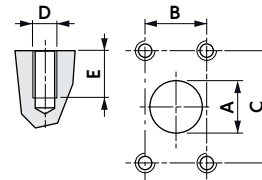

#### FM\*\* port connection: dimensions according to SAE J518-1 / ISO 6162-1

Port connection FU with UN-UNF screws are available on request

Displacement	Side ports - Rear drain					
	2XP / 2XM			2XPW / 2XMW		
	IN*	OUT*	DRAIN	IN	OUT	DRAIN
040	FM34	FM12	G14/U6	-	-	-
060	FM34	FM12	G14/U6	-	-	-
080	FM34	FM12	G14/U6	-	-	-
110	FM34	FM12	G14/U6	FM34	FM13	G14/U6
140	FM1	FM12	G14/U6	FM1	FM13	G14/U6
160	FM1	FM12	G14/U6	FM1	FM13	G14/U6
190	FM1	FM12	G14/U6	FM1	FM13	G14/U6
220	FM1	FM12	G14/U6	FM1	FM13	G14/U6
260	FM1	FM12	G14/U6	FM1	FM13	G14/U6
290	FM1	FM12	G14/U6	FM1	FM13	G14/U6
310	FM1	FM12	G14/U6	FM1	FM13	G14/U6

	Thread dimension												
	A (Ø)		B		C		D	E		IN		OUT	
	mm	in	mm	in	mm	in		mm	in	Nm	lbft	Nm	lbft
*FM13	13	0.51	17.5	0.69	38.1	1.5	M8	14	0.55	15	11	15	11
*FM19	19	0.75	22.3	0.88	47.6	1.87	M10	18	0.71	20	15	20	15
*FM25	25	0.98	26.2	1.03	52.4	2.06	M10	16	0.63	20	15	25	18

NOTES: for drain connection tightening torque see previous tables.

(\*) description is referred to pipe diameter

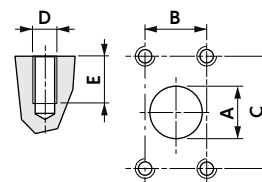

Description composition

With standard shafts and flanges

	1A	6	5B	4		1A	2A		3A		5A	5B	6A	6B						
			5A	3A									Suction port	Delivery port						
	2XP	-	A	-	140	-	D	-	EUR	-	B	-	N	-	12	-	0	-	G34	G12
<b>Pump/Motor type</b>	<b>Displacement</b>		<b>Flange Type</b>		<b>O-ring seals</b>		<b>Connection position</b>													
2XP: aluminium pump 2XM: aluminium motor 2XPW: cast iron pump 2XMW: cast iron motor	040 - 060 - 080 - 110 140 - 160 - 190 - 220 260 - 290 - 310		SAEA - SAEB <sup>(1)</sup> - EUR B80 - B50 <sup>(2)</sup> - E52 <sup>(2)</sup> NOTES: (1) only cast iron (2) only aluminium		N: NBR V: FPM		0: side ports 1: left side and rear ports 3: right side and rear ports 4: rear ports													
<b>Flange and cover material</b>	<b>Rotation direction</b>		<b>Shaft O-ring seals</b>		<b>Shaft type</b>		<b>Connection type</b>													
A: aluminium flange and cover AG: aluminium flange/cast iron cover GA: cast iron flange/aluminium cover G: cast iron flange and cover	D: clockwise rotation S: counter-clockwise rotation R: reversible X: reversible with internal drain, please contact Sales Department		A: without O-ring seals B: for pressure up to 3 bar - 43.5 psi H: for pressure up to 8 bar - 116 psi K: for pressure up to 30 bar - 435 psi		10: tapered 1:8 11: tapered 1:5 12: EUR parallel shaft 13: SAEA parallel shaft 14: SAEA 9T splined 15: DIN5482 9T splined 17: dihedral claw 30: SAE 11T splined 31: SAE 3/4" parallel shaft 32: SAE 3/4" (SHORT) parallel shaft 40: SAE 10T splined		G: BSP threading U: UN-UNF threading N: european flange T: german flange F: proprietary flanging FM: SAE J518-1 flange NOTE: For ports dimensions see previous pages													

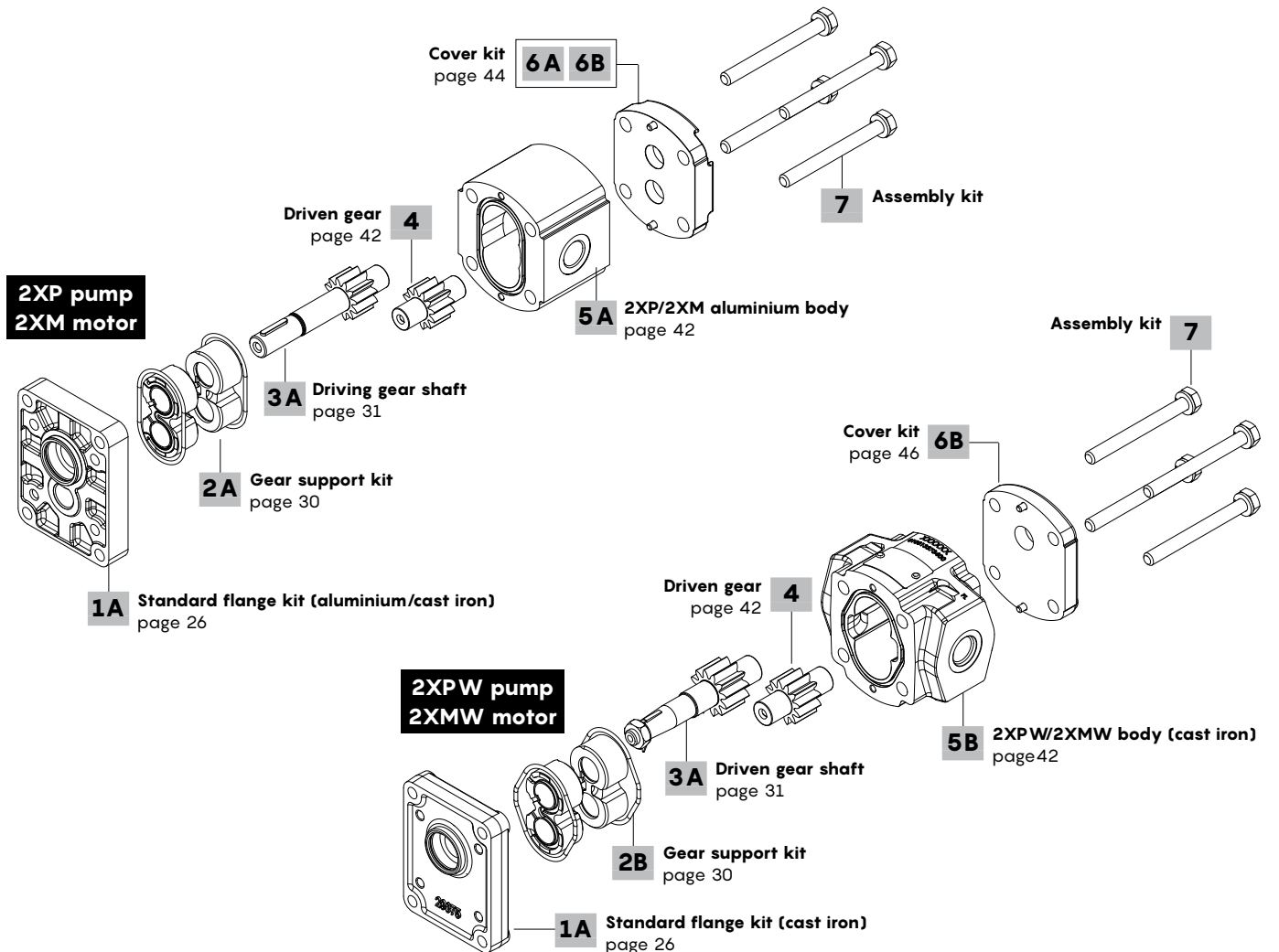

## Description composition

With Ø22 shaft and flange

	1C	6	5B	4	5A	3C		1C	2C		3C		5A	5B	6A	6B				
													Suction port		Delivery port					
	2XP	-	G	-	140	-	D	-	SAEB	-	B	-	N	-	45	-	0	-	T20	T20
<b>Pump/Motor type</b>	<b>Displacement</b>		<b>Flange Type</b>		<b>O-ring seals</b>		<b>Connection position</b>													
2XP: aluminium pump 2XM: aluminium motor 2XPW: cast iron pump 2XMW: cast iron motor	040 - 060 - 080 - 110 <b>140</b> - 160 - 190 - 220 260 - 290 - 310		SAEB <sup>(1)</sup> NOTES: (1) only cast iron		N: NBR V: FPM		0: side ports 1: left side and rear ports 3: right side and rear ports 4: rear ports													
<b>Flange and cover material</b>	<b>Rotation direction</b>		<b>Shaft O-ring seals</b>		<b>Shaft type</b>		<b>Connection type</b>													
G: cast iron flange and cover GA: cast iron flange/aluminium cover	D: clockwise rotation S: counter-clockwise rotation		A: whitout O-ring seals <b>B: for pressure up to 3 bar - 43.5 psi</b> H: for pressure up to 8 bar - 116 psi K: for pressure up to 30 bar - 435 psi		45: SAEB 13T splined		G: BSP threading U: UN-UNF threading N: european flange <b>T: german flange</b> F: proprietary flanging FM: SAE J518-1 flange <b>NOTE:</b> For ports dimensions see previous pages													

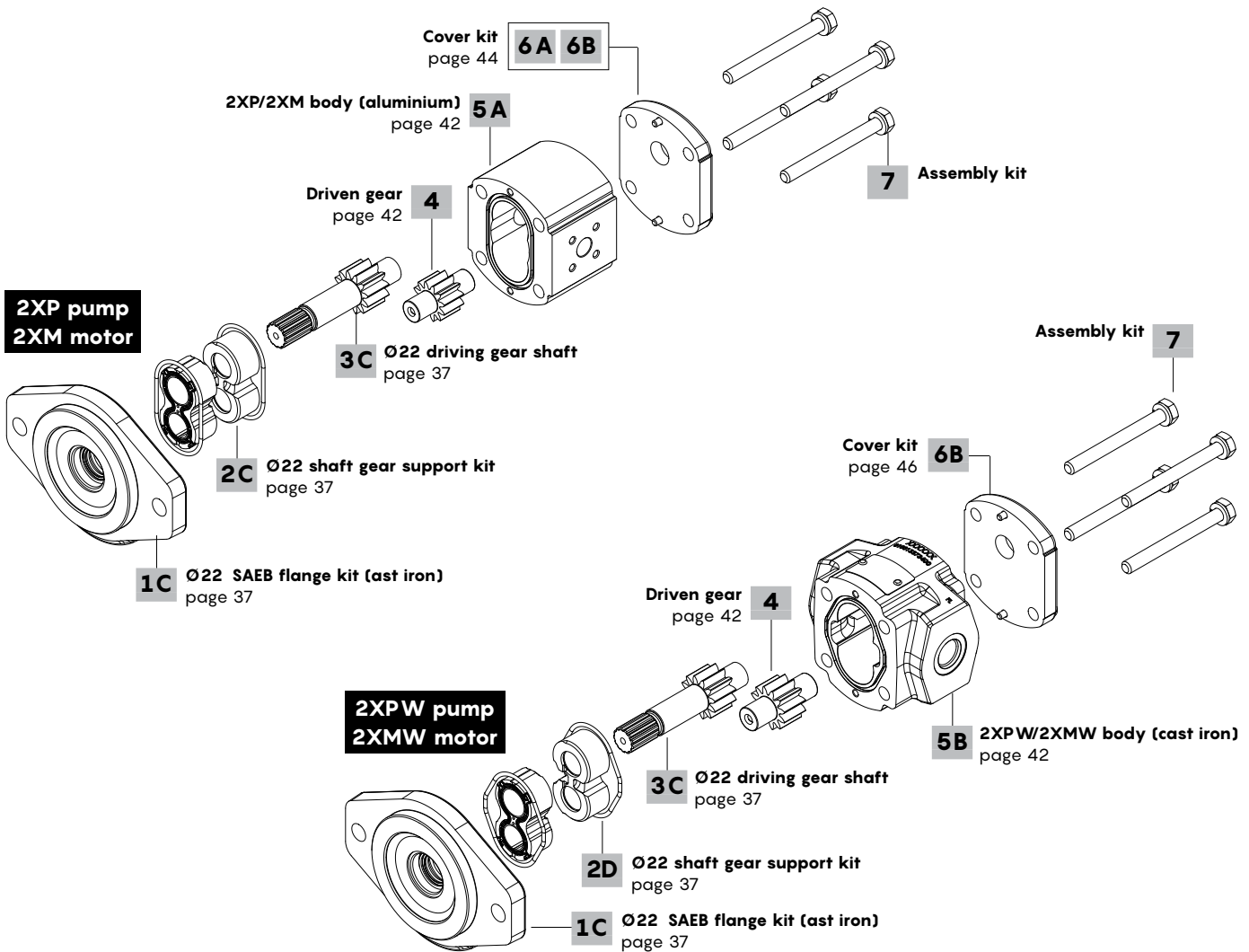



**Description composition**

**Flange kit with outboard bearing (SUP version)**

	<b>1B</b>	<b>6</b>	<b>5B</b>	<b>4</b>	<b>5A</b>	<b>3B</b>	<b>1B</b>	<b>2A</b>	<b>1B</b>	<b>5A</b>	<b>5B</b>	<b>6A</b>	<b>6B</b>
										Suction port		Delivery port	
	<b>2XM</b>	<b>-</b>	<b>A</b>	<b>-</b>	<b>140</b>	<b>-</b>	<b>R</b>	<b>-</b>	<b>SUPEUR</b>	<b>-</b>	<b>H</b>	<b>-</b>	<b>N</b>
		<b>-</b>				<b>-</b>				<b>-</b>			<b>10</b>
													<b>0</b>
													<b>G12</b>
													<b>G12</b>
<b>Pump/Motor type</b>	<b>Displacement</b>			<b>Flange Type <sup>(1)</sup></b>			<b>O-ring seals</b>			<b>Connection position</b>			
<b>2XP: aluminium pump</b>	040 - 060 - 080 - 110			SUPSAEA - SUPEUR			N: NBR			<b>0: side ports</b>			
<b>2XM: aluminium motor</b>	140 - 160 - 190 - 220			SUPB80 - SUPB50			V: FPM			1: left side and rear ports			
<b>2XPW: cast iron pump</b>	260 - 290 - 310			<b>NOTES:</b>						3: right side and rear ports			
<b>2XMW: cast iron motor</b>				<i>(1) only aluminium</i>						4: rear ports			
<b>Flange and cover material</b>	<b>Rotation direction</b>			<b>Shaft O-ring seals</b>			<b>Shaft type</b>			<b>Connection type</b>			
<b>A: aluminium</b>	<b>D: clockwise rotation</b>			<b>A: whitout O-ring seals</b>			<b>10: tapered 1:8</b>			<b>G: BSP threading</b>			
	<b>S: counter-clockwise rotation</b>			<b>B: for pressure up to 3 bar - 43.5 psi</b>			<b>11: tapered 1:5</b>			<b>U: UN-UNF threading</b>			
	<b>R: reversible</b>			<b>H: for pressure up to 8 bar - 116 psi</b>			<b>30: SAE 11T splined</b>			<b>N: european flange</b>			
	<b>X: reversible with internal drain, please contact Sales Department</b>			<b>K: for pressure up to 30 bar - 435 psi</b>			<b>31: SAE 3/4" parallel</b>			<b>T: german flange</b>			
							<b>32: SAE 3/4" (SHORT)</b>			<b>F: proprietary flanging</b>			
							<b>46: parallel Ø18</b>			<b>FM: SAE J518-1 flange</b>			
							<b>47: parallel Ø22</b>			<b>NOTE:</b>			
							<b>48: parallel Ø22 (LONG)</b>			For ports dimensions see previous pages			
							<b>51: conical 1:5</b>						

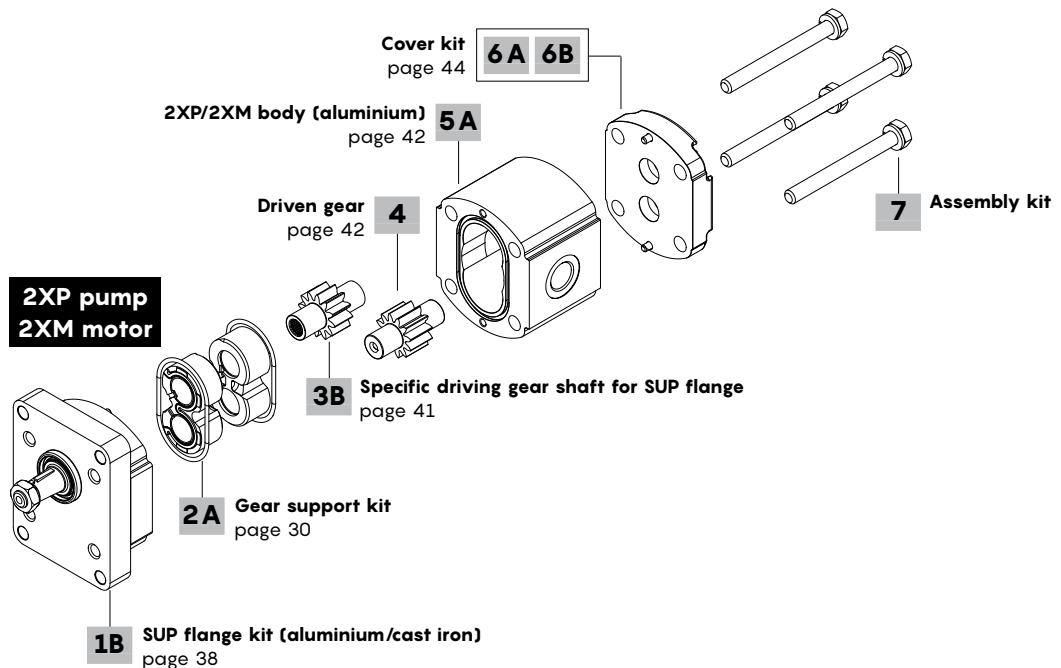

*NOTE: SUP type flanges are combined with spacer and driving gear shaft*

## Standard flange kits

### SAEA flange: aluminium and cast iron types

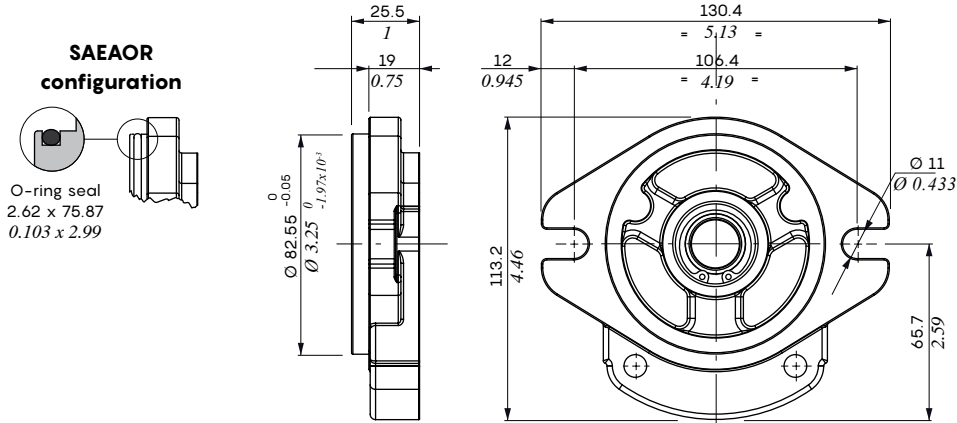

#### Aluminium type

Ordering codes						
Seals material	SAEA flange kit Ø18 mm (0.709 in) shaft seal ring			SAEAOR flange kit Ø18 mm (0.709 in) shaft seal ring		
	B	H	K	B	H	K
		up to 3 bar (43.5 psi)	up to 8 bar (116 psi)	up to 30 bar (435 psi)	up to 3 bar (43.5 psi)	up to 8 bar (116 psi)
<b>NBR</b>	<b>N</b> 5GKFX2P001	5GKFX20001	5GKFX20012	5GKFXP0002	5GKFX2002	5GKFX20013
<b>FPM</b>	<b>V</b> 5GKFX2P001V	5GKFX20001V	5GKFX20012V	5GKFXP0002V	5GKFX2002V	5GKFX20013V

Flanges are compatible with Ø18 mm (0.709 in) shaft type: see pages from 31 to 36

Seals material	SAEA flange kit Ø20 mm (0.787 in) shaft seal ring			SAEAOR flange kit Ø20 mm (0.787 in) shaft seal ring		
	B	H	K	B	H	K
		up to 3 bar (43.5 psi)	up to 8 bar (116 psi)	up to 30 bar (435 psi)	up to 3 bar (43.5 psi)	up to 8 bar (116 psi)
<b>NBR</b>	<b>N</b> 5GKFX2P013	-	5GKFX20034	5GKFX2P017	-	5GKFX20053
<b>FPM</b>	<b>V</b> 5GKFX2P013V	-	5GKFX20034V	5GKFX2P017V	-	5GKFX20053V

Flanges are compatible with Ø20 mm (0.787 in) shaft type: see pages from 31 to 36

#### Cast iron type

Ordering codes						
Seals material	SAEA flange kit Ø18 mm (0.709 in) shaft seal ring			SAEAOR flange kit Ø18 mm (0.709 in) shaft seal ring		
	B	H	K	B	H	K
		up to 3 bar (43.5 psi)	up to 8 bar (116 psi)	up to 30 bar (435 psi)	up to 3 bar (43.5 psi)	up to 8 bar (116 psi)
<b>NBR</b>	<b>N</b> 5GKFX2P008	5GKFX20025	5GKFX20027	5GKFX2P009	5GKFX20026	5GKFX20028
<b>FPM</b>	<b>V</b> 5GKFX2P008V	5GKFX20025V	5GKFX20027V	5GKFX2P009V	5GKFX20026V	5GKFX20028V

Flanges are compatible with Ø18 mm (0.709 in) shaft type: see pages from 31 to 36

Seals material	SAEA flange kit Ø20 mm (0.787 in) shaft seal ring		
	B	H	K
		up to 3 bar (43.5 psi)	up to 8 bar (116 psi)
<b>NBR</b>	<b>N</b> 5GKFX2P011	-	5GKFX20051
<b>FPM</b>	<b>V</b> 5GKFX2P011V	-	5GKFX20051V

Flanges are compatible with Ø20 mm (0.787 in) shaft type: see pages from 31 to 36

### SAEB flange: cast iron type

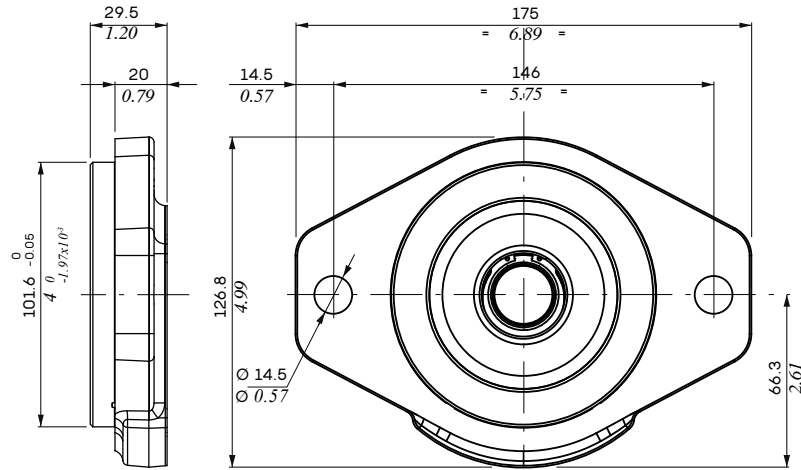

Ordering codes				
Seals material	Ø18x30 mm (0.709x1.18 in) shaft seal ring B		Ø20x30 mm (0.787x1.18 in) shaft seal ring B	
	up to 3 bar (43.5 psi)		up to 3 bar (43.5 psi)	
NBR	N	5GKFX2P024	5GKFX2P023	
FPM	V	5GKFX2P024V	5GKFX2P023V	

Flanges are compatible with Ø18 mm (0.709 in) shaft type: see pages 31 to 36

Flanges are compatible with Ø20 mm (0.787 in) shaft type: see pages 31 to 36

### EUR flange: aluminium and cast iron types

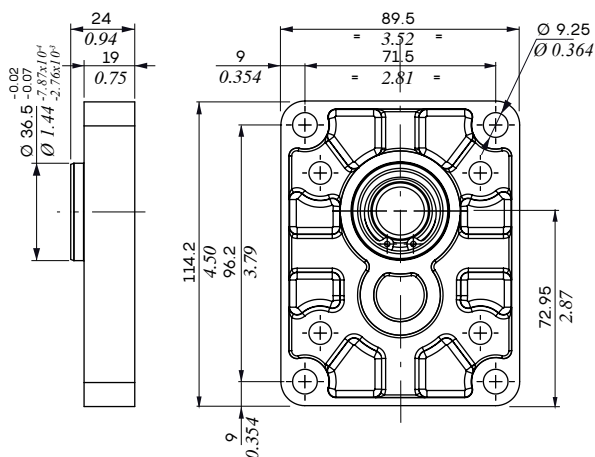

#### Aluminium type

Ordering codes					
Seals material	Ø18 mm (0.709 in) shaft seal ring				
	B	H	K		
		up to 3 bar (43.5 psi)	up to 8 bar (116 psi)	up to 30 bar (435 psi)	
NBR	N	5GKFX2P000	5GKFX20000	5GKFX20011	
FPM	V	5GKFX2P000V	5GKFX20000V	5GKFX20011V	

Flanges are compatible with Ø18 mm (0.709 in) shaft type: see pages 31 to 36

#### Cast iron type

Ordering codes					
Seals material	Ø18 mm (0.709 in) shaft seal ring				
	B	H	K		
		up to 3 bar (43.5 psi)	up to 8 bar (116 psi)	up to 30 bar (435 psi)	
NBR	N	5GKFX2P007	5GKFX20024	5GKFX20023	
FPM	V	5GKFX2P007V	5GKFX20024V	5GKFX20023V	

Flanges are compatible with Ø18 mm (0.709 in) shaft type: see pages 31 to 36

## Standard flanges kits

### B80 flange: aluminium and cast iron types

#### Aluminium type dimensions

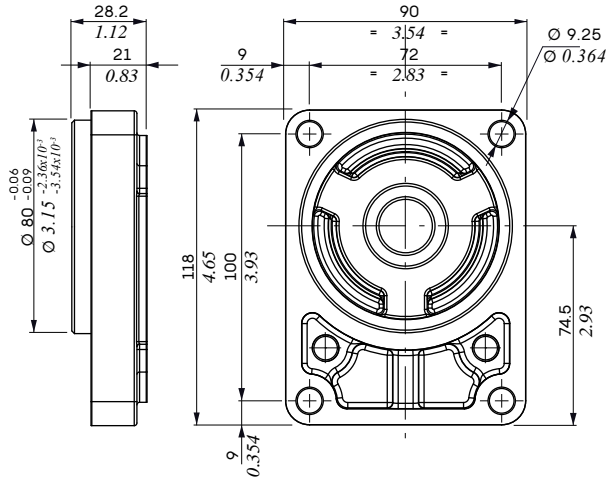

Ordering codes			
$\varnothing 18$ mm (0.709 in) shaft seal ring			
Seals material	$\varnothing 18$ mm (0.709 in) shaft seal ring		
	B	H	K
	up to 3 bar (43.5 psi)	up to 8 bar (116 psi)	up to 30 bar (435 psi)
NBR	N	5GKFX2P003	5GKFX20014
FPM	V	5GKFX2P003V	5GKFX20014V

Flanges are compatible with  $\varnothing 18$  mm (0.709 in) shaft type: see pages 31 to 36

#### Cast iron type dimensions

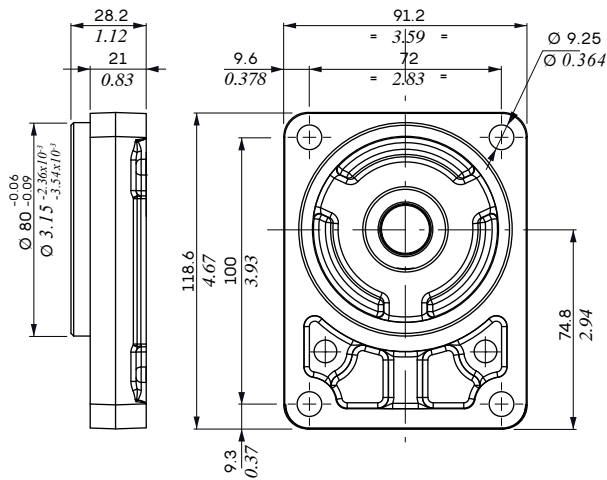

Ordering codes			
$\varnothing 18$ mm (0.709 in) shaft seal ring			
Seals material	$\varnothing 18$ mm (0.709 in) shaft seal ring		
	B	H	K
	up to 3 bar (43.5 psi)	up to 8 bar (116 psi)	up to 30 bar (435 psi)
NBR	N	5GKFX2P021	5GKFX20046
FPM	V	5GKFX2P021V	5GKFX20046V

Flanges are compatible with  $\varnothing 18$  mm (0.709 in) shaft type: see pages 31 to 36

**B50 flange: aluminium type**

**B50CX configuration**

**B50CY configuration**

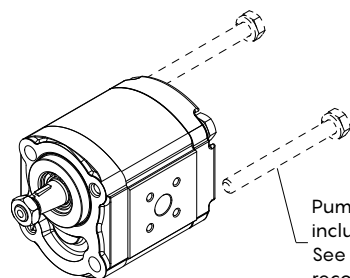
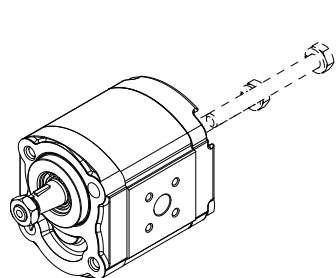
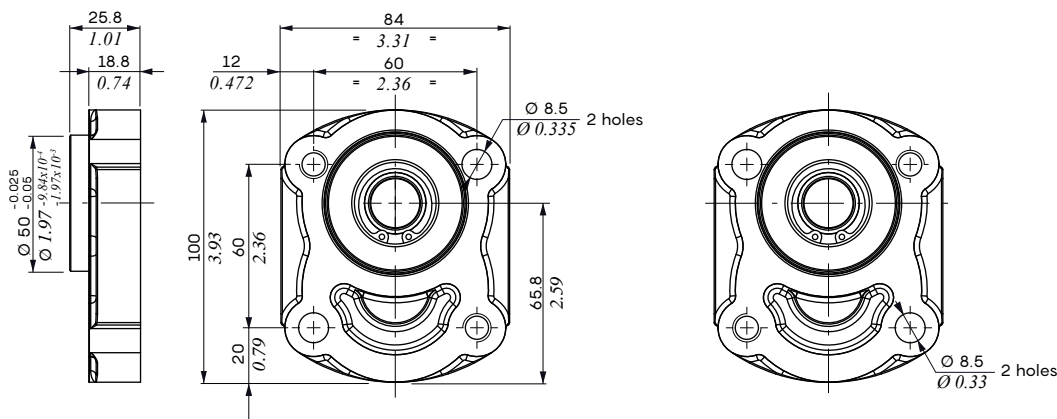

Pump fixing bolts are not included. See table for minimum recommended length.

Ordering codes						
Seals material	B50CX flange kit			B50CY flange kit		
	Ø18 mm (0.709 in) shaft seal ring			Ø18 mm (0.709 in) shaft seal ring		
	B	H	K	B	H	K
	up to 3 bar (43.5 psi)	up to 8 bar (116 psi)	up to 30 bar (435 psi)	up to 3 bar (43.5 psi)	up to 8 bar (116 psi)	up to 30 bar (435 psi)
<b>NBR</b>	<b>N</b> 5GKFX2P004	5GKFX20004	5GKFX20015	5GKFX2P006	5GKFX20031	5GKFX20021
<b>FPM</b>	<b>V</b> 5GKFX2P004V	5GKFX20004V	5GKFX20015V	5GKFX2P006V	5GKFX20031V	5GKFX20021V

Flanges are compatible with Ø18 mm (0.709 in) shaft type: see pages from 31 to 36

Fixing bolts	
Displacement	Min. recommended length
<b>040</b>	105 (4.13)
<b>060</b>	105 (4.13)
<b>080</b>	110(4.33)
<b>110</b>	115 (4.53)
<b>140</b>	120 (4.72)
<b>160</b>	125 (4.92)
<b>190</b>	130 (5.12)
<b>220</b>	135 (5.32)
<b>260</b>	140 (5.51)
<b>290</b>	145 (5.71)
<b>310</b>	150 (5.91)

## Standard flange kits

### E52 flange: aluminium type

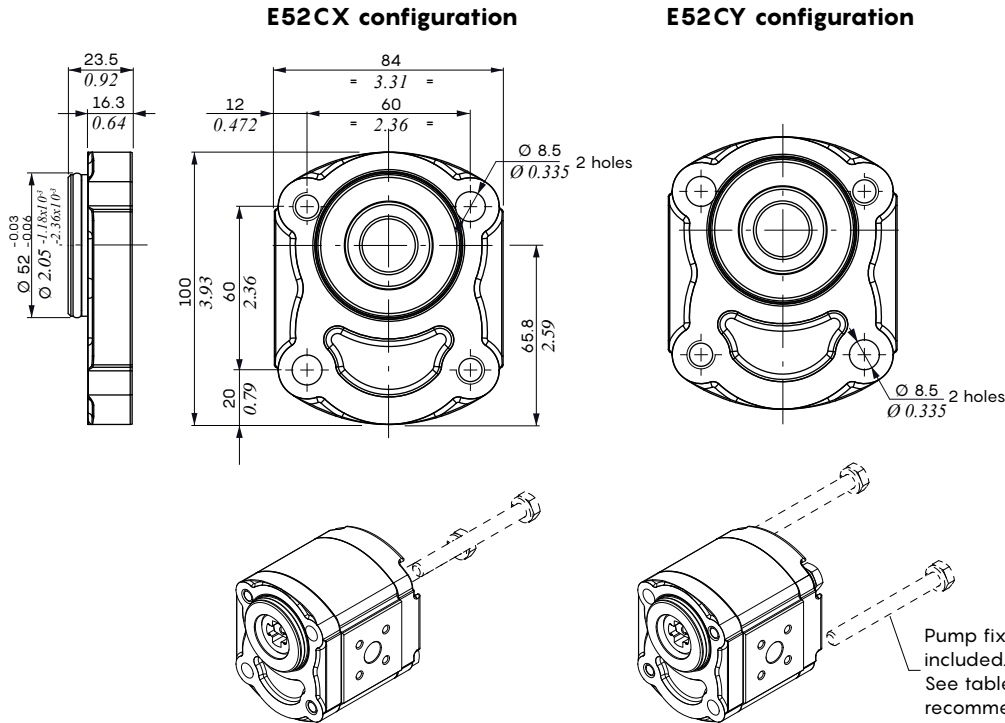

Fixing bolts	
Displacement	Min. recommended length
040	100 (3.94)
060	105 (4.13)
080	110 (4.33)
110	115 (4.53)
140	120 (4.72)
160	120 (4.72)
190	125 (4.92)
220	130 (5.12)
260	140 (5.51)
290	140 (5.51)
310	145 (5.71)

Pump fixing bolts are not included.  
See table for minimum recommended length.

Ordering codes			
Seals material		E52CX flange kit	E52CY flange kit
		Ø18 mm (0.709 in) shaft seal ring	Ø18 mm (0.709 in) shaft seal ring
		A	A
		without shaft seal	without shaft seal
NBR	N	5GKFX20005	5GKFX20030
FPM	V	5GKFX20005V	5GKFX20030V

Flanges are compatible only with **17 type** shaft type: see page 34

## Gear support kits



Seals material	2XP/2XM aluminium ordering codes				2XPW/2XMW cast iron ordering codes		
	For standard body		For LAU-MU-SGR special bodies (page 43)		Pumps and Unidir. motors	Reversible motors	
		Pumps and Unidir. motors	Reversible motors	Pumps and Unidir. motors	Reversible motors		
NBR	N	5GKS20028	5GKS20035	5GKS20027	5GKS20038	5GKS20027	5GKS20038
FPM	V	5GKS20029	5GKS20036	5GKS20030	5GKS20039	5GKS20030	5GKS20039

**Type 10: conical 1:8 shaft**

**Ø18 mm (0.71 in) seal**

Flange	Shaft dimension			
	A		B	
	mm	in	mm	in
SAEA	39.5	1.56	27.5	1.08
EUR	39.5	1.56	27.5	1.08
B80C	37.5	1.48	25.5	1.00
SAEB Ø18	38.5	1.51	26.5	1.04

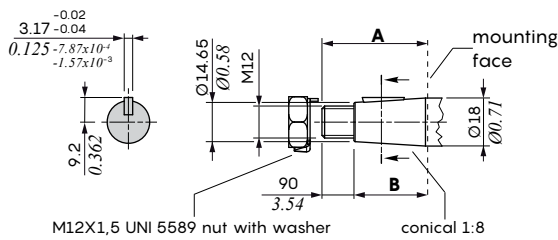

Max transmitted torque = 140 Nm - 103 lbft  
Tightening torque (M12x1.5) = 60 Nm - 44 lbft

Driving gear shaft kit	
Displacement	Ordering codes
040	5GKI2X0002*
060	5GKI2X0003*
080	5GKI2X0004*
110	5GKI2X0005
140	5GKI2X0000
160	5GKI2X0006
190	5GKI2X0007
220	5GKI2X0008
260	5GKI2X0009
290	5GKI2X0011
310	5GKI2X0010

(\* ) only for 2XP/2XM

**Type 11: conical 1:5 shaft**

**Ø18 mm (0.71 in) seal**

Flange	Shaft dimension			
	A		B	
	mm	in	mm	in
SAEA	39.5	1.56	27.5	1.08
EUR	39.5	1.56	27.5	1.08
B80C	37.5	1.48	25.5	1.00
B50	39.5	1.56	27.5	1.08
SAEB Ø18	38.5	1.51	26.5	1.04

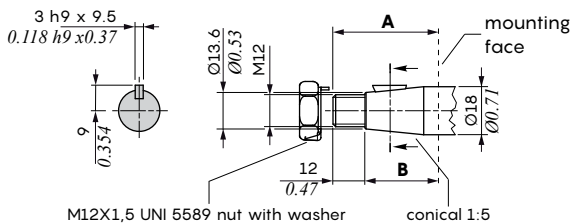

Max transmitted torque = 140 Nm - 103 lbft  
Tightening torque (M12x1.5) = 60 Nm - 44 lbft

Driving gear shaft kit	
Displacement	Ordering codes
040	5GKI2X0022*
060	5GKI2X0023*
080	5GKI2X0024*
110	5GKI2X0025
140	5GKI2X0026
160	5GKI2X0027
190	5GKI2X0028
220	5GKI2X0029
260	5GKI2X0030
290	5GKI2X0031
310	5GKI2X0032

(\* ) only for 2XP/2XM

## Driving gear shafts

### Type 12: EUR parallel shaft

**Ø18 mm (0.71 in) seal**

Flange	Shaft dimension			
	A		B	
	mm	in	mm	in
SAEA	36.5	1.44	30	1.18
EUR	36.5	1.44	30	1.18
B80C	34.5	1.36	30	1.18
SAEB Ø18	35.5	1.4	30	1.18

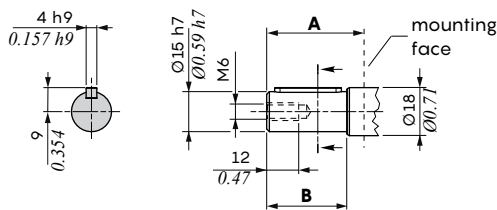

Max transmitted torque = 80 Nm - 59 lbft

Driving gear shaft kit	
Displacement	Ordering codes
040	5GKI2X0033*
060	5GKI2X0034*
080	5GKI2X0035*
110	5GKI2X0036
140	5GKI2X0037
160	5GKI2X0038
190	5GKI2X0039
220	5GKI2X0040
260	5GKI2X0041
290	5GKI2X0042
310	5GKI2X0043

(\* ) only for 2XP/2XM

### Type 13: SAEA parallel shaft

**Ø18 mm (0.71 in) seal**

Flange	Shaft dimension			
	A		B	
	mm	in	mm	in
SAEA	36.5	1.44	30	1.18
EUR	36.5	1.44	30	1.18
B80C	34.5	1.36	30	1.18
SAEB Ø18	35.5	1.4	30	1.18

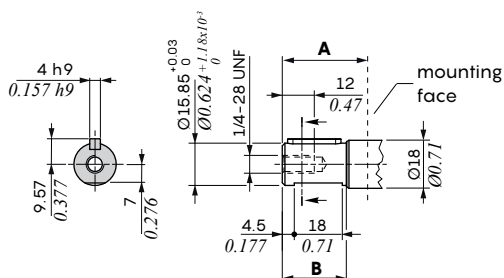

Max transmitted torque = 90 Nm - 66 lbft

Driving gear shaft kit	
Displacement	Ordering codes
040	5GKI2X0044*
060	5GKI2X0045*
080	5GKI2X0046*
110	5GKI2X0047
140	5GKI2X0048
160	5GKI2X0049
190	5GKI2X0050
220	5GKI2X0051
260	5GKI2X0052
290	5GKI2X0053
310	5GKI2X0054

(\* ) only for 2XP/2XM



**Type 14: 9T splined shaft**

**Ø18 mm (0.71 in) seal**

Flange	Shaft dimension			
	A		B	
	mm	in	mm	in
<b>SAEA</b>	31.5	1.24	23	0.91
<b>EUR</b>	31.5	1.24	23	0.91
<b>B80C</b>	29.5	1.16	23	0.91
<b>SAEB Ø18</b>	30.5	1.2	23	0.91

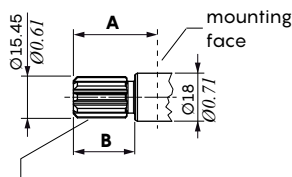

splined profile: SAEA 9T - 16/32 DP

Driving gear shaft kit	
Displacement	Ordering codes
<b>040</b>	5GKI2X0019*
<b>060</b>	5GKI2X0020*
<b>080</b>	5GKI2X0021*
<b>110</b>	5GKI2X0012
<b>140</b>	5GKI2X0013
<b>160</b>	5GKI2X0014
<b>190</b>	5GKI2X0015
<b>220</b>	5GKI2X0001
<b>260</b>	5GKI2X0016
<b>290</b>	5GKI2X0017
<b>310</b>	5GKI2X0018

(\*) only for 2XP/2XM

Max transmitted torque = 100 Nm - 74 lbft

**Type 15: DIN5482 17x14 9T splined shaft**

**Ø18 mm (0.71 in) seal**

Flange	Shaft dimension			
	A		B	
	mm	in	mm	in
<b>SAEA</b>	26	1.02	20	0.79
<b>EUR</b>	26	1.02	20	0.79
<b>B80C</b>	24	0.94	20	0.79
<b>SAEB Ø18</b>	25	0.98	20	0.79

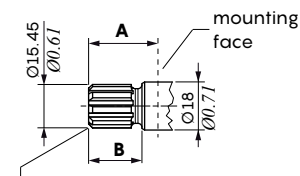

splined profile: B 17x14 DIN 5482 -9 teeth

Driving gear shaft kit	
Displacement	Ordering codes
<b>040</b>	5GKI2X0055*
<b>060</b>	5GKI2X0056*
<b>080</b>	5GKI2X0057*
<b>110</b>	5GKI2X0058
<b>140</b>	5GKI2X0059
<b>160</b>	5GKI2X0060
<b>190</b>	5GKI2X0061
<b>220</b>	5GKI2X0062
<b>260</b>	5GKI2X0063
<b>290</b>	5GKI2X0064
<b>310</b>	5GKI2X0065

(\*) only for 2XP/2XM

Max transmitted torque = 100 Nm - 74 lbft

## Driving gear shafts

### Type 17: dihedral crow shaft

**Ø18 mm (0.71 in) seal**

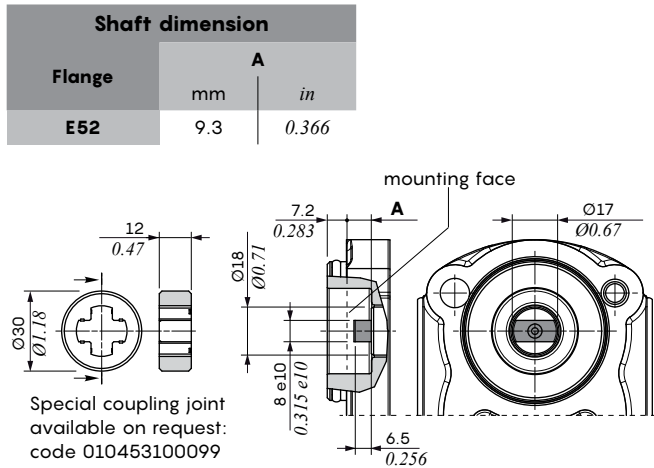

Driving gear shaft kit	
Displacement	Ordering codes
040	5GKI2X0154*
060	5GKI2X0155*
080	5GKI2X0156*
110	5GKI2X0157
140	5GKI2X0158
160	5GKI2X0159
190	5GKI2X0160
220	5GKI2X0161
260	5GKI2X0162
290	5GKI2X0163
310	5GKI2X0164

(\* ) only for 2XP/2XM

Max transmitted torque = 80 Nm - 59 lbf<sub>t</sub>

### Type 30: SAE 11T 16/32 splined shaft

**Ø20 mm (0.79 in) seal**

Flange	Shaft dimension			
	A		B	
	mm	in	mm	in
SAEA	31.5	1.24	23.8	0.94
SAEB Ø20	30.5	1.2	23.8	0.94

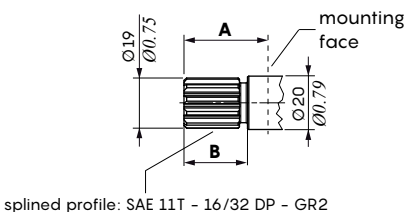

Driving gear shaft kit	
Displacement	Ordering codes
040	5GKI2X0099*
060	5GKI2X0100*
080	5GKI2X0101*
110	5GKI2X0102
140	5GKI2X0103
160	5GKI2X0104
190	5GKI2X0105
220	5GKI2X0106
260	5GKI2X0107
290	5GKI2X0108
310	5GKI2X0109

(\* ) only for 2XP/2XM

Max transmitted torque = 180 Nm - 133 lbf<sub>t</sub>

**Type 31: 4.76 key SAE parallel shaft**

**Ø20 mm (0.79 in) seal**

Flange	Shaft dimension			
	A		B	
	mm	in	mm	in
SAEA	53.8	2.12	44.5	1.75
SAEB Ø20	52.8	2.08	44.5	1.75

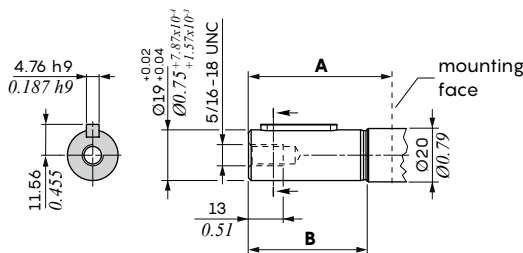

Driving gear shaft kit	
Displacement	Ordering codes
040	5GKI2X0110*
060	5GKI2X0111*
080	5GKI2X0112*
110	5GKI2X0113
140	5GKI2X0114
160	5GKI2X0115
190	5GKI2X0116
220	5GKI2X0117
260	5GKI2X0118
290	5GKI2X0119
310	5GKI2X0120

(\*) only for 2XP/2XM

Max transmitted torque = 140 Nm - 103 lbf<sub>t</sub>

**Type 32: 4.76 key SAE parallel shaft, short version**

**Ø20 mm (0.79 in) seal**

Flange	Shaft dimension			
	A		B	
	mm	in	mm	in
SAEA	31	1.22	24	0.94
SAEB Ø20	30	1.18	24	0.94

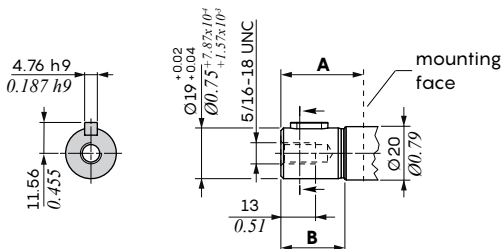

Driving gear shaft kit	
Displacement	Ordering codes
040	5GKI2X0121*
060	5GKI2X0122*
080	5GKI2X0123*
110	5GKI2X0124
140	5GKI2X0125
160	5GKI2X0126
190	5GKI2X0127
220	5GKI2X0128
260	5GKI2X0129
290	5GKI2X0130
310	5GKI2X0131

(\*) only for 2XP/2XM

Max transmitted torque = 100 Nm - 74 lbf<sub>t</sub>

## Driving gear shafts

Type 40: SAE 10T 16/32 splined shaft

**Ø18 mm (0.71 in) seal**

Flange	Shaft dimension			
	A		B	
	mm	in	mm	in
SAEA	45.5	1.79	44.5	1.75
SAEB Ø18	44.5	1.75	44.5	1.75

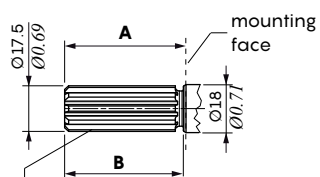

splined profile: SAE 10T - 16/32 DP - GR2

Driving gear shaft kit	
Displacement	Ordering codes
040	5GKI2X0143*
060	5GKI2X0144*
080	5GKI2X0145*
110	5GKI2X0146
140	5GKI2X0147
160	5GKI2X0148
190	5GKI2X0149
220	5GKI2X0150
260	5GKI2X0151
290	5GKI2X0152
310	5GKI2X0153

(\* ) only for 2XP/2XM

Max transmitted torque = 130 Nm - 96 lbf<sub>t</sub>

**Ø22 mm (0.87 in) shaft and flange configuration**

**Flange kit**

**Ø22 mm (0.87 in) SAEB flange: cast iron type**

This flange kit is specifically designed to be combined with Ø22 mm (0.866 in) gear shaft.

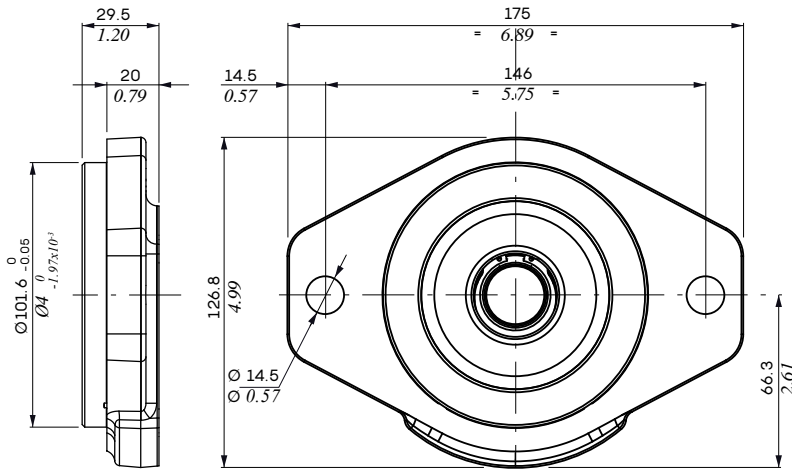

Ordering codes		
Ø22x30 mm (0.866x1.18 in) shaft seal ring		
B		
up to 3 bar (43.5 psi)		
NBR	N	5GKFX2P016
FPM	V	5GKFX2P016V

**Gear support kit**

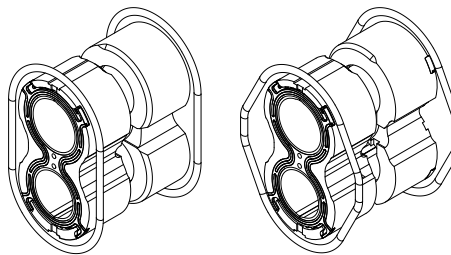

Ordering codes			
Seals material		2XP aluminium pump	2XPW cast iron pump
NBR	N	5GKS20019	5GKS20020
FPM	V	5GKS20049	5GKS20050

**Driving gear shafts**

**Type 45: SAE 13T splined shaft**

**Ø22 mm (0.87 in)**

This driving gear shaft can be used only with its dedicated flange and gear support kit.

Flange	Shaft dimension			
	A		B	
	mm	in	mm	in
SAEB	41.2	1.62	34	1.34

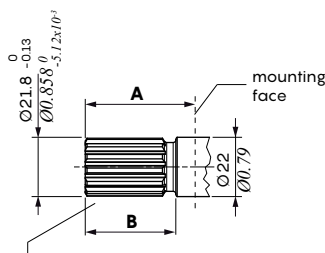

splined profile: 13T 16/32 DP ANSI B 92.1-1996

Max transmitted torque = 280 Nm - 207 lbft

Driving gear shaft kit	
Displacement	Ordering codes
040	5GKI2X0088*
060	5GKI2X0089*
080	5GKI2X0090*
110	5GKI2X0091
140	5GKI2X0092
160	5GKI2X0093
190	5GKI2X0094
220	5GKI2X0095
260	5GKI2X0096
290	5GKI2X0097
310	5GKI2X0098

(\*) only for 2XP/2XM

## Flange kit with outboard bearing (SUP version)

SUP type flanges are completed with radial load bearing and dedicated shaft. These flanges require special 18F type drive gear.

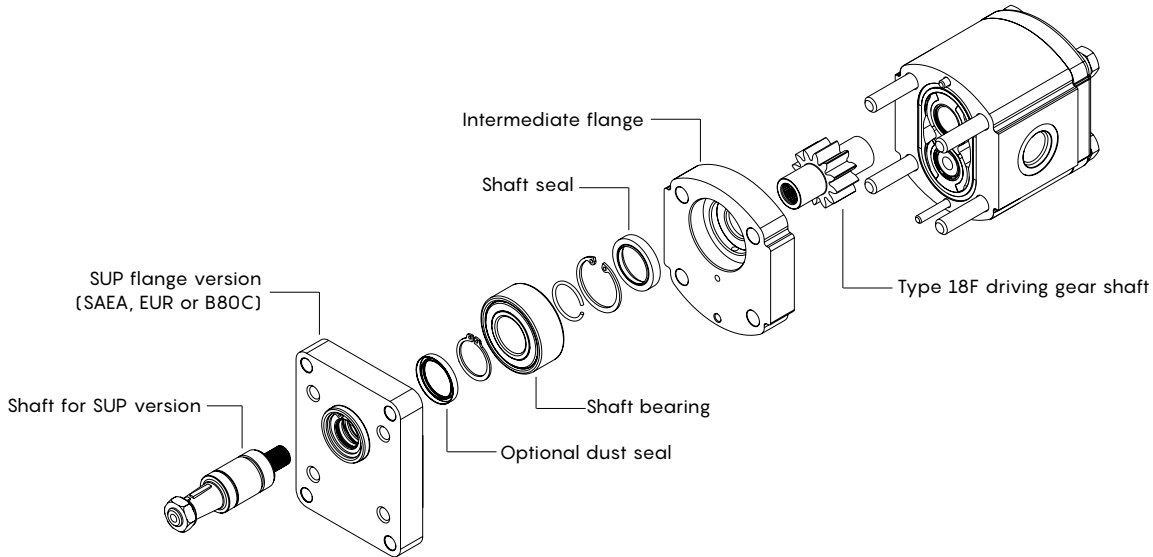

## Shaft sealing (main sealing)

Shaft seal configuration	Pressure code	
	H	K
	Pumps - Motors motors with external drain	Unidirectional motors
<b>With shaft seal, dust seal and shaft bearing</b>	Max pressure up to 8 bar (116 psi) @ 1000 rpm 1.9 bar (27.5 psi) @ 4000 rpm	Max pressure up to 30 bar (435 psi) @ 1000 rpm 7.6 bar (110.2 psi) @ 4000 rpm

### With shaft seal, dust seal (optional) and shaft bearing

Flange example: SUPEUR  
**2XP-A-160-R-SUPEUR-H-N-10-0-G34G12**

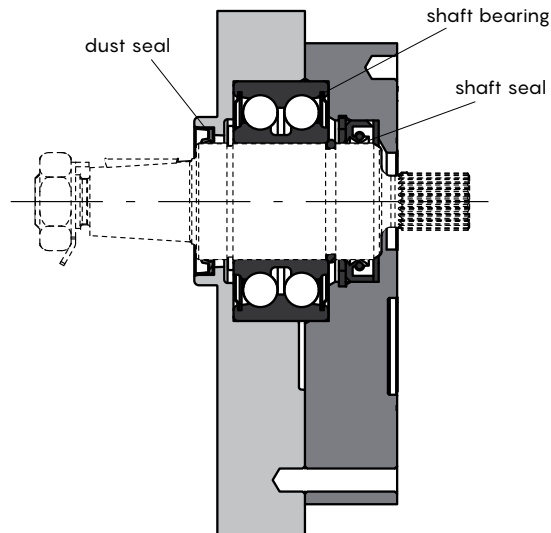

Flange kit with outboard bearing (SUP version)

Bearing life expectancy

SUP flanges are available with shaft seal, dust seal (optional) and shaft bearing. The drawings represents the aluminium SUP version. For cast iron version, shaft type 18F, dedicated shaft features, O-ring combination and other information please contact our Sales Dpt.

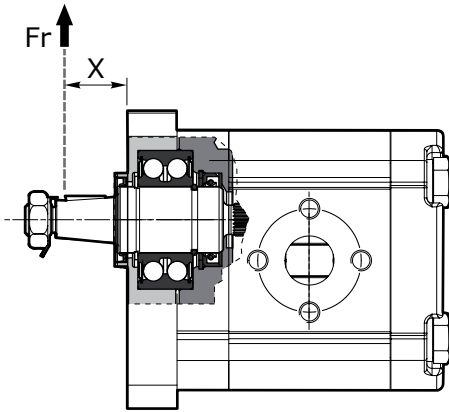

X - Distance of the radial load result from the mounting flange mm (in)

Fr - Radial load

Example	
Fr radial load	1300 N (292 lbf)
X	20 mm (0.787 in)
Speed	1500 rpm
Rated fatigue life	2100 h

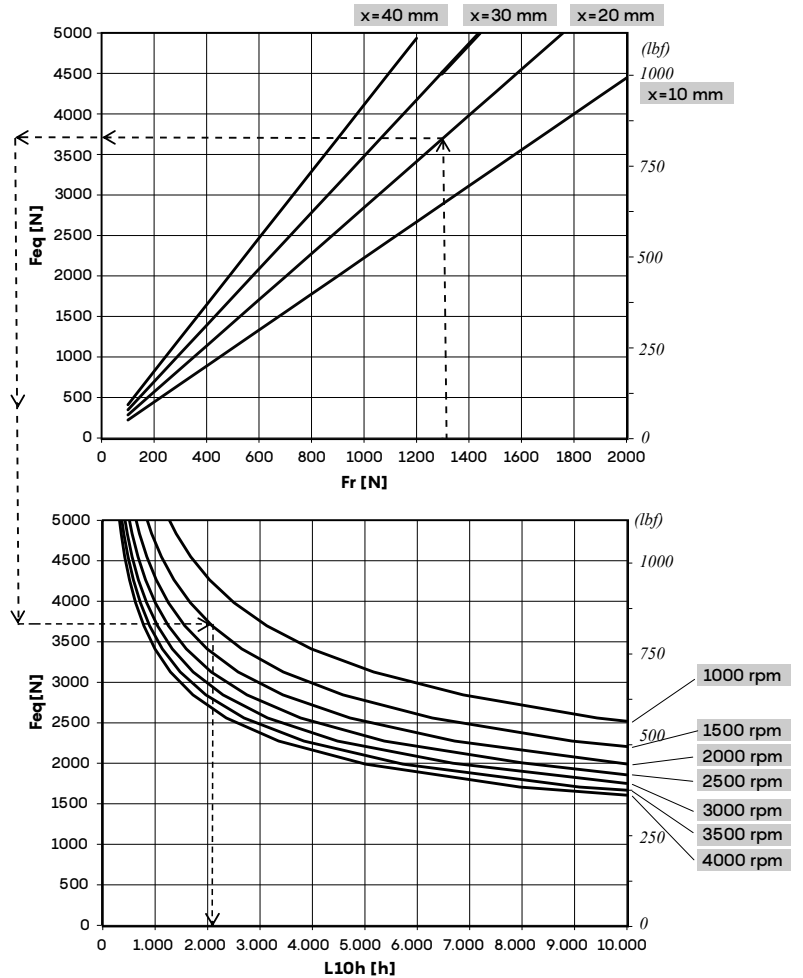

## Flange kit with outboard bearing (SUP version)

### 2XP/2XM main dimensional data

#### Description example with outboard bearing (SUP version)

Pump: 2XP-A-140-D-SUPSAEA-B-N-30-0-U12U10

Motor: 2XM-A-140-D-SUPSAEA-B-N-10-0-U12U10

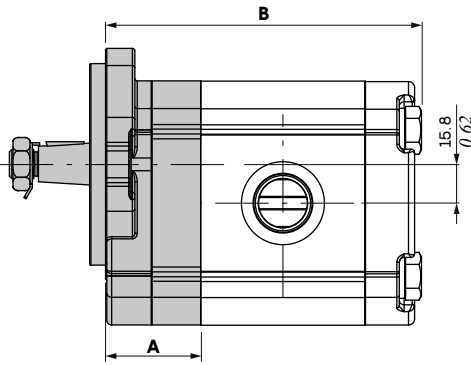

Dimension **B** is referred to aluminium pump with standard aluminium rear cover (without ports). For SUP flanges dimensions see related pages

Flange type							
Dimension A							
EUR		SAEA		B80		B50	
mm	in	mm	in	mm	in	mm	in
39	1.54	39	1.54	41	1.61	39	1.54

Displacement	Dimension B							
	EUR		SAEA		B80		B50	
	mm	in	mm	in	mm	in	mm	in
<b>040</b>	113.1	4.45	113.1	4.45	115.1	4.53	113.1	4.45
<b>060</b>	116.4	4.58	116.4	4.58	118.4	4.66	116.4	4.58
<b>080</b>	120.6	4.75	120.6	4.75	122.6	4.83	120.6	4.75
<b>110</b>	124.7	4.91	124.7	4.91	126.7	4.99	124.7	4.91
<b>140</b>	129.7	5.11	129.7	5.11	131.7	5.19	129.7	5.11
<b>160</b>	133.9	5.27	133.9	5.27	135.9	5.35	133.9	5.27
<b>190</b>	138.9	5.47	138.9	5.47	140.9	5.55	138.9	5.47
<b>220</b>	143.6	5.65	143.6	5.65	145.6	5.73	143.6	5.65
<b>260</b>	149.7	5.89	149.7	5.89	151.7	5.97	149.7	5.89
<b>290</b>	153	6.02	153	6.02	155	6.10	153	6.02
<b>310</b>	158.1	6.22	158.1	6.22	160.1	6.30	158.1	6.22

### Ordering codes

The available **SUP** type flanges codes are listed below.

Different combinations of flanges, shafts and seal types are possible; please contact our Sales Dpt.

#### Important!

The shafts in the table below highlighted with "\*" are dedicated exclusively to the SUP flanges.

#### Aluminium types

SUPEUR flange		
Shaft type	Seal type	Code
10	NBR	H 5GKU2A1010
		K 5GKU2A1013
	FPM	H 5GKU2A1015
		K -
46*	NBR	H 5GKU2A4604
		K 5GKU2A4607
	FPM	H 5GKU2A4605
		K -
47*	NBR	H 5GKU2A4705
		K 5GKU2A4706
	FPM	H 5GKU2A4707
		K -
48*	NBR	H 5GKU2A4803
		K 5GKU2A4802
		5GKU2A4804
		-

SUPSAEA flange		
Shaft type	Seal type	Code
30	NBR	H 5GKU2A3001
		K 5GKU2A3002
	FPM	H 5GKU2A3003
		K -
31	NBR	H 5GKU2A3104
		K 5GKU2A3105
	FPM	H 5GKU2A3106
		K -
32	NBR	H 5GKU2A3202
		K 5GKU2A3203
	FPM	H 5GKU2A3204
		K -

SUPB80 flange		
Shaft type	Seal type	Code
11	NBR	H 5GKU2A1108
		K 5GKU2A1107
	FPM	H 5GKU2A1110
		K -
51*	NBR	H 5GKU2A5111
		K 5GKU2A5103
	FPM	H 5GKU2A5104
		K -

SUPB50 flange			
Shaft type	Seal type	B50CX Code	B50CY code
11	NBR	H 5GKU2A1105	5GKU2A1106
		K 5GKU2A1111	5GKU2A1109
	FPM	H 5GKU2A1112	5GKU2A1113
		K -	-
51*	NBR	H 5GKU2A5105	5GKU2A5108
		K 5GKU2A5106	5GKU2A5109
	FPM	H 5GKU2A5107	5GKU2A5110
		K -	-



Flange kit with outboard bearing (SUP version)

Shaft dimensions

The shafts represented below are dedicated exclusively to the SUP flanges; for standard shaft see pages from 22 to 26

Type 46

Dimension A is referred to SUPEUR flange

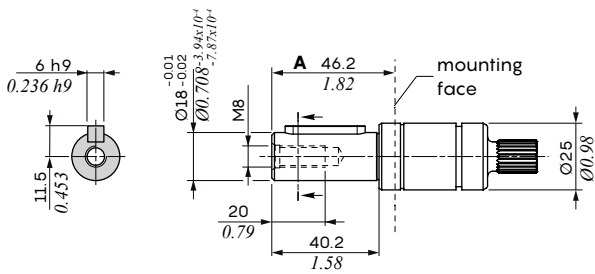

Type 47

Dimension A is referred to SUPEUR flange

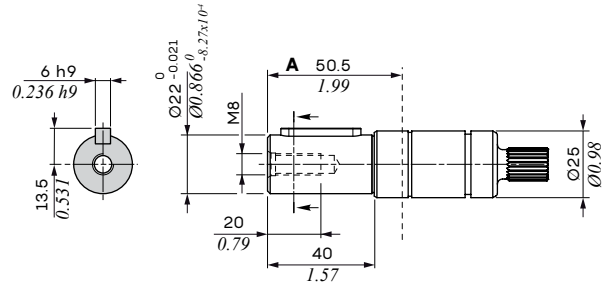

Type 48

Dimension A is referred to SUPEUR flange

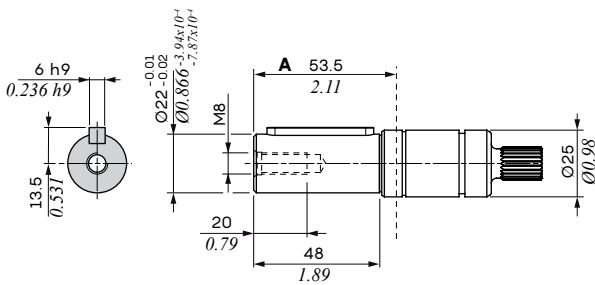

Type 51: conical 1:5 shaft

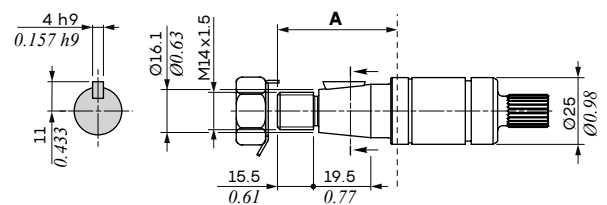

Flange	Shaft dimension	
	mm	in
SUPB80	44.9	1.77
SUPB50	46.9	1.85

Driving gear

Type 18F

SUP type flanges require the female/female driving gear represented below. This shaft is also used for the secondary stage in tandem pumps

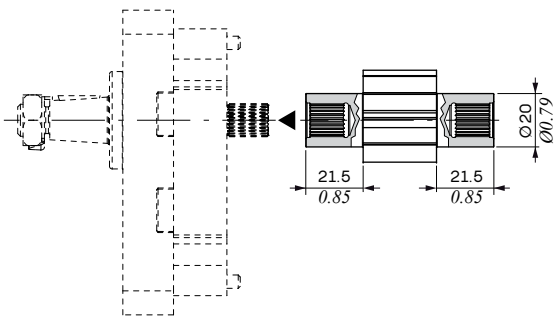

Driving gear shaft kit			
Displacement	Ordering codes	Displacement	Ordering codes
040	5GKI2X0132*	190	5GKI2X0138
060	5GKI2X0133*	220	5GKI2X0139
080	5GKI2X0134*	260	5GKI2X0140
110	5GKI2X0135	290	5GKI2X0141
140	5GKI2X0136	310	5GKI2X0142
160	5GKI2X0137		

(\* ) only for 2XP/2XM

Max transmitted torque = 100 Nm - 74lbf<sub>t</sub>

## Driven gears

Driven gear shaft					
Displacement	Ordering codes	Displacement	Ordering codes	Displacement	Ordering codes
040	010053334999	140	010053335399	260	010053335799
060	010053335099	160	010053335499	290	010053449099
080	010053335199	190	010053335599	310	010053335899
110	010053335299	220	010053335699		

## Standard bodies

### Aluminium body

The body kits can't be ordered as spare parts and dimensions are the same for all port connections. For informations about customization please contact our Sales Dpt.

Body dimensions				
Displacement	A		B	
	mm	in	mm	in
040	50.8	2	25.4	1
060	54.1	2.13	27.05	1.06
080	58.3	2.29	29.15	1.15
110	62.4	2.46	31.2	1.23
140	67.4	2.65	33.7	1.33
160	71.6	2.82	35.8	1.41
190	76.6	3.01	38.3	1.51
220	81.6	3.21	40.8	1.61
260	87.4	3.44	43.7	1.72
290	90.7	3.57	45.35	1.78
310	95.8	3.77	47.9	1.88

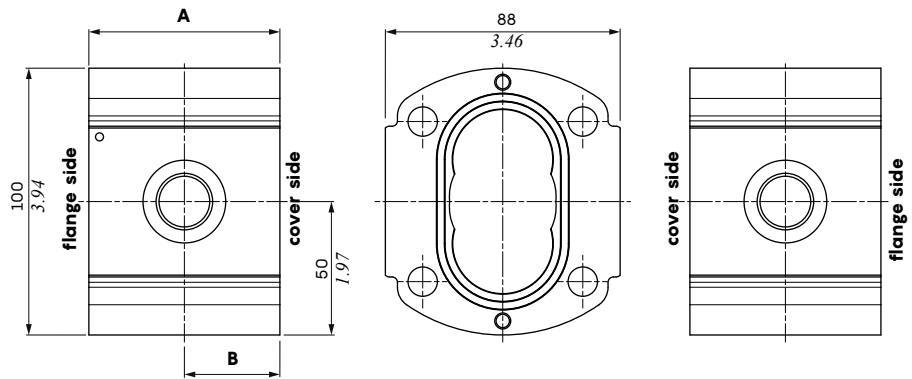

### Cast iron body

The body kits can't be ordered as spare parts and dimensions are the same for all port connections. For informations about customization please contact our Sales Dpt..

Body dimensions				
Displacement	A		B	
	mm	in	mm	in
110	62.4	2.46	31.2	1.23
140	67.4	2.65	33.7	1.33
160	71.6	2.82	35.8	1.41
190	76.6	3.01	38.3	1.51
220	81.6	3.21	40.8	1.61
260	87.4	3.44	43.7	1.72
290	90.7	3.57	45.35	1.78
310	95.8	3.77	47.9	1.88

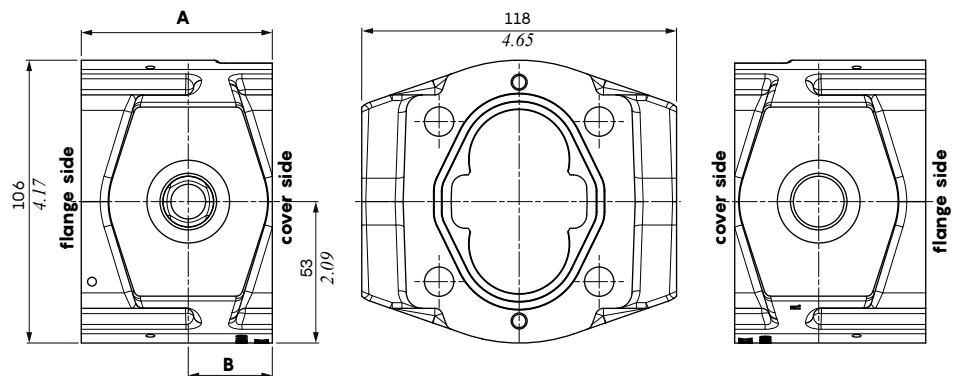

## Special and dedicated bodies

### Aluminium body

These versions can be used in case of common suction in tandem aluminum configurations or when special rear porting are required.

They are specifically designed for to have the same flow characteristics as the 2XPW/2XMW.

External dimension and ports position are the same of the aluminium standard body; cast iron flange and cover are recommended in the installation due to larger sealing area.

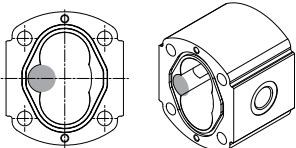
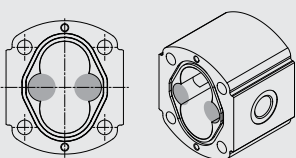
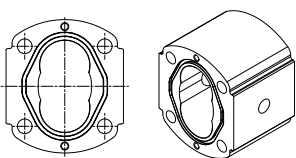
Special body summary table		
Body type		Description / Application
LAU		<ul style="list-style-type: none"> <li>- Single enlarged flow connection</li> <li>- For common suction tandem configuration</li> </ul>
MU		<ul style="list-style-type: none"> <li>- Double enlarged flow connection: suction and delivery</li> <li>- For displacement from 040 to 140 recommended pressures are: P1 = 230 bar P2 = 240 bar P3 = 250 bar</li> <li>- For oversized rear porting</li> </ul>
SGR		<ul style="list-style-type: none"> <li>- Configuration without flow connection enlargement and port machining</li> <li>- Only as spare part for tandem secondary section</li> </ul>

### Description example

Pump: 2XP-A-160(LAU)-D-EUR-B-N-10-4-U12U10

Displacement	Body dimensions			
	A		B	
	mm	in	mm	in
040	50.8	2	25.4	1
060	54.1	2.13	27.05	1.06
080	58.3	2.29	29.15	1.15
110	62.4	2.46	31.2	1.23
140	67.4	2.65	33.7	1.33
160	71.6	2.82	35.8	1.41
190	76.6	3.01	38.3	1.51
220	81.6	3.21	40.8	1.61
260	87.4	3.44	43.7	1.72
290	90.7	3.57	45.35	1.78
310	95.8	3.77	47.9	1.88

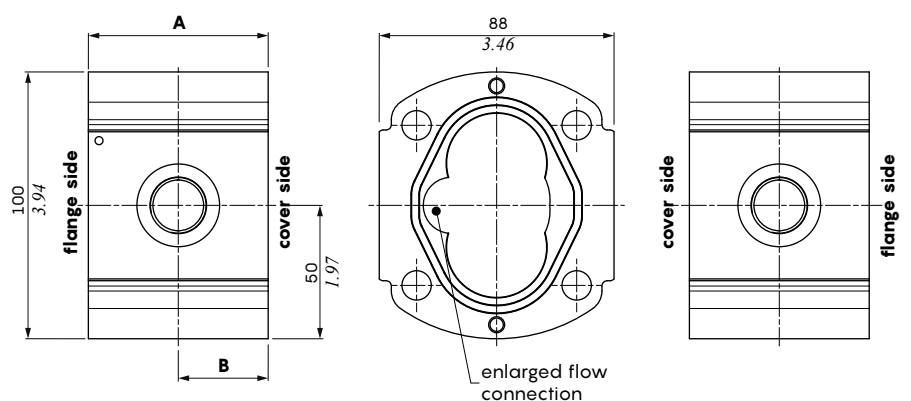

## Standard cover kits

### Aluminium cover kits

#### Without ports

#### Description example

Pump: 2XP-A-040-D-EUR-B-N-10-0-G12G12

Motor: 2XM-A-110-R-EUR-H-N-10-0-G12G12-DRENG14

Available on	
2XP/2XM	2XPW/2XMW
●	—

#### Connection position 0

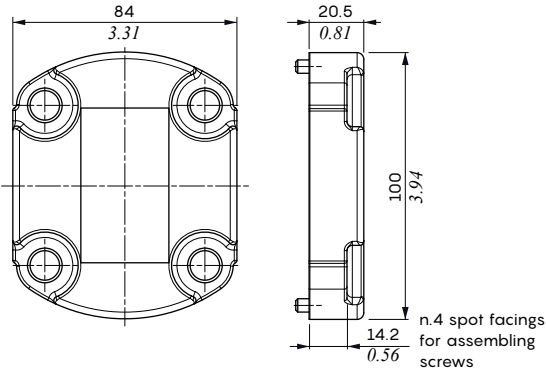

#### Connection position 0 - DREN

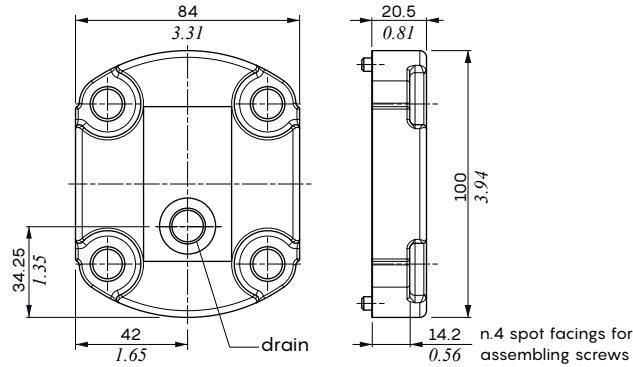

#### Ordering codes

Pump/motor connection position	Ports code "G" (BSP threading)				Ports code "U" (UN-UNF threading)			
	CODE	IN	OUT	DRAIN**	CODE	IN	OUT	DRAIN**
0	5GKC20005	-	-	-	5GKC20005	-	-	-
0...DREN...	5GKC2G004	-	-	G14	5GKC2U004	-	-	U6

NOTE (\*\*): plug the DRAIN port in case of pump or unidirectional motor

#### With ports

#### Only for pumps or unidirectional motors - Description example

Pump: 2XP-A-040-D-EUR-B-N-10-4-G12G12

Motor: 2XM-A-110-D-EUR-H-N-10-4-G12G34

Available on	
2XP/2XM	2XPW/2XMW
●	—

#### Connection position 1/3/4 - DREN

For suction up to 24 l/min (6.3 US gpm) max.

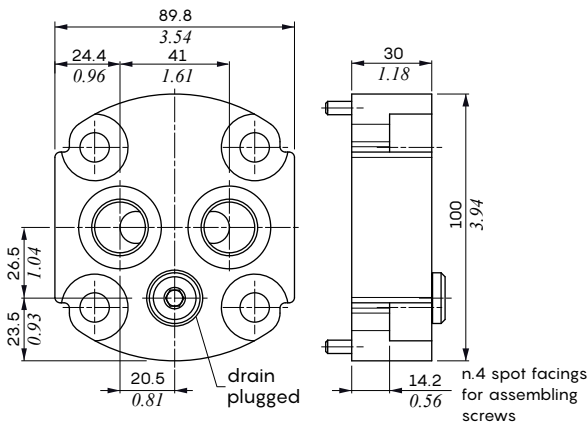

#### Connection position 1/3/4 - DREN

For suction up to 45 l/min (11.9 US gpm) max.  
This cover requires type MU body kit.

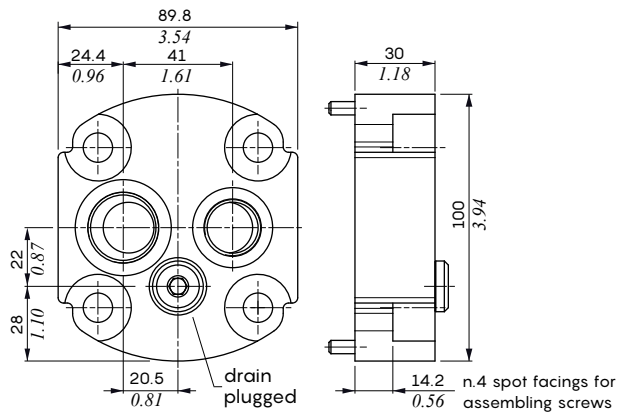

#### Ordering codes

Pump/motor connection position	Ports code "G" (BSP threading)				Ports code "U" (UN-UNF threading)			
	CODE	IN*	OUT*	DRAIN**	CODE	IN*	OUT*	DRAIN**
1/3/4...DREN...(standard body)	5GKC2G014	G12	G12	plugged	5GKC2U015	U10	U10	plugged
1/3/4...DREN...(MU type body)	5GKC2G012	G12	G34	plugged	5GKC2U000	U10	U12	plugged

NOTE (\*): for connection position 1/3 plug the unused port - (\*\*): plug the DRAIN port in case of pump or unidirectional motor

**Aluminium cover kits**

**With ports**

**For pumps and motors - Description example**

**Motor: 2XM-A-110-R-EUR-H-N-10-4-G34G34-DRENG14**

Available on	
2XP/2XM	2XPW/2XMW
•	-

**Connection position 1/3/4 - DREN**

For suction up to 45 l/min (11.9 US gpm) max.  
This cover requires type MU body kit.

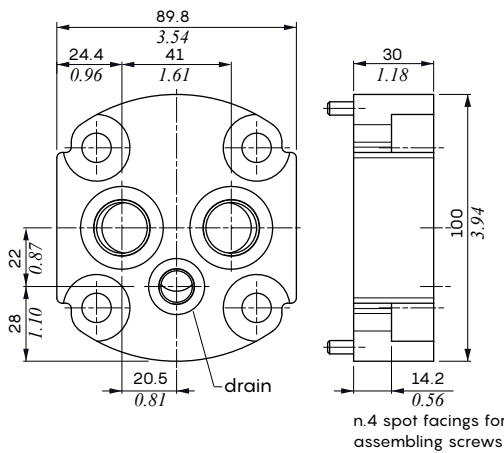

**Connection position 1/3/4 - DREN**

For suction up to 45 l/min (11.9 US gpm) max.  
This cover requires type MU body kit.  
Enlarged ports version

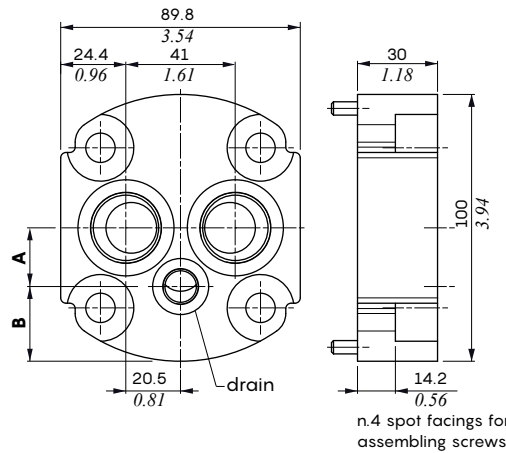

Cover dimensions		
Quote	BSP	UN-UNF
<b>A</b>	mm	22
	in	0.87
<b>B</b>	mm	28
	in	1.10

Ordering codes								
Pump/motor connection position	Ports code "G" (BSP threading)				Ports code "U" (UN-UNF threading)			
	CODE	IN*	OUT*	DRAIN**	CODE	IN*	OUT*	DRAIN**
<b>1/3/4...DREN... (MU type body)</b>	5GKC2G000	G12	G12	G14	-	-	-	-
	5GKC2G002	G34	G34	G14	5GKC2U013	U12	U12	U6

NOTE (\*): for connection position 1/3 plug the unused port - (\*\*): plug the DRAIN port in case of pump or unidirectional motor

## Standard cover kits

### Cast iron cover kits

Pumps with cast iron covers, except for the type without ports, require UNI 5931 screws; for screws kit see page

#### Without ports

#### Description example

**Pump:** 2XP-G-040-D-EUR-B-N-10-0-N13N13

**Motor:** 2XMW-G-110-R-B80C-K-V-15-0-G34G34-DRENG14

Available on	
2XP/2XM	2XPW/2XMW
•	•

#### Connection position 0

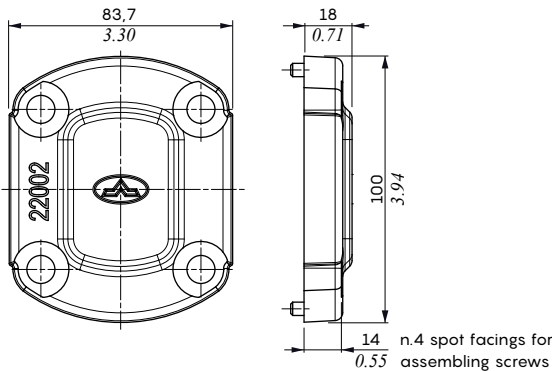

#### Connection position 0 - DREN

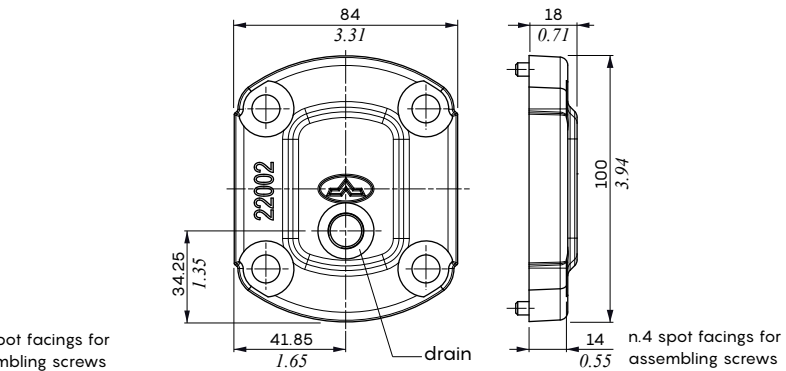

Pump/motor connection position	Ordering codes							
	Ports code "G" (BSP threading)				Ports code "U" (UN-UNF threading)			
	CODE	IN	OUT	DRAIN*	CODE	IN	OUT	DRAIN*
0	5GKC20001	-	-	-	5GKC20001	-	-	-
0...DREN...	5GKC2G207	-	-	G14	5GKC2U003	-	-	U6

NOTE (\*) : plug the DRAIN port in case of pump or unidirectional motor

#### With ports

#### Only for pumps or unidirectional motors - Description example

**Pump:** 2XP-G-040-D-SAEA-B-N-14-4-U10U12

**Motor:** 2XM-G-040-D-SAEA-H-N-14-4-U10U12

Available on	
2XP/2XM	2XPW/2XMW
•	•

#### Connection position 1/3/4

For suction up to 45 l/min (11.9 US gpm) max.

For aluminium pump/motor this cover requires type MU body kit.

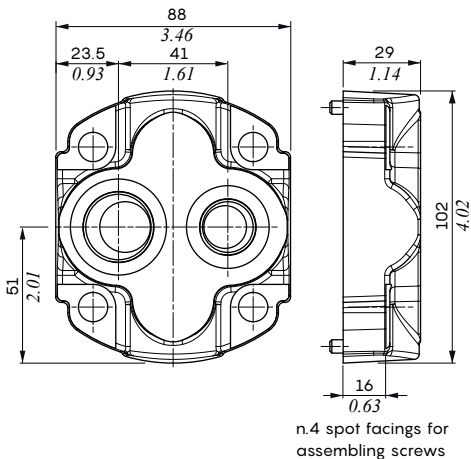

Pump/motor connection position	Ordering codes			
	Ports code "G" (BSP threading)			
	CODE	IN*	OUT*	DRAIN
1/3/4...DREN... (Aluminium MU type body)	5GKC2G016	G12	G34	-
Pump/motor connection position	Ports code "U" (UN-UNF threading)			
	CODE	IN*	OUT*	DRAIN
	1/3/4...DREN... (Aluminium MU type body)	5GKC2U011	U10	U12

NOTE (\*) : for connection position 1/3 plug the unused port

**Cast iron cover kits**

**With ports**

**For pumps and all motors - Description example**

**Motor: 2XMW-G-040-R-SAEA-H-N-14-4-U10U10-DRENU6**

Available on	
2XP/2XM	2XPW/2XMW
•	•

**Connection position 1/3/4**

For suction up to 24 l/min (6.3 US gpm) max.

**Connection position 1/3/4**

For suction up to 24 l/min (6.3 US gpm) max.  
Enlarged ports version

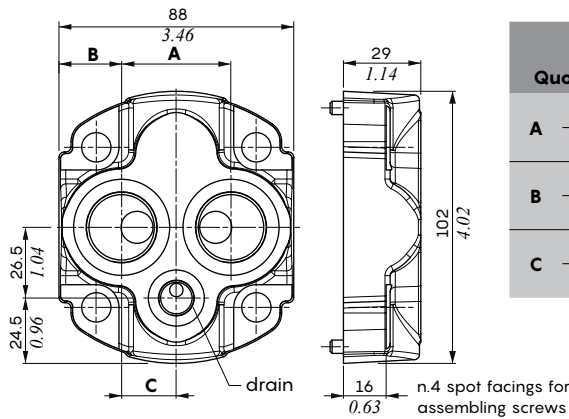
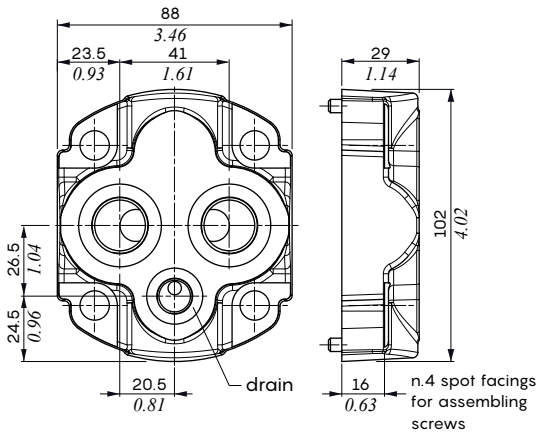

Cover dimensions		
Quote	BSP	UN-UNF
A	mm	41
	in	1.61
B	mm	23.5
	in	0.93
C	mm	20.5
	in	0.81

Connection position	Ordering codes							
	Ports code "G" (BSP threading)				Ports code "U" (UN-UNF threading)			
	CODE	IN*	OUT*	DRAIN**	CODE	IN*	OUT*	DRAIN**
1/3/4...DREN...	5GKC2G017	G12	G12	G14	5GKC2U014	U10	U10	U6
	5GKC2G121	G34	G34	G14	5GKC2U010	U12	U12	U6

NOTE (\*): for connection position 1/3 plug the unused port - (\*\*): plug the DRAIN port in case of pump or unidirectional motor

**Connection position 1/3/4 - DREN**

For suction up to 45 l/min (11.9 US gpm) max.  
For aluminium pump/motor this cover requires type MU body kit.  
Enlarged ports version.

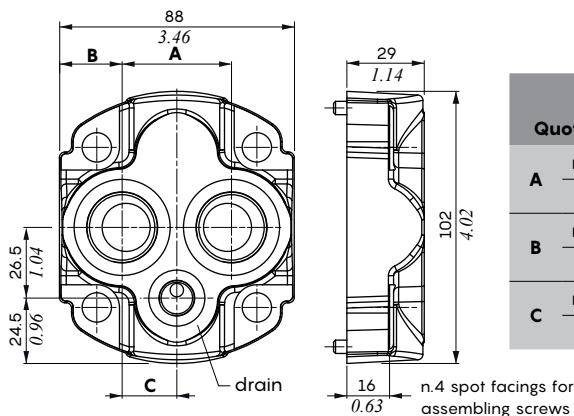

Cover dimensions		
Quote	BSP	UN-UNF
A	mm	41
	in	1.61
B	mm	23.5
	in	0.93
C	mm	20.5
	in	0.81

Pump/motor connection position	Ordering codes							
	Ports code "G" (BSP threading)				Ports code "U" (UN-UNF threading)			
	CODE	IN*	OUT*	DRAIN**	CODE	IN*	OUT*	DRAIN**
1/3/4...DREN... (Aluminium MU type body)	5GKC2G120	G34	G34	G14	5GKC2U201	U12	U12	U6

NOTE (\*): for connection position 1/3 plug the unused port - (\*\*): plug the DRAIN port in case of pump or unidirectional motor

## Social cover kits

### With auxiliary valves

#### 6B - Cast iron type: C1 configuration

Cover fitted with auxiliary valves; available valves are anti-shock plus anti-cavitation and only anti-cavitation types. Valve blanking plug is also available.

This cover requires UNI 5931 screws; for screws kit see page

IMPORTANT: for complete cover ordering code please contact Sales Department.

Available on	
2XP/2XM	2XPW/2XMW
●	●

### Motor description example

**2XMW-G-190-R-SAEA-K-V-10-0-G34G34-C1-DU(140)\S(TAP)-DRENINFG14-<CVN>**

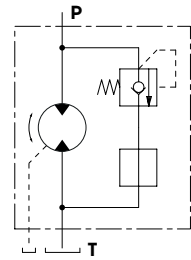
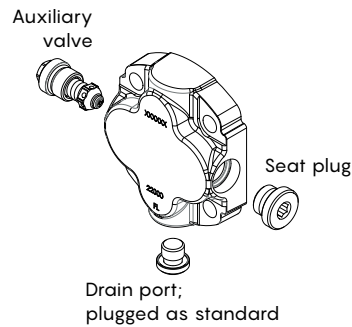
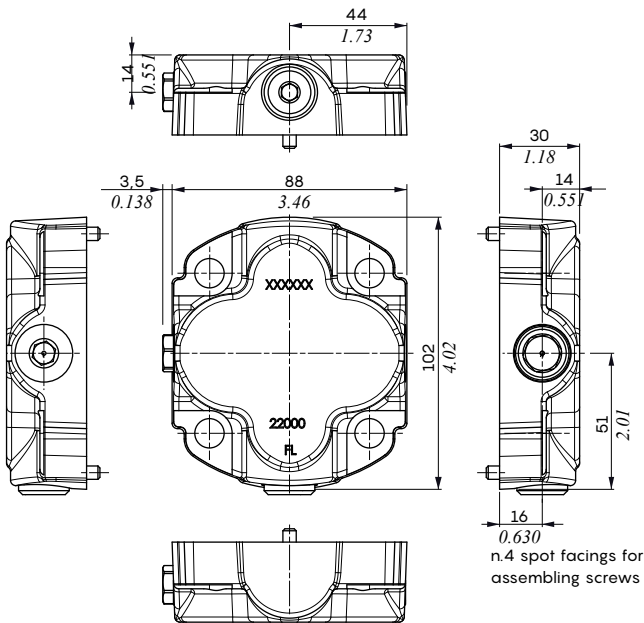
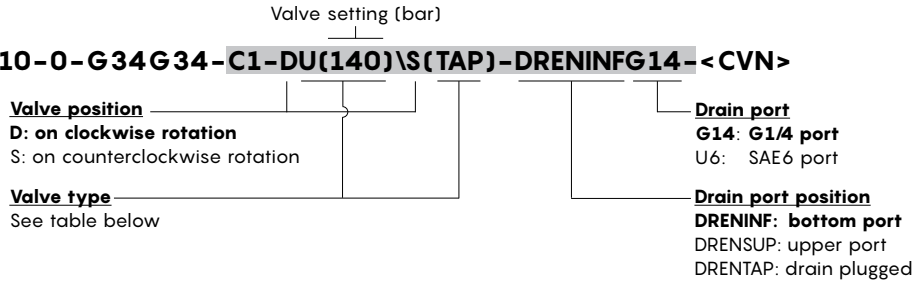

Valves ordering codes				
Valve type	CODE	SYMBOL	DESCRIPTION	Tightening
TAP	XTAP522260F		Seat plug	Allen wrench 8 24 Nm (17.7 lbft)
	XTAP522441* XTAP522441V**		Valve blanking plug	Wrench 13 24 Nm (17.7 lbft)
C	5KIT410000* 5KIT410000V**		Anti-cavitation valve.	Wrench 13 24 Nm (17.7 lbft)
U(...) T setting (bar)	5KIT332...* 5KIT332...V** setting (bar)		Fixed setting anti-shock and anti-cavitation valves with pressure relief function <b>Setting (bar - psi):</b> 25 bar (363 psi)    30 bar (435 psi)    40 bar (580 psi)    50 bar (725 psi)    63 bar (914 psi) 80 bar (1150 psi)    100 bar (1450 psi)    110 bar (1590 psi)    125 bar (1800 psi)    140 bar (2050 psi) 150 bar (2150 psi)    160 bar (2300 psi)    175 bar (2550 psi)    190 bar (2750 psi)    200 bar (2900 psi) 210 bar (3050 psi)    220 bar (3190 psi)    230 bar (3350 psi)    240 bar (3500 psi)    250 bar (3600 psi) 260 bar (3750 psi)    270 bar (3900 psi)    280 bar (4050 psi)    290 bar (4200 psi)    300 bar (4350 psi) 310 bar (4500 psi)    320 bar (4650 psi)    340 bar (4950 psi)    360 bar (5200 psi)    400 bar (5800 psi) 420 bar (6100 psi)	Wrench 13 24 Nm (17.7 lbft)

NOTE: (\*) code is referred to valve with NBR O-ring seals. (\*\*) code is referred to valve with FPM O-ring seals.



**With auxiliary valves**

**6B - Cast iron type: C1 configuration**

**Anti-shock plus anti-cavitation valves setting example**

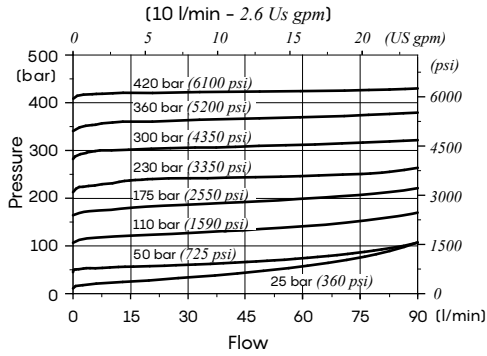

**Anti-shock plus anti-cavitation valves pressure drop**

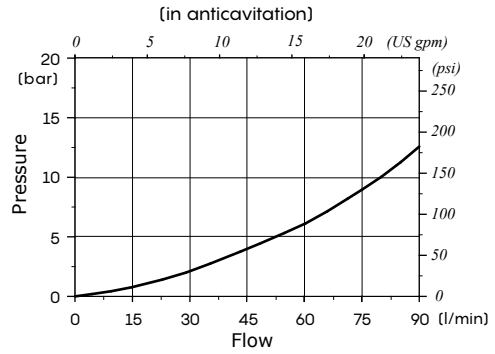

**Anti-cavitation valve pressure drop**

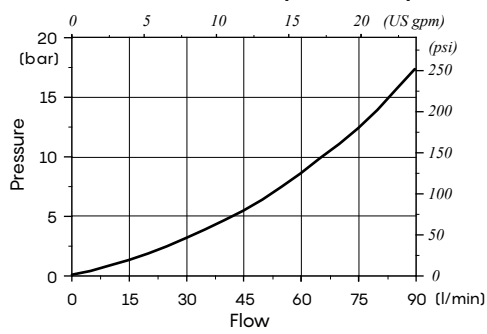

## Special cover kits

### With auxiliary valves

#### 6B - Cast iron type: C3 (C3V) and C4 (C4V) configurations

These covers are configurable with SAE10/2A cavity relief, check or directional valves; the cavity can be on side or upper/bottom position.

C4 (C4V) configuration includes a dedicated drain line for the valves and can be used on pumps and unidirectional motors.

The covers require UNI 5931 screws; for screws kit see page.

IMPORTANT: for complete cover ordering code please contact Sales Department.

Available on	
2XP/2XM	2XPW/2XMW
•	•

#### Motor description example

**2XMW-G-040-S-EUR-B-N-10-0-G34G12-C3\EF10M20NB\4PD(BQP)\G12\DRENINFG14-12VDC-<CVN>**

#### Cover type

**C3:** SAE10/2A cavity on suction side, double drain plugged  
**C3V:** vertical SAE10/2A cavity, double drain plugged  
**C4:** SAE10/2A cavity on suction side, vertical valve drain line  
**C4V:** vertical SAE10/2A cavity, valve drain line on suction side

#### Valve type

**MC10M(XXX)\*:** pressure relief valve, direct acting  
**MP10M(XXX)\*:** pressure relief valve, pilot operated  
**MP10T:** solenoid proportional pressure relief valve, pilot operated; decreasing pressure with increasing current  
**MP10X:** solenoid proportional pressure relief valve, pilot operated; increasing pressure with decreasing current  
**UC10A/001B:** check valve for anticavitation; free flow from 2 to 1  
**UC10C/001B:** check valve for anticavitation; free flow from 1 to 2  
**EC10M/20XX\*\*:** directional solenoid valves, pilot operated, normally closed, open from 1>2  
**EF10M/20XX\*\*:** directional solenoid valves, pilot operated, normally closed, open from 2>1  
**EH10M/20XX\*\*:** directional solenoid valves, pilot operated, normally closed, check in both direction  
**TAP:** seat plugged

#### NOTES:

[\*] substitute "XXX" with valve setting in bar  
 [\*\*] substitute "XX" with valve emergency type; see table on page 52  
 [#] only for solenoid valves

**Coil voltage #**  
 12VDC, 24VDC

**Drain port position**  
**DRENINF:** bottom port  
 DRENSUP: upper port  
 DRENTAP: drain plugged

**Drain port**  
**G14:** G1/4 port  
 U6: SAE6 port

**Valve external drain**  
 -: no drain  
**G12:** G1/2 port  
 U10: SAE10 port

**Coil type #**  
 -: no coil  
**BQP, BH, BER:** coil type is related to the valve; consult the SAE cartridge catalogue for information

**Connector position #**  
**PD:** connection perpendicular to coil axis  
**PL:** connection parallel to coil axis

**Connector type #**  
 0: ISO (standard)      6: female Metri-Pack  
 2: AMP-JPT              7: male Metri-Pack  
 3: Deutsch DT06        8: male Weather-Pack  
**4: Deutsch DT04-2P**    9: female Weather-Pack  
 5: Deutsch DT04-4P

#### C3 (C3V) configurations

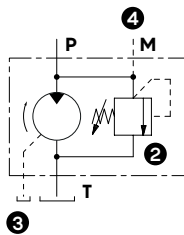

- 1: cover type
- 2: cavity SAE10/2A valve
- 3: drain port; plugged as standard
- 4: pressure gauge arrangement; plugged as standard
- 5: valve external drain port

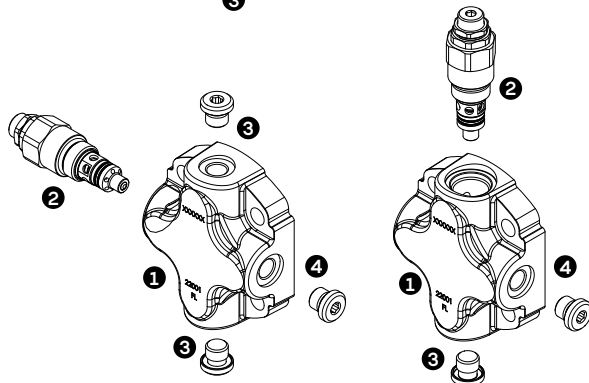

#### C4 (C4V) configurations

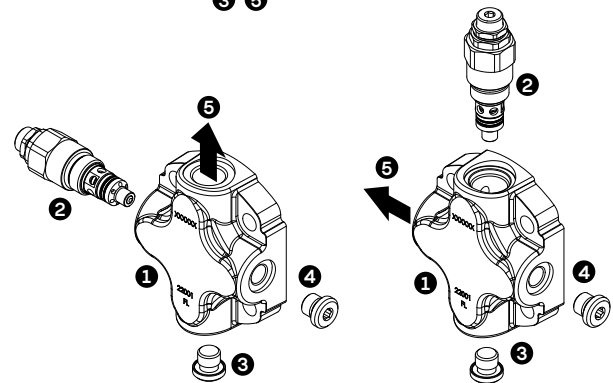
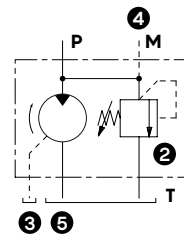

With auxiliary valves

6B - Cast iron type: C3 (C3V) and C4 (C4V) configurations

Configuration C3 dimensions

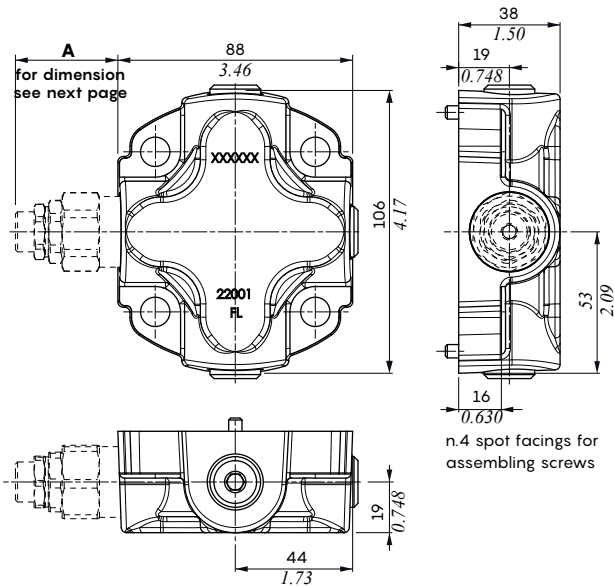

Configuration C3V dimensions

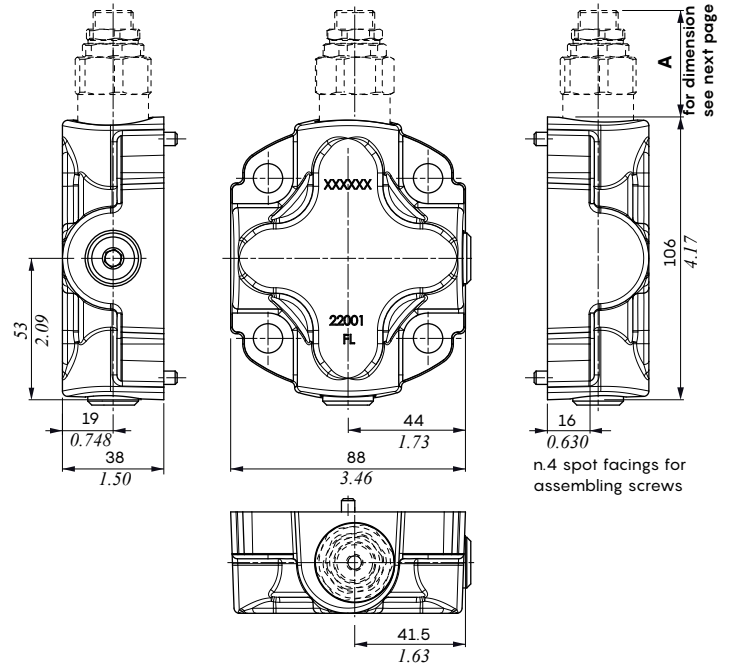

Configuration C4 dimensions

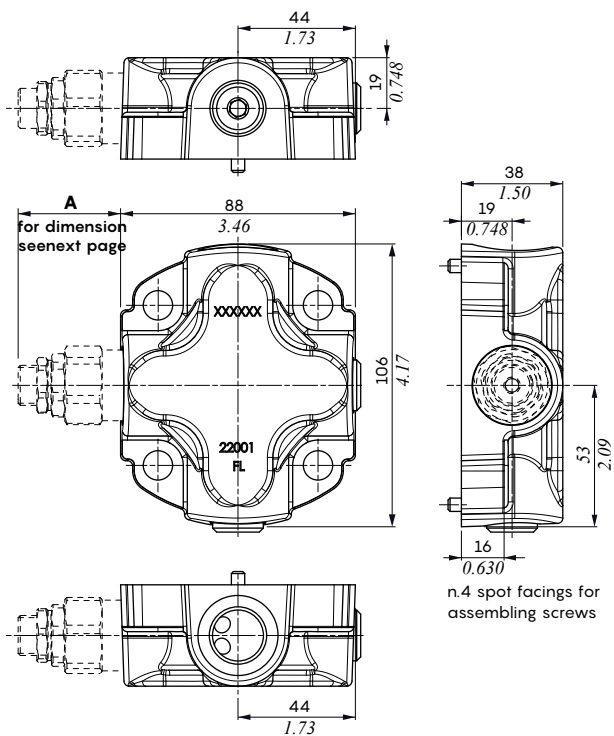

Configuration C4V dimensions

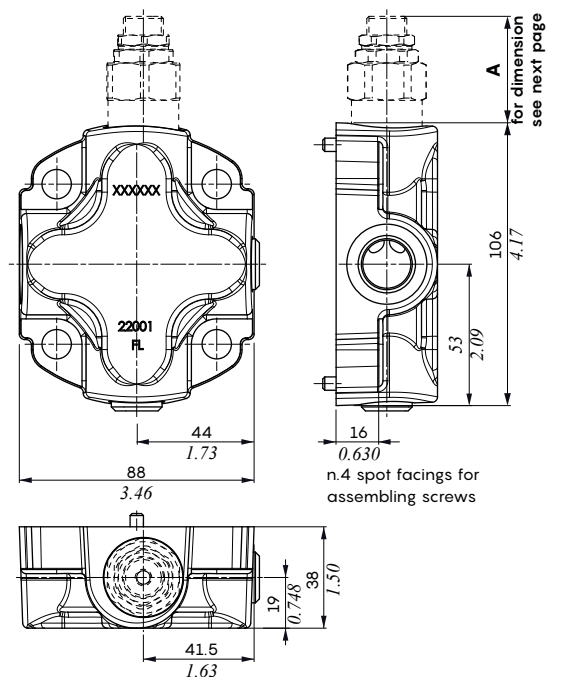



## Special cover kits

### With auxiliary valves

#### 6B - Cast iron type: C3 (C3V) and C4 (C4V) configurations

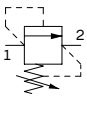
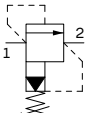
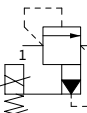
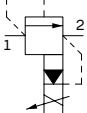
For valves data and features curves please consult SAE cavity cartridges valves catalogue, code D2WWEI01E.

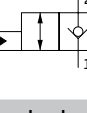
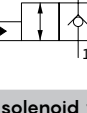
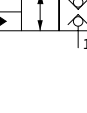
Valves ordering codes					
Valve type	CODE	SYMBOL	DESCRIPTION	Tightening	Dimension A max (see prev. pages)
	XTAP327460		Seat plug	Wrench 27 50 Nm (37 lbft)	6 mm (0.236 in)
<b>Pressure relief valve, direct acting - std. setting @ 5 l/min (1.3 US gpm)</b>					
MC10M/0Y2B	OMC10002027		Range 40-110 bar (580-1900 psi) Std. setting 80 bar (1160 psi)	Wrench 27 50 Nm (37 lbft)	40.5 mm (1.59 in)
MC10M/0Y3B	OMC10002028		Range 110-220 bar (1900-3200 psi) Std. setting 175 bar (2550 psi)		
MC10M/0Y4B	OMC10002029		Range 200-260 bar (2900-3770 psi) Std. setting 220 bar (3200 psi)		
<b>Pressure relief valve, pilot operated - std. setting @ 5 l/min (1.3 US gpm)</b>					
MP10M/0S1B	OMP10002091		Range 5-50 bar (72.5-725 psi) Std. setting 30 bar (435 psi)	Wrench 27 50 Nm (37 lbft)	44.5 mm (1.75 in)
MP10M/0S2B	OMP100020A00		Range 50-220 bar (725-3200 psi) Std. setting 150 bar (2200 psi)		
MP10M/0S3B	OMP10002093		Range 150-350 bar (2200-5100 psi) Std. setting 250 bar (3600 psi)		
<b>Solenoid proportional pressure relief valve, pilot operated - Decreasing pressure with increasing current</b>					
MP10T/001B	OMP10002051		Range 8-130 bar (116-1900 psi)	Wrench 27 50 Nm (37 lbft)	96 mm (3.78 in)
MP10T/002B	OMP10002052		Range 8-180 bar (116-2600 psi)		
MP10T/003B	OMP10002053		Range 8-240 bar (116-3500 psi)		
<b>Solenoid proportional pressure relief valve, pilot operated - Increasing pressure with decreasing current</b>					
MP10X/001B	OMP10002054		Range 10-120 bar (145-1750 psi)	Wrench 27 50 Nm (37 lbft)	82 mm (3.23 in)
MP10X/002B	OMP10002055		Range 10-160 bar (145-2300 psi)		
MP10X/003B	OMP10002056		Range 10-230 bar (145-3350 psi)		
MP10X/004B	OMP10002057		Range 10-350 bar (145-5100 psi)		
<b>Check valve for anticavitation</b>					
UC10A/001B	OUC10002000		Opening pressure 0.5 bar (7.3 psi) Note: the installation is possible on C3V and C4V cover types	Wrench 27 50 Nm (37 lbft)	10 mm (0.394 in)
UC10C/001B	OUC10002009		Opening pressure 0.5 bar (7.3 psi)	Wrench 24 60 Nm (44 lbft)	4.5 mm (0.177 in)
<b>Directional solenoid valves, pilot operated - Normally closed, open from 1&gt;2</b>					
EC10M/20NB	OEC10002013		Without emergency	Wrench 27 50 Nm (37 lbft)	59 mm (2.32 in)
EC10M/20FB	OEC10002017		Pull-button emergency		87 mm (3.43 in)
EC10M/20TB	OEC10002018		NScrew type emergency		73.5 mm (2.89 in)
EC10M/20QB	OEC10002019		Pull and twist type with detent emergency		80 mm (3.15 in)
<b>Directional solenoid valves, pilot operated - Normally closed, open from 2&gt;1</b>					
EF10M/20NB	OEF10002001		Without emergency	Wrench 27 50 Nm (37 lbft)	59 mm (2.32 in)
EF10M/20FB	OEF10002005		Push-button emergency		87 mm (3.43 in)
EF10M/20TB	OEF10002006		Screw type emergency		73.5 mm (2.89 in)
EF10M/20QB	OEF10002007		Push and twist type with detent emergency		80 mm (3.15 in)
<b>Directional solenoid valves, pilot operated - Normally closed, check in both direction</b>					
EH10M/20NB	OEH10002001		Without emergency	Wrench 27 50 Nm (37 lbft)	59 mm (2.32 in)
EH10M/20FB	OEH10002005		Pull-button emergency		87 mm (3.43 in)
EH10M/20TB	OEH10002006		Screw type emergency		73.5 mm (2.89 in)
EH10M/20QB	OEH10002007		Push and twist type with detent emergency		80 mm (3.15 in)

**With priority valve**

**6B - Cast iron type**

To order the complete cover kit please contact the Sales Department.

Available on	
2XP/2XM	2XPW/2XMW
•	-

**Available circuits**

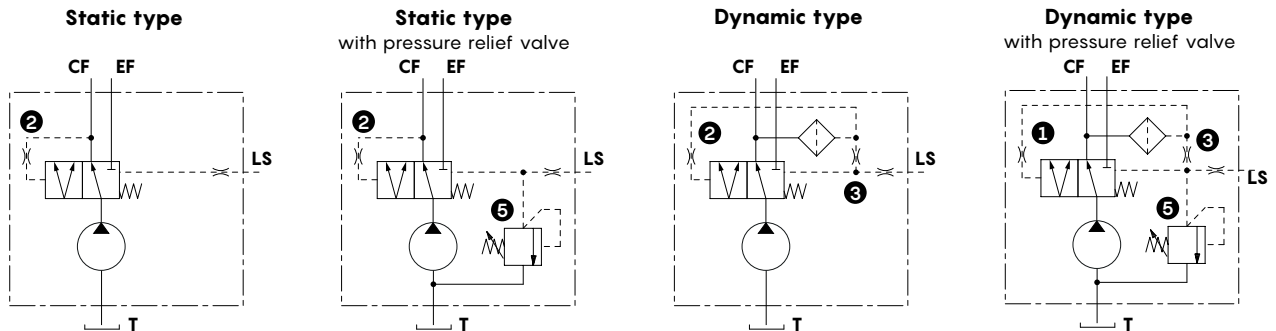

**Description example for Dynamic type with pressure relief valve:**

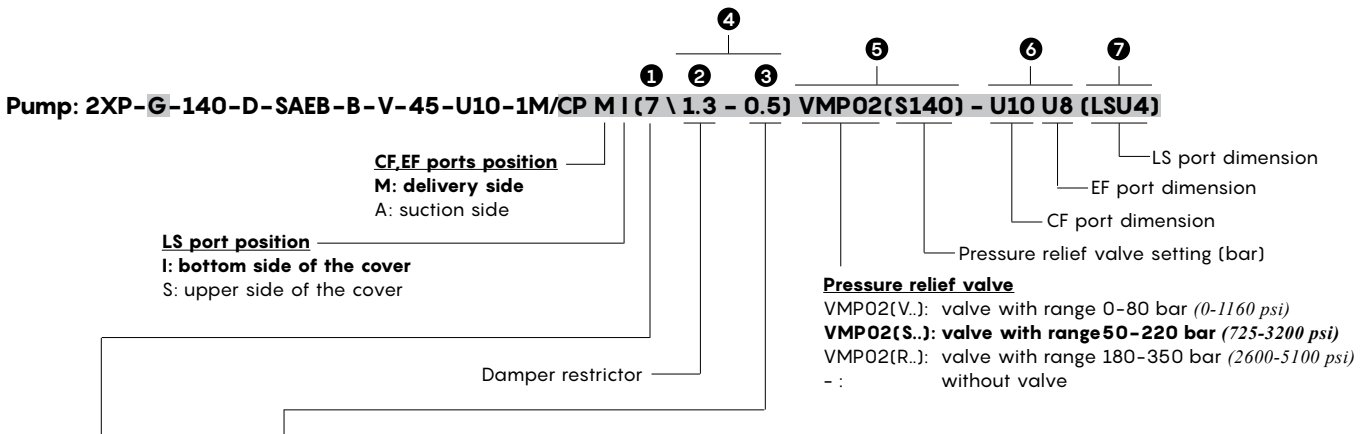

Spring type		Dynamic restrictor		Stand-by pressure value			
bar *	in	mm *	in	@ 5 l/min (1.32 US gpm)		@ 80 l/min (21.1 US gpm)	
				bar	psi	bar	psi
4	58	-	-	4	58	5.5	80
		<b>0.5</b>	0.019	5	72.5	7	102
		<b>0.6</b>	0.023	7	102	9	131
		<b>0.7</b>	0.027	8	116	11	160
7	102	-	-	7	102	9.5	138
		<b>0.5</b>	0.019	8.5	123	12	174
		<b>0.6</b>	0.023	12	174	15.5	225
		<b>0.7</b>	0.027	14.5	210	19	276
10	145	-	-	10	145	13	189
		<b>0.5</b>	0.019	13	189	16.5	239
		<b>0.6</b>	0.023	16.5	239	21.5	312
		<b>0.7</b>	0.027	20	290	25.5	370

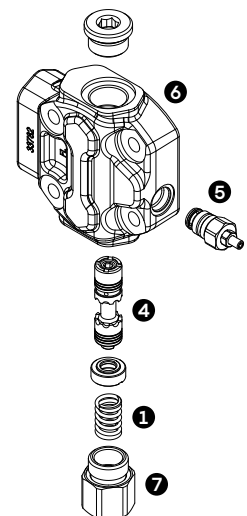

(\*): bold text is the reference for the description

## Special cover kits

### With priority valve

#### 6B - Cast iron type

Dimension example for Dynamic type with pressure relief valve:

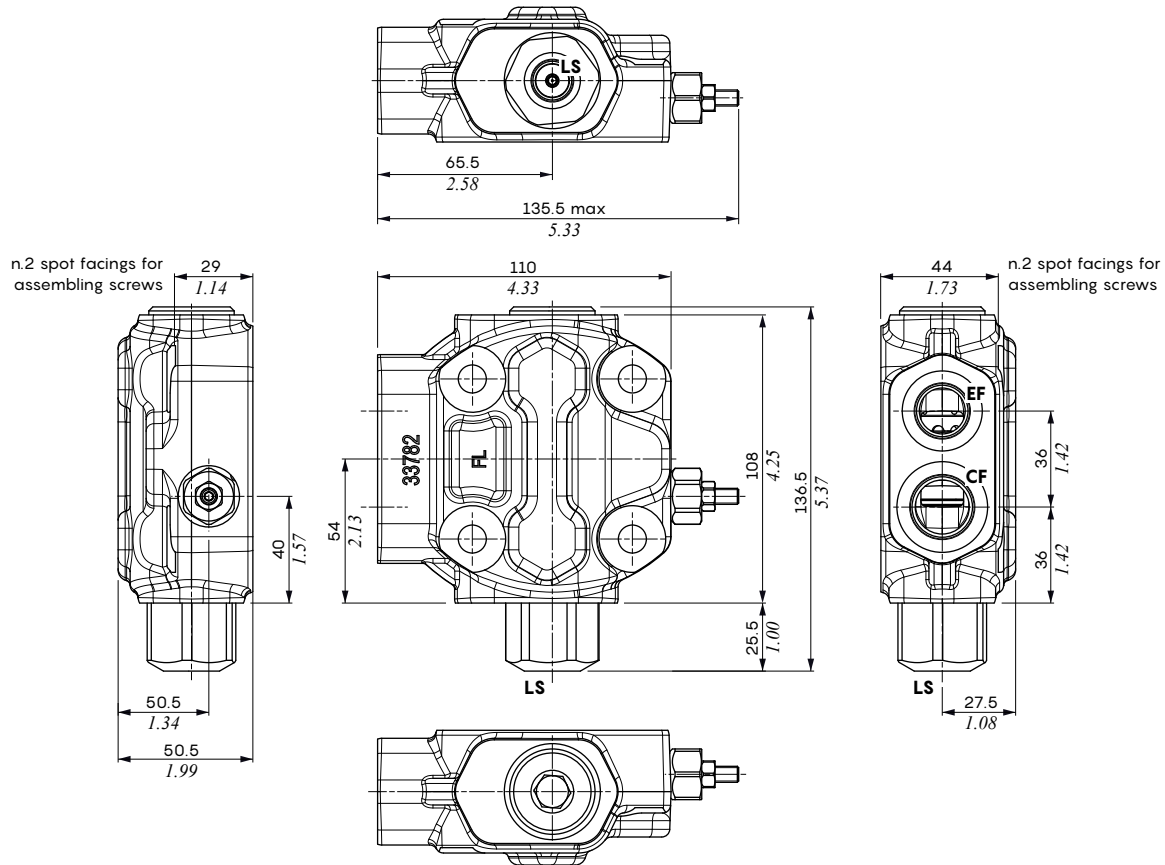

### Complete pump example

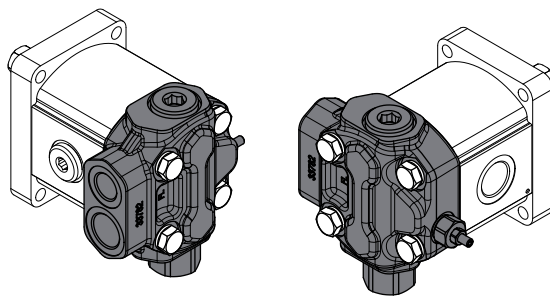

**With speed sensor**

These covers require dedicated driven gears.

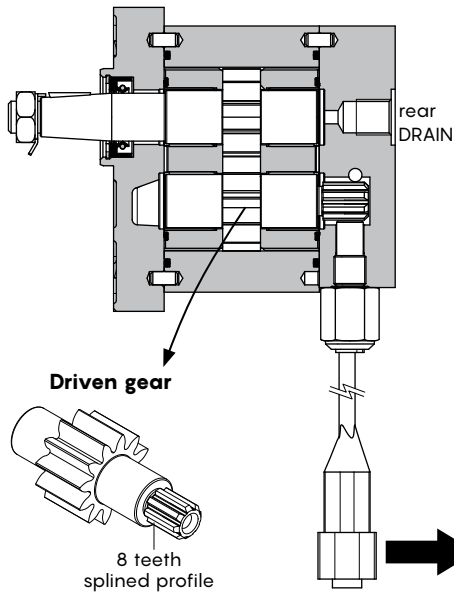

Driven gear shaft					
Displacement	Ordering codes	Displacement	Ordering codes	Displacement	Ordering codes
040	010053485999	140	010053486399	260	010053486799
060	010053486999	160	010053486499	290	010053486899
080	010053486199	190	010053486599	310	010053486999
110	010053486299	220	010053486699		

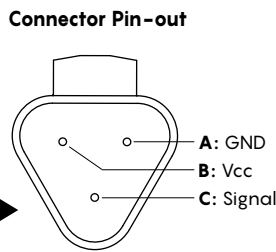

Speed sensor specifications	
Power supply	min. 4.5 V - max. 30 V
Max output current	25 mA
EMC compatibility (according to ISO11452-4 2005)	BCI - Class "C" - 100 mA 1 to 400 MHz
Output signal	Open Collector (NPN)
Environmental temperature for working conditions	from -40 to +150 °C (from -40 to +302 °F)
Max pressure (continuous)	400 bar (5800 psi)
Connector type	Deutsch DT04-3P
Tightening	wrench 19 - 24 Nm (17.7 lbf)

**6A - Aluminium type**

**Description example**

**Motor: 2XM-A-080-R-EUR-H-N-10-0-G12G12-SPS-DRENG14**

Available on	
2XP/2XM	2XPW/2XMW
•	-

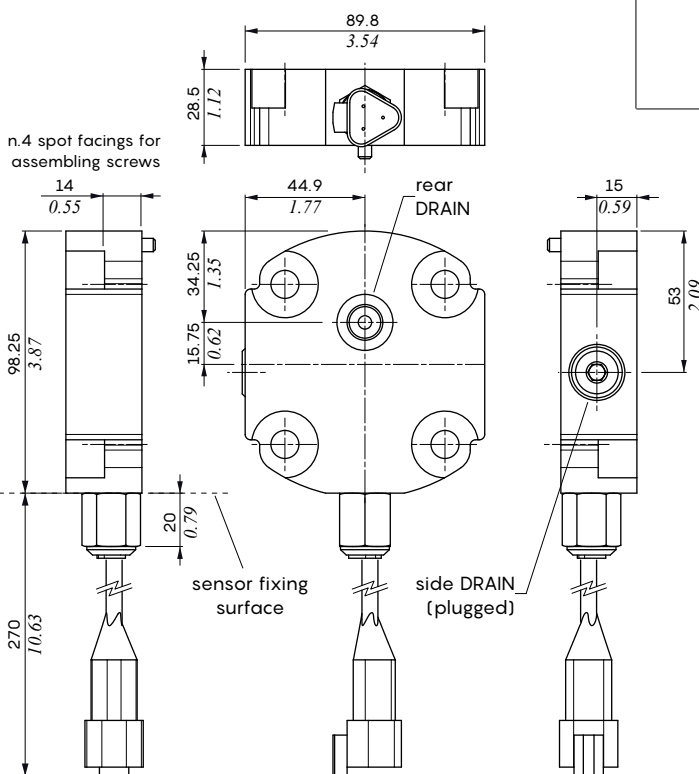

**Drain port**  
**DRENG14:** G1/4 port  
**DRENU6:** SAE6 port  
 Speed sensor

Ordering codes				
Pump/motor connection pos.	Ports code "G" (BSP threading)			
	CODE	IN	OUT	DRAIN**
0...SPS-DRENG14	5GKC2G204	-	-	G14
Pump/motor connection pos.	Ports code "U" (UN-UNF threading)			
	CODE	IN	OUT	DRAIN**
0...SPS-DRENU6	on request	-	-	U6

NOTE (\*\*): plug the DRAIN port in case of pump or unidirectional motor

## Special cover kits

### With speed sensor

#### 6B - Cast iron type

Pumps/motors with cast iron covers require UNI 5931 screws; for screws kit see page

#### Description example

Motor: **2XMW-G-080-R-EUR-H-N-10-0-G12G12-SPS-DRENG14 <CVN>**

Available on	
2XP/2XM	2XPW/2XMW
•	•

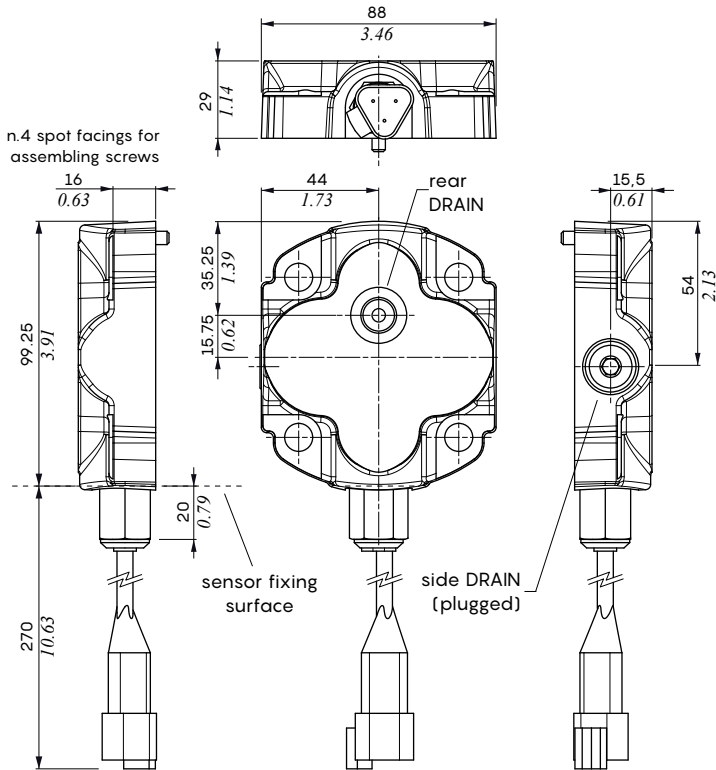

Ordering codes				
Pump/motor connection pos.	Ports code "G" (BSP threading)			
	CODE	IN	OUT	DRAIN**
O...DREN...SPS	5GKC2G218	-	-	G14
Pump/motor connection pos.	Ports code "U" (UN-UNF threading)			
	CODE	IN	OUT	DRAIN**
O...DREN...SPS	-	-	-	U6

NOTE (\*\*): plug the DRAIN port in case of pump or unidirectional motor



## Tandem pumps general informations

Walvoil allows tandem kit assembly in several different conditions.

As general indications :

- It is necessary to assemble the units from the largest to the smallest, in terms of power and torque required;
- Maximum rotation speed of multiple pump is equal to the unit with lowest maximum admissible speed;
- The maximum rotation speed of the multiple pump is equal to the unit with the lowest allowable maximum speed

When using and sizing a tandem pump there are three key points to consider

### 1) Torque

Each tandem kit allows the transmission of maximum torque between stages. .

It is important to check that the maximum transmitted torque remains below the value allowed by each tandem kit and main shaft.

The torque M of each stage can be calculated with the formula:

$$M = \frac{\Delta p \cdot V}{62.83 \cdot \eta_m}$$

When  $\Delta p$  is the maximum pressure created by the circuit on each stage, V is the displacement and  $\eta_m$  is the mechanical efficiency.

As example consider a triple pump with shaft type 30

2XP160/TK/2XP080/TK/2XP060.

The maximum pressure peaks that the system can produce at the same time are: 150 bar (2150 psi) , 180 bar (2600 psi), 120 bar (1750 psi)

In this working condition each required torque must be evaluated (an efficiency of 90% is considered).

Stage type	Working pressure		Torque		
	bar	psi	Formula	Nm	lbft
2XP160	150	2150	$M1 = \frac{150 \cdot 16}{62.83 \cdot 0.9}$	42.4	31.3
2XP80	180	2600	$M2 = \frac{180 \cdot 8}{62.83 \cdot 0.9}$	25.5	18.8
2XP60	120	1750	$M3 = \frac{120 \cdot 6}{62.83 \cdot 0.9}$	12.7	9.4

The main shaft shall transmit a torque **M1+M2+M3** (80.6 Nm - 59.5 lbft) which must be lower than the limit of shaft type 30 (180 Nm - 133 lbft).  
The first tandem kit shall transmit a torque **M2+M3** (38.2 Nm - 28.2 lbft) which shall be lower than the limit of the kit TK (100 Nm - 73.8 lbft); in this case it is acceptable.

The second tandem kit shall transmit a torque **M3** (12.7 Nm - 9.4 lbft) which shall be lower than the limit of the kit TK (100 Nm - 73.8 lbft); in this case it is acceptable.

### 2) Suction

The tandem is always possible with separate suction; in this case each pump uses its own suction pipe.

A common suction feature is available with Walvoil gear pumps.

In the case of common suction, two main conditions must be met.

- Sizing of the common inlet.

In the suction pipe it is recommended to have a cross section that ensures an oil speed between 0.6 and 2 m/s.

- Internal connection between stages

Each kit has a recommended maximum flow.

For example, the **2XP+2XP** double stage pump with **TK** tandem kit allows a max flow of 24 l/min (6.3 US gpm) shared between the stages.

This value is provided for each tandem kit and is valid under recommended service conditions.

In case one of the 2 above conditions is not met the pump can cavitate, reducing the life of the components.

### Tandem pumps general informations

#### 3) Stage with "drain" separation (separate stages tandem)

In a tandem pump the internal drain can be common or separate.

A common internal drain minimizes the size of the tandem but does not prevent oil from mixing between stages

The common drain connection cannot be applied when the pump has to operate with different types of oils.

For each application it is important to define if the oil can be mixed inside the pumps.

Example:

#### TK tandem kit, 2XP+2XP common drain pumps

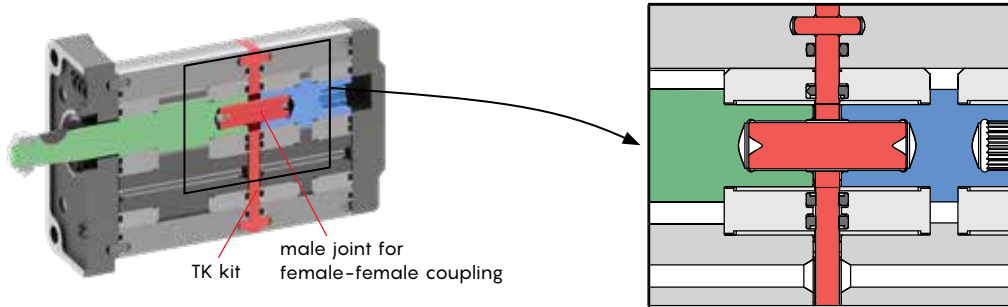

#### TCS tandem kit, 2XP+2XP separate drain pumps

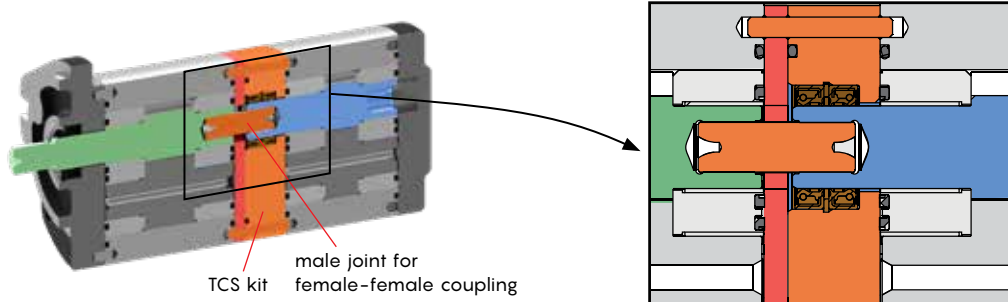

**Tandem kits - list and specifications**

**2XP or 2XPW primary stage**

Xtreme Series pumps can be used as primary stage with Group 1 secondary stage.

2X_ + 1S tandem kits										
Primary stage + Secondary stage	Kit type	CODE	Common suction compliant	Max. suction flow between stages		Max. transmitted torque		Drain connection	2 <sup>nd</sup> stage shaft type	Note
				l/min	US gpm	Nm	lbft			
2XP+1SP	TC	5GKTC21X1	No	-	-	30	22	Yes	18	Kit fitted with Group 1 aluminium special EUR flange
	TS	5GKTS2110	No	-	-	30	22	No	10	This kit requires 1SP secondary stage complete pump with EUR flange
2XP+1XP	TK	5GKTK2110	Yes	16.5	4.4	30	22	Yes	18F	This kit requires special 1XP body kit; type CR2P. Contact Sales Department

Xtreme Series pumps can be used as primary and secondary stages.

2X_ + 2X_ tandem kits										
Primary stage + Secondary stage	Kit type	CODE	Common suction compliant	Max. suction flow between stages		Max. torque between stages		Drain connection	2 <sup>nd</sup> stage shaft type	Note
				l/min	US gpm	Nm	lbft			
2XP+2XP	TK	5GKTK2200	Yes	24	6,3	100	73.8	Yes	18F	
	TCS	5GKTK2201	No	-	-	100	73.8	No	18L	
	TS	5GKTS2210	No	-	-	80	59	No	10	This kit requires 2XP secondary stage complete pump with EUR flange
	VD	-	Yes						18F	Kit for hi-low pressure tandem pump, fitted with unloader valve. The kit cannot be ordered separately
2XPW+2XP	TK	5GKTK2200	Yes	24	6,3	100	73.8	Yes	18F	
	TCS	5GKTK2201	No	-	-	100	73.8	No	18L	
2XPW+2XPW	TK	5GKTK2202	Yes	45	12	100	73.8	Yes	18F	
	TCS	5GKTK2201	No	-	-	100	73.8	No	18L	

**3GP primary stage, 2XP\_ secondary stage**

Xtreme Series pumps can be used as secondary stage with Group 3, type 3GP, as primary stage.

3GP + 2X_ tandem kits										
Primary stage + Secondary stage	Kit type	CODE	Common suction compliant	Max. suction flow between stages		Max. transmitted torque		Drain connection	2 <sup>nd</sup> stage shaft type	Note
				l/min	US gpm	Nm	lbft			
3GP+2XP	TC	5GKTC32X1	No	-	-	100	73.8	Yes	18F	Kit fitted with Group 2 aluminium EUR flange
	TS	5GKTS3200	No	-	-	100	73.8	No	10	This kit requires 2XP secondary stage complete pump with EUR flange

**3TPW primary stage, 2X\_ secondary stage**

Xtreme Series pumps can be used as secondary stage with Group 3, type 3TPW, as primary stage.

3TPW + 2X_ tandem kits										
Primary stage + Secondary stage	Kit type	CODE	Common suction compliant	Max. suction flow between stages		Max. transmitted torque		Drain connection	2 <sup>nd</sup> stage shaft type	Note
				l/min	US gpm	Nm	lbft			
3TPW(G2)+2XP	TN	5GKTN3200	No	-	-	100	73.8	Yes	18F	
3TPW(G2)+2XPW	TN	5GKTN3200	No	-	-	100	73.8	Yes	18F	
3TPW(G0D)+2XP	TK	5GKTK3200	No	-	-	100	73.8	Yes	18F	
3TPW(G0D)+2XPW	TK	5GKTK3200	No	-	-	100	73.8	Yes	18F	
	TKU	5GKTK3201	Yes	45	12	100	73.8	Yes	18F	

## Second stage dedicated driving gears

### Type 18F

This shaft is also used for flange with outboard bearings (SUP version).

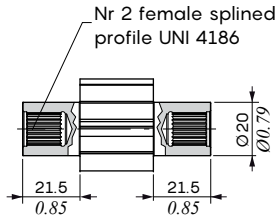

Max transmitted torque = 100 Nm - 74lbf<sub>t</sub>

Driving gear shaft kit			
Displacement	Ordering codes	Displacement	Ordering codes
040	5GKI2X0132*	190	5GKI2X0138
060	5GKI2X0133*	220	5GKI2X0139
080	5GKI2X0134*	260	5GKI2X0140
110	5GKI2X0135	290	5GKI2X0141
140	5GKI2X0136	310	5GKI2X0142
160	5GKI2X0137		

(\*) only for 2XP/2XM

### Type 18L

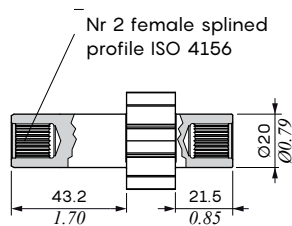

Max transmitted torque = 100 Nm - 74lbf<sub>t</sub>

Driving gear shaft kit			
Displacement	Ordering codes	Displacement	Ordering codes
040	010043472199*	190	010043472799
060	010043472299*	220	010043472899
080	010043472399*	260	010043472999
110	010043472499	290	010043473099
140	010043472599	310	010043473199
160	010043472699		

(\*) only for 2XP/2XM



### 2XP or 2XPW primary stage

#### 2XP+1SP - TS separate stages tandem dimension

This separate stages tandem is available if you have a complete 1SP pump with 1:8 tapered shaft and EUR flange.

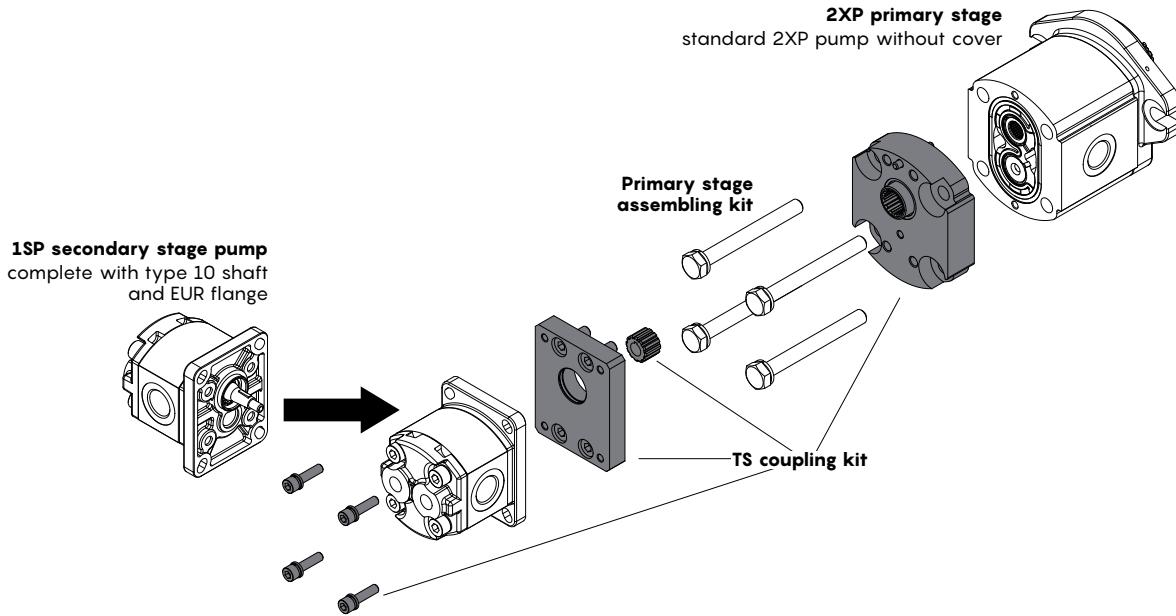

#### Description example

**2XP-A-110-D-EUR-B-N-10-0-G34G12/ TS /1SP-A-063-0-G38G38**

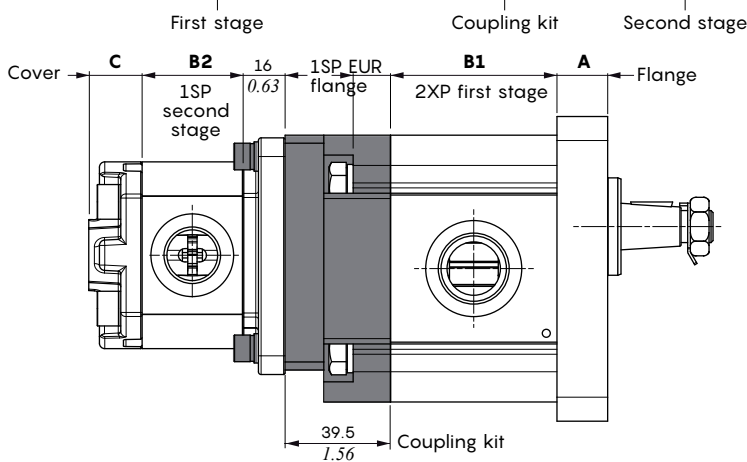

#### Hydraulic circuit

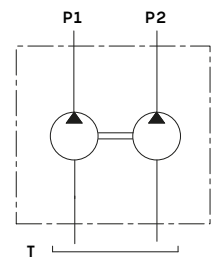

2XP flange			2XP body			1SP body			1SP cover		
Type	A		Displacement	B1		Displacement	B2		Port configuration	C	
	mm	in		mm	in		mm	in		mm	in
SAEA	19	0.75	040	50.8	2	009	37.6	1.48	0 / 2	20	0.79
SAEB	20	0.79	060	54.1	2.13	012	38.7	1.52			
EUR	19	0.75	080	58.3	2.29	016	40.4	1.59			
B80	21	0.83	110	62.4	2.46	020	41.9	1.65			
B50	18.8	0.74	140	67.4	2.65	025	43.9	1.73			
E52	16.3	0.64	160	71.6	2.82	032	46.6	1.83			
			190	76.6	3.01	037	48.6	1.91			
			220	81.6	3.21	042	50.5	1.99			
			260	87.4	3.44	050	53.6	2.11			
			290	90.7	3.57	063	58.7	2.31			
			310	95.8	3.77	078	64.4	2.54			
						098	72.3	2.85			

2XP or 2XPW primary stage

2XP+1XP - TK tandem dimension

This tandem is dedicated to common suction configuration and it is suitable for installations where the small size of the kit is crucial.

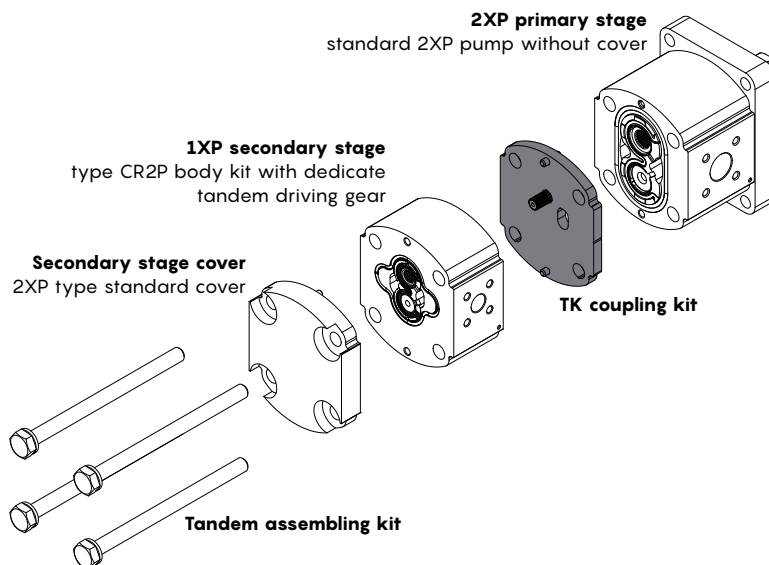

Description example

2XP-A-110-D-EUR-B-N-10-0-T20T15/ TK /1XP-A-032(CR2P)-0-T13T13

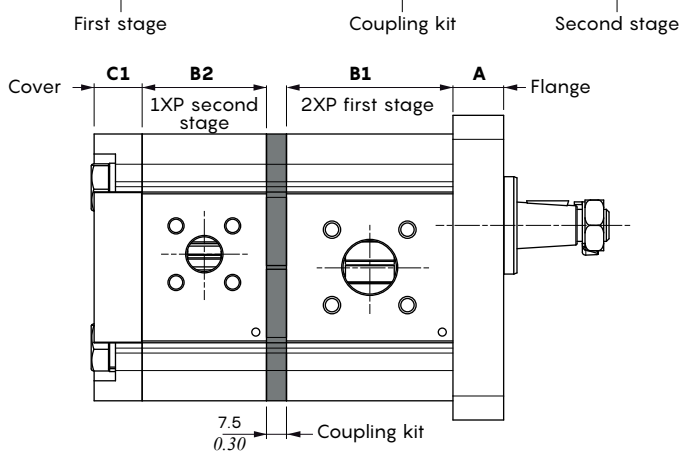

Hydraulic circuit

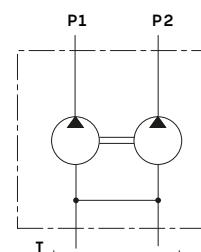

2XP flange			2XP body			1XP-CR2P body			2XP cover			
Type	A		Displacement	B1		Displacement	B2		Port configuration	C1		
	mm	in		mm	in		mm	in		mm	in	
SAEA	19	0.75	040	50.8	2	009	37.6	1.48	0	aluminium	20.5	0.81
SAEB	20	0.79	060	54.1	2.13	012	38.7	1.52		cast iron	18	0.71
EUR	19	0.75	080	58.3	2.29	016	40.4	1.59				
B80	21	0.83	110	62.4	2.46	020	41.9	1.65				
B50	18.8	0.74	140	67.4	2.65	025	43.9	1.73				
E52	16.3	0.64	160	71.6	2.82	032	46.6	1.83				
			190	76.6	3.01	037	48.6	1.91				
			220	81.6	3.21	042	50.5	1.99				
			260	87.4	3.44	050	53.6	2.11				
			290	90.7	3.57	063	58.7	2.31				
			310	95.8	3.77	078	64.4	2.54				
						098	72.3	2.85				

### 2XP or 2XPW primary stage

#### 2XP/2XPW - TK tandem dimensions

It is possible to combine the 2XP and 2XPW pumps to obtain different tandem configurations, with single and separate suction. The intermediate kit depends on configuration type; only 2XP stages, mixed or only 2XPW stages, as highlighted in the following drawings.

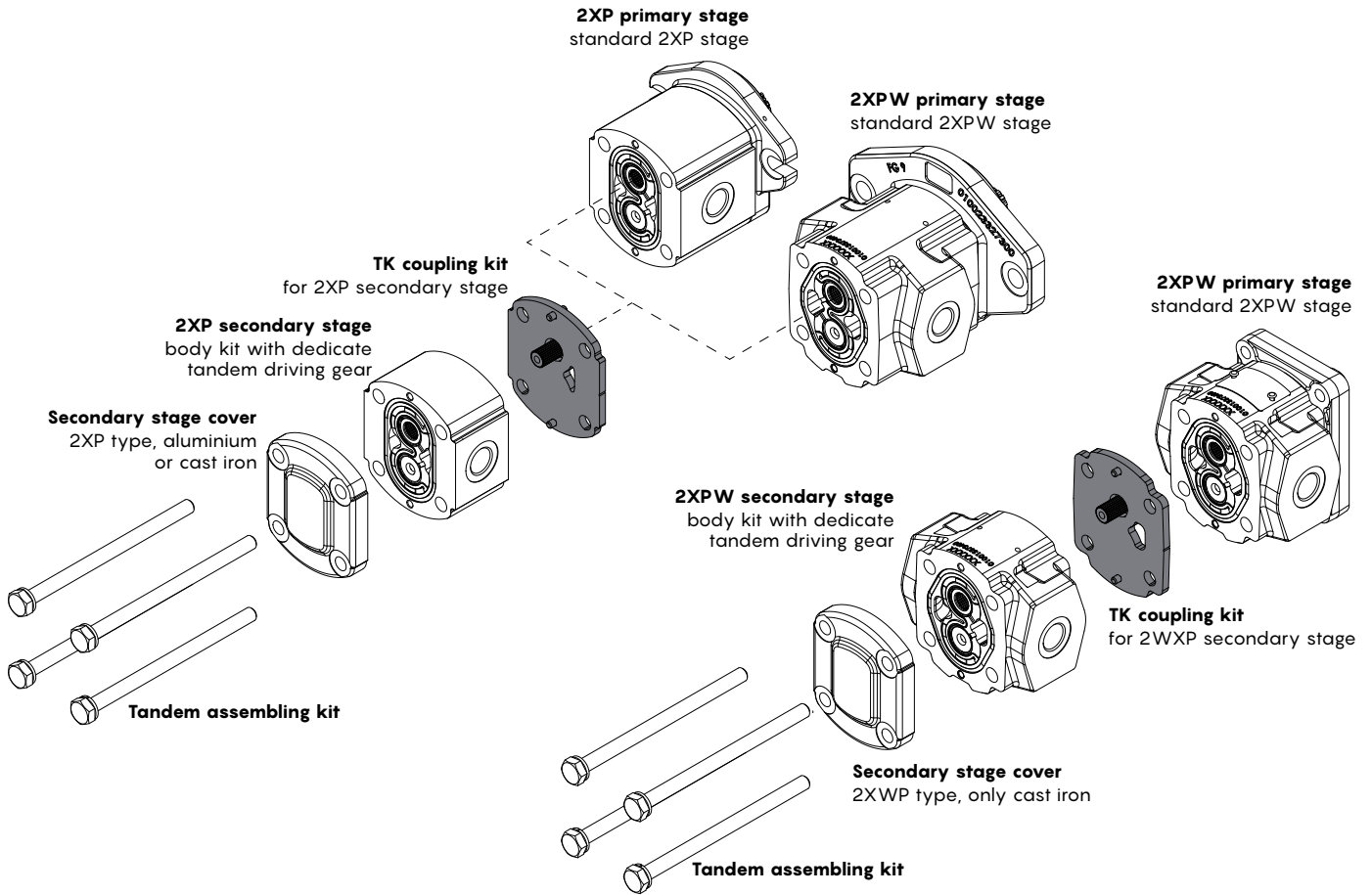

#### 2XP double stage description example

**2XP-G-190-D-SAEB-B-N-45-0U-G1G12/TK/2XP-G-040-0M-G12**

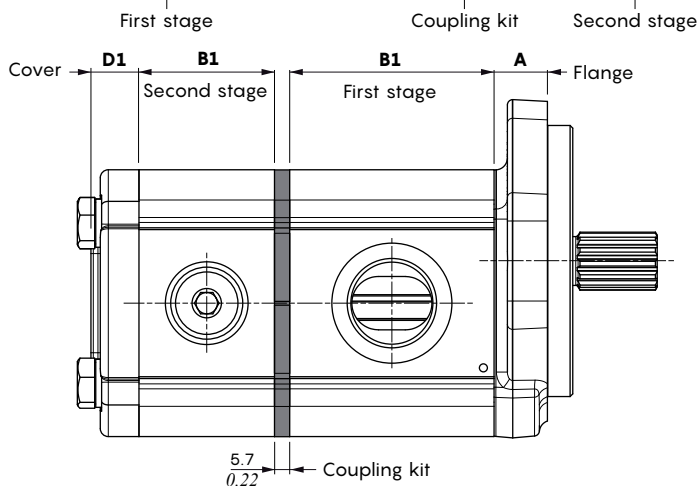

#### Hydraulic circuit

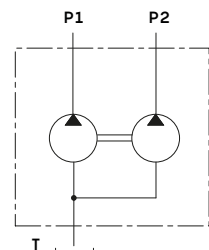



**2XP or 2XPW primary stage**

**2XP/2XPW - TK tandem dimensions**

**2XP three stages description example**

**2XP-A-260-D-EUR-B-N-10-0-G34G12/TK / 2XP-A-260-0U-G34G12/TK / 2XP-A-040-0M-G12**

First stage                      Coupling kit                      Second stage                      Coupling kit                      Third stage

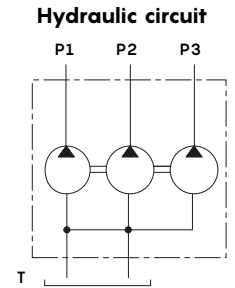
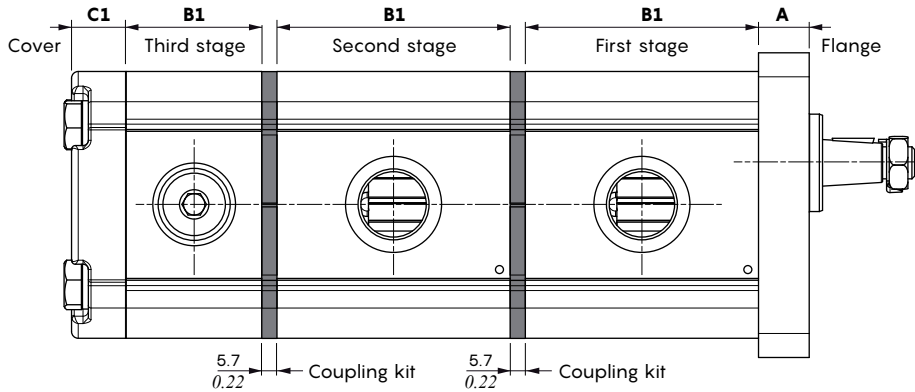

**2XPW+2XP double stage description example**

**2XPW-G-260-D-SAEB-B-N-45-0-G1G12/TK / 2XP-G-110-0-G34G12**

First stage                      Coupling kit                      Second stage

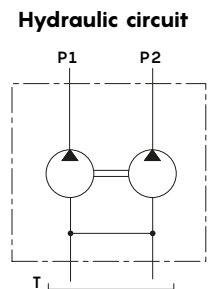
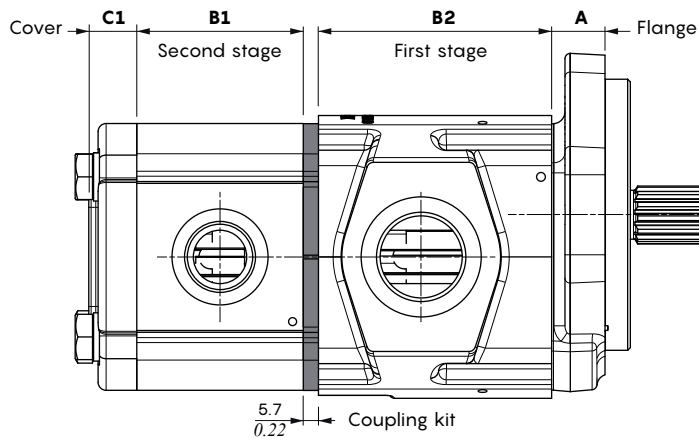

### 2XP or 2XPW primary stage

#### 2XP/2XPW - TK tandem dimensions

#### 2XPW double stage description example

**2XPW-G-190-D-EUR-B-N-10-0-G34G12/TK/2XPW-G-190-0-G34G12**

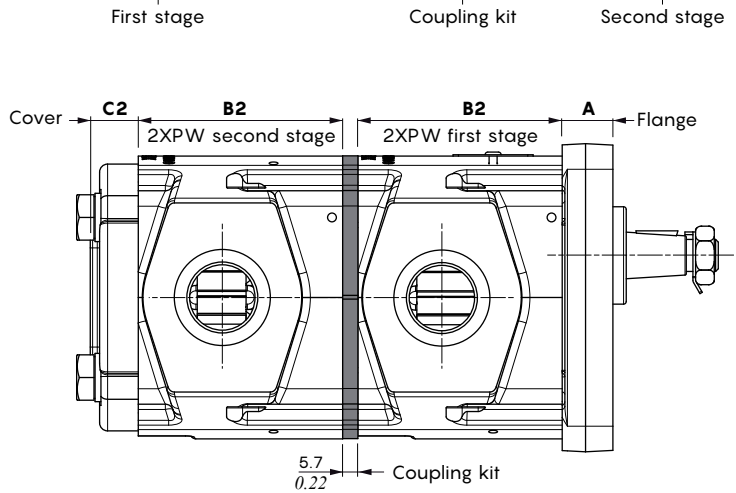

#### Hydraulic circuit

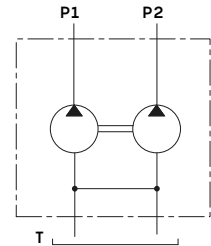

Flange			Body				Cover						
Type	A		Displacement	B1 (2XP)		B2 (2XPW)		Port configuration	C1 (2XP)		C2 (2XPW)		
	mm	in		mm	in	mm	in		mm	in	mm	in	
SAEA	19	0.75	040	50.8	2	-	-	0	aluminium	20.5	0.81	-	-
SAEB	20	0.79	060	54.1	2.13	-	-			cast iron	18	0.71	18
EUR	19	0.75	080	58.3	2.29	-	-						
B80	21	0.83	110	62.4	2.46	62.4	2.46						
B50	18.8	0.74	140	67.4	2.65	67.4	2.65						
E52	16.3	0.64	160	71.6	2.82	71.6	2.82						
			190	76.6	3.01	76.6	3.01						
			220	81.6	3.21	81.6	3.21						
			260	87.4	3.44	87.4	3.44						
			290	90.7	3.57	90.7	3.57						
			310	95.8	3.77	95.8	3.77						



### 2XP or 2XPW primary stage

#### 2XP/2XPW - VD tandem with unloader valve dimension

The hi-low pump is a double stage tandem pump fitted with a sequence valve on the intermediate flange.

When the pumps works at low pressure, the flows of the two pumps add up, allowing a rapid approaching or moving away of the actuator.

When the pressure exceeds the setting value of the sequence valve, the second pump's exhaust goes to the tank.

■ This pump has single suction and delivery: the suction has always to be at the second stage, while delivery has always to be at the first stage. Not all porting dimensions are available, the configurations must be checked with Technical Department.

■ The sequence valve can be set from 25 bar up to 100 bar (from 362 up to 1450 psi)

#### 2XP double stage description example

Rotation direction: Valve setting (bar)

**2XP-A-080-D-EUR-B-N-10-0M-G34 / VD(60) / 2XP-A-190-0U-G34**

First stage: Coupling kit with unloader valve: Second stage

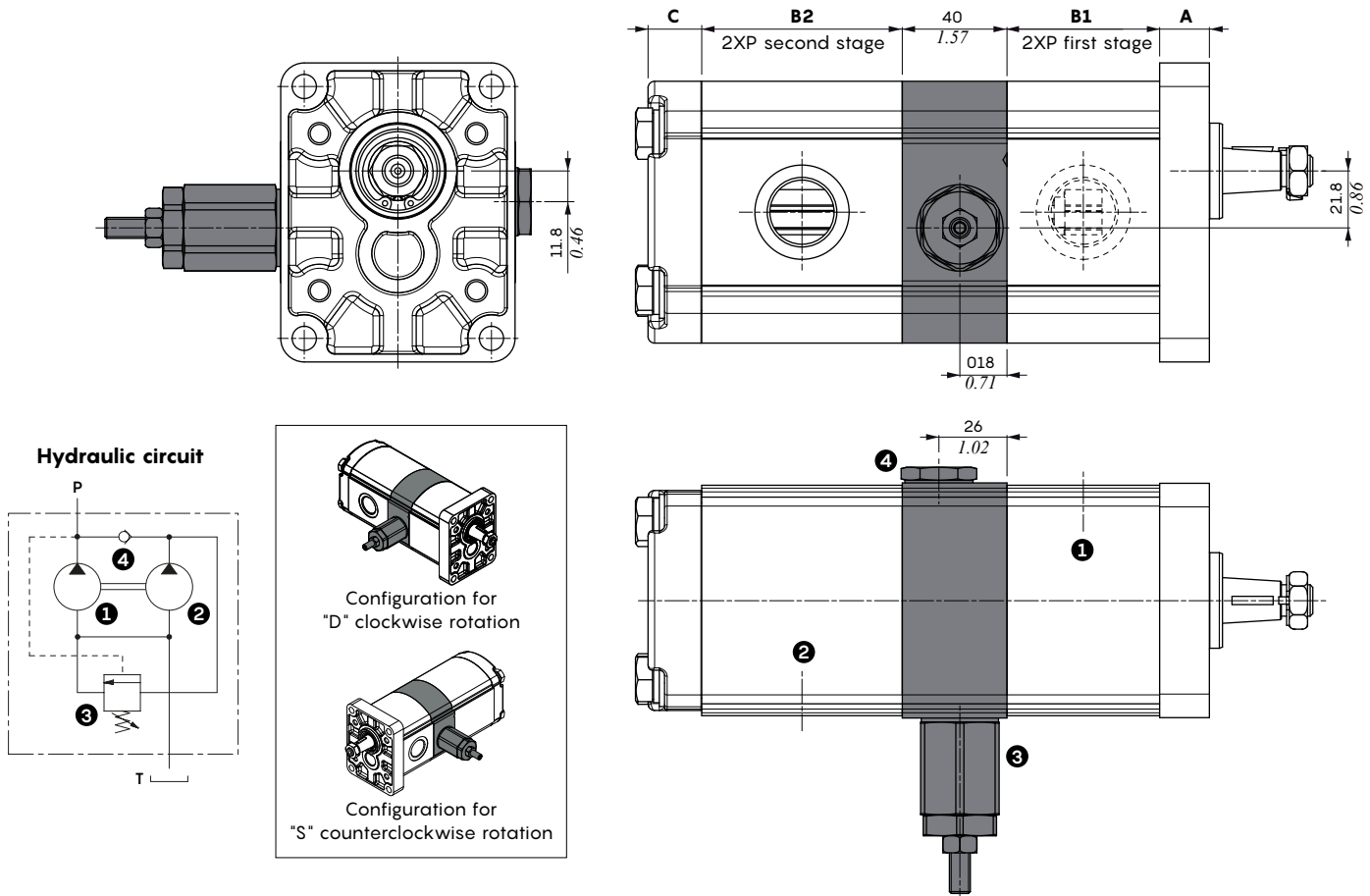

Flange			Body			Body			Cover			
Type	A		1 <sup>st</sup> stage displacement	B1		2 <sup>nd</sup> stage displacement	B2		Port configuration		C)	
	mm	in		mm	in		mm	in	mm	in		
SAEA	19	0.75	040	50.8	2	160	71.6	2.82	0	aluminium	20.5	0.81
SAEB	20	0.79	060	54.1	2.13	190	76.6	3.01		cast iron	18	0.71
EUR	19	0.75	080	58.3	2.29	220	81.6	3.21				
B80	21	0.83	110	62.4	2.46	260	87.4	3.44				
B50	18.8	0.74	140	67.4	2.65	290	90.7	3.57				
E52	16.3	0.64				310	95.8	3.77				



### Group 3 primary stage

#### 3GP+2XP - TC tandem dimension

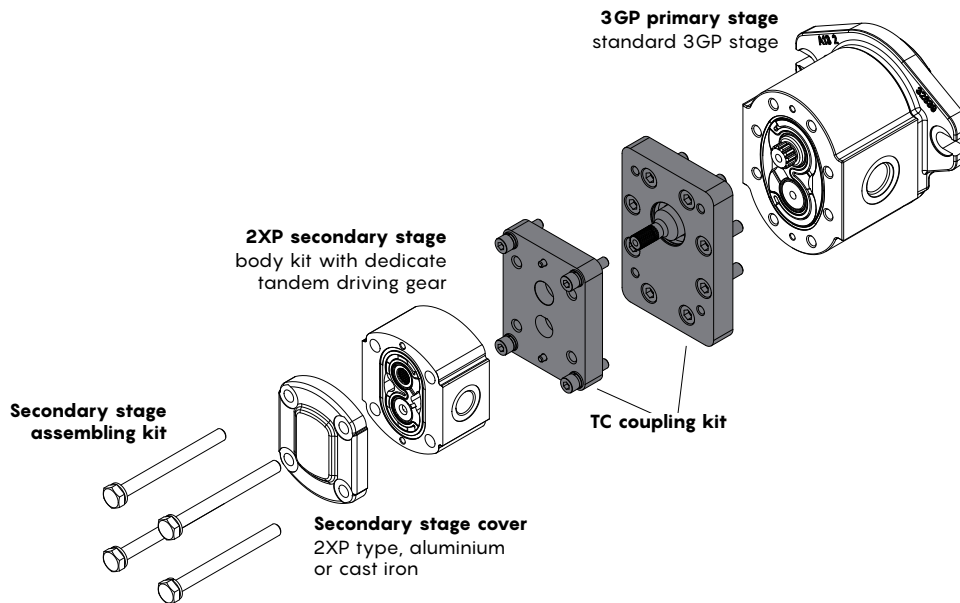

#### Description example

**3GP-G-300-D-SAEB-B-N-C15-0-T26T18/ TC /2XP-G-140-0-T20T15**

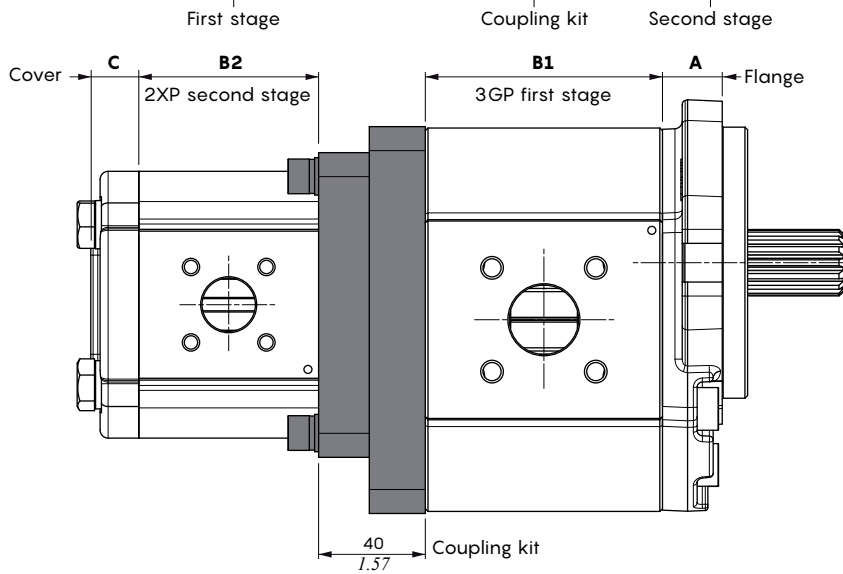

#### Hydraulic circuit

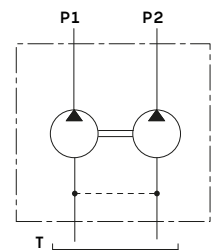

3GP flange			3GP body			2XP body			2XP cover			
Type	A		Displacement	B1		Displacement	B2		Port configuration		C	
	mm	in		mm	in		mm	in		mm	in	
SAEA	19	0.75	190	79.9	3.15	040	50.8	2	0	aluminium	20.5	0.81
SAEB	20	0.79	230	82.9	3.26	060	54.1	2.13		cast iron	18	0.71
EUR	19	0.75	300	88.9	3.5	080	58.3	2.29	1 / 3 / 4	aluminium	30	1.18
B80	21	0.83	340	91.9	3.62	110	62.4	2.46		cast iron	29	0.97
B50	18.8	0.74	370	94.9	3.74	140	67.4	2.65	0-ACS	cast iron	30	1.18
E52	16.3	0.64	440	100.9	3.97	160	71.6	2.82		0-SPS	aluminium	28.5
			530	107.9	4.25	190	76.6	3.01	cast iron		-	-
			620	115.9	4.56	220	81.6	3.21				
			700	122.4	4.82	260	87.4	3.44				
			770	127.9	5.04	290	90.7	3.57				
						310	95.8	3.77				



### Group 3 primary stage

#### 3TPW+2XP/2XPW - TN tandem dimensions

This tandem is available for separate suction configuration, and it consists of the first stage type 3TPW with G2 body and second stage type 2XP or 2XPW.

NOTE: In order to install TN coupling kit it's necessary to disassembly the 3TPW main shaft.

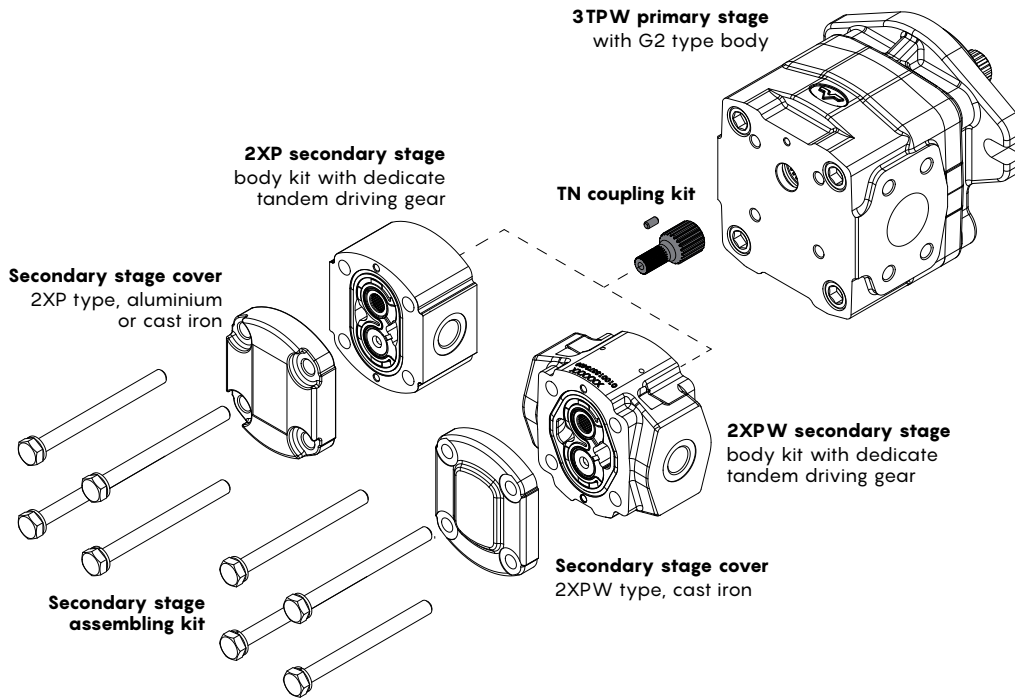

#### Separate suction description examples

**3TPW-G2-650-D-EUR2-B-N-10-OU-G114G1/2XP-A-140-0-G12G12**

First stage

Second stage

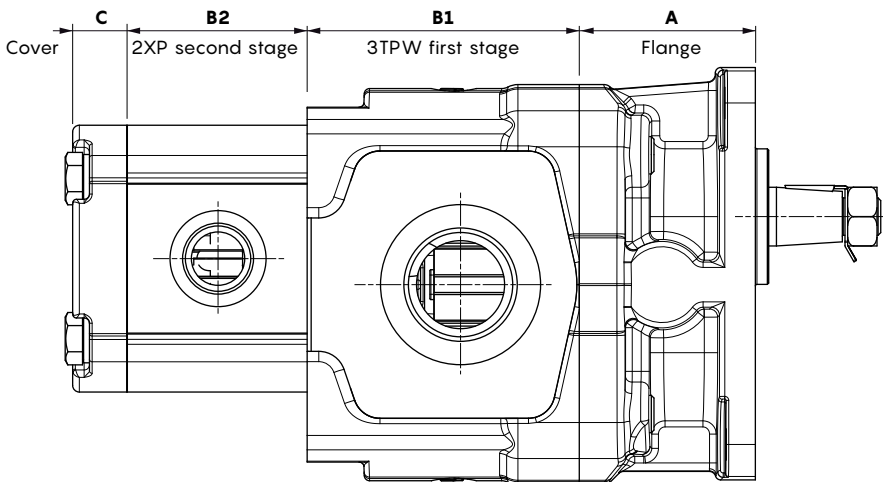

#### Hydraulic circuit

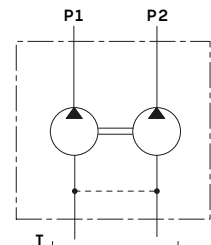



**3TPW+2XP/2XPW - TN tandem dimensions**

**Common suction description example**

**3TPW-G2U-650-D-EUR2-B-N-10-0U-G114G1/2XPW-G-140-0M-G12G12**

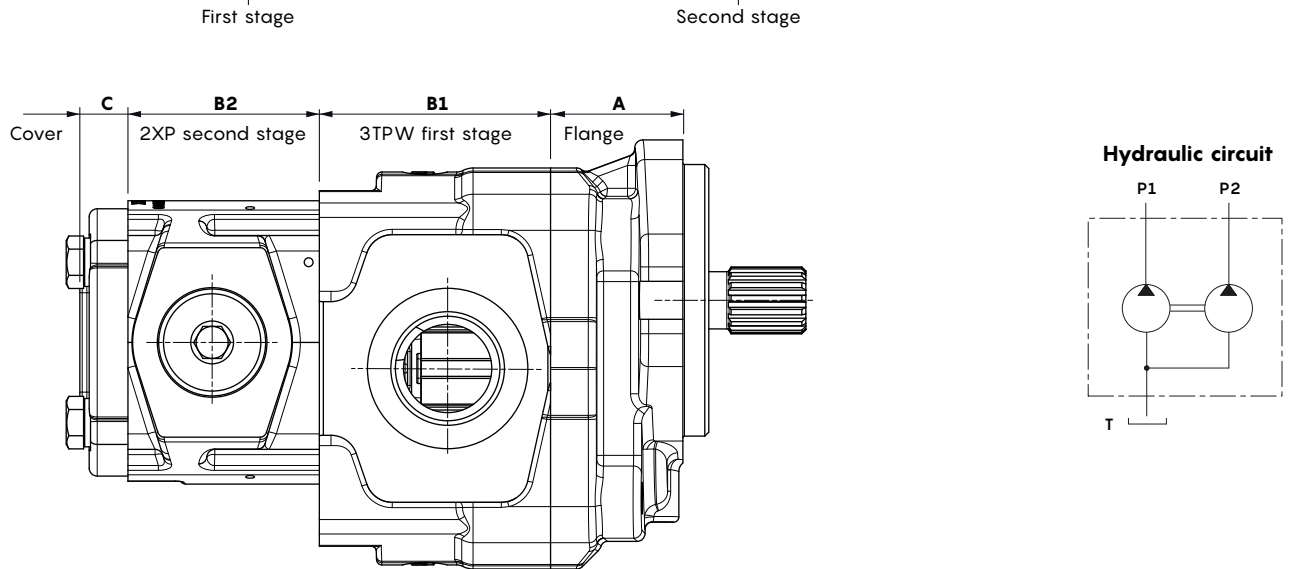

3TPW flange			3TPW-G2/G2U body			2XP/2XPW body				2XP/2XPW cover						
Type	A		Displacement	B1		Displacement	B2 (2XP)		B2 (2XPW)		Port configuration	C (2XP)		C (2XPW)		
	mm	in		mm	in		mm	in	mm	in		mm	in	mm	in	
SAEB	49.5	1.95	230	72	2.83	040	50.8	2	-	-	0	aluminium	20.5	0.81	-	-
SAEC-2F	49.5	1.95	280	75	2.99	060	54.1	2.13	-	-		cast iron	18	0.71	18	0.71
SAEC-4F	82	3.23	320	78	3.07	080	58.3	2.29	-	-	1 / 3 / 4	aluminium	30	1.18	-	-
EUR	66	2.60	390	83.5	15.35	110	62.4	2.46	62.4	2.46		cast iron	29	0.97	29	0.97
			430	86.5	3.41	140	67.4	2.65	67.4	2.65						
			470	89.5	3.52	160	71.6	2.82	71.6	2.82						
			520	92.5	3.64	190	76.6	3.01	76.6	3.01						
			560	96	3.78	220	81.6	3.21	81.6	3.21						
			600	99	3.90	260	87.4	3.44	87.4	3.44						
			650	102	4.02	290	90.7	3.57	90.7	3.57						
			710	107	4.21	310	95.8	3.77	95.8	3.77						
			790	113	4.45											

### Group 3 primary stage

#### 3TPW+2XP/2XPW Standard tandem dimensions

These tandems require G0D type body for 3TPW first stage and they can be configured for separate or common suction. Separate suction configuration requires a tandem consisting of the TK kit and second stage type 2XP or 2XPW. Common suction requires a tandem with TKU kit and second stage exclusively type 2XPW: max flow is 45 l/min (11.9 US gpm).

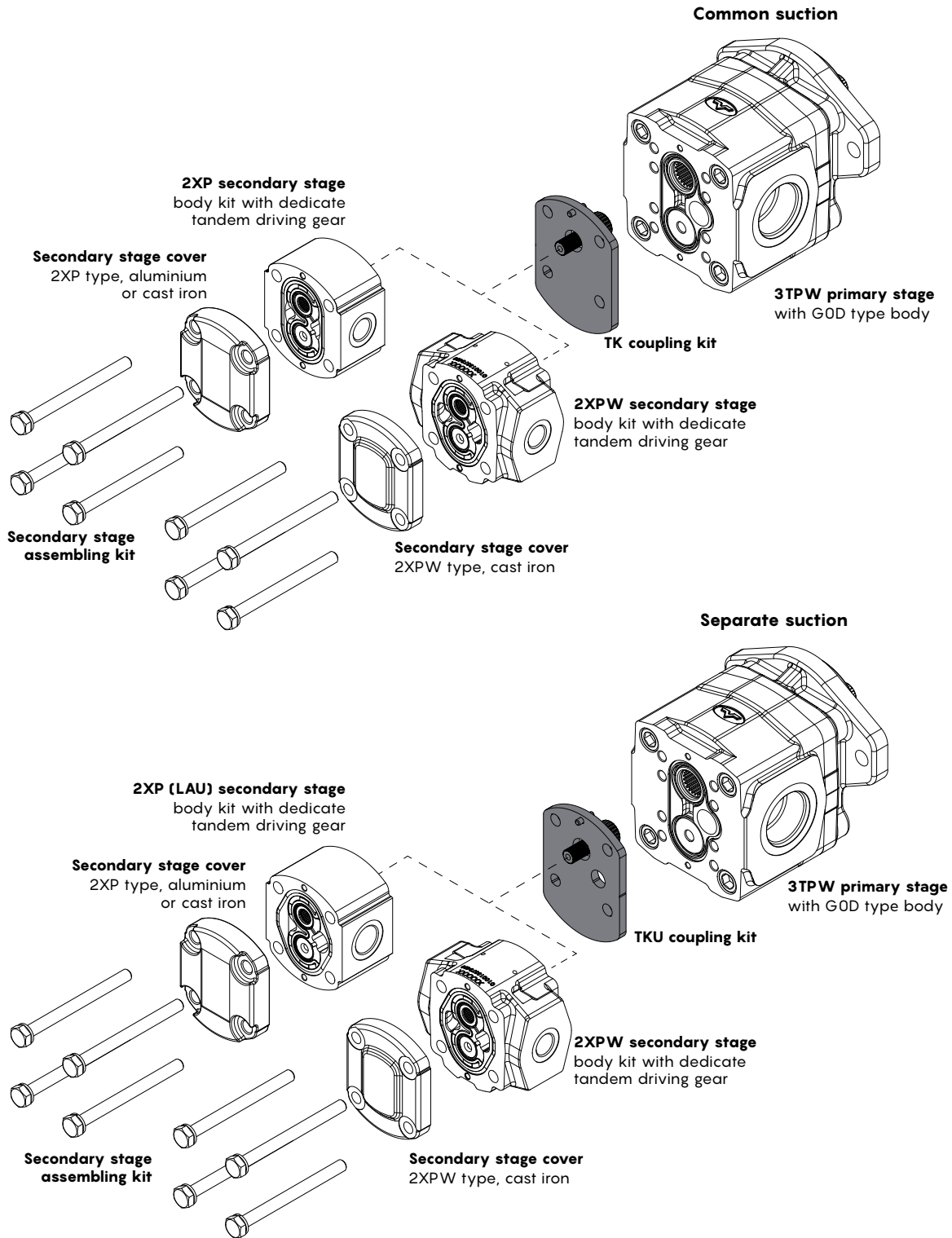

**3TPW+2XP/2XPW standard tandem dimensions**

**Separate suction description examples**

**3TPW-G0D-650-D-SAEB-B-N-10-0U-G114G1/ TK /2XP-A-140-0-N19N13**

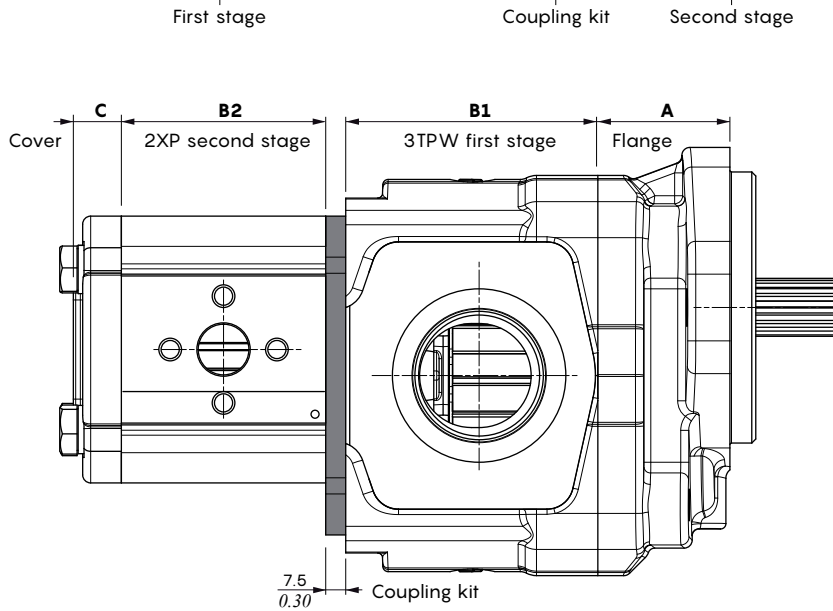

**Hydraulic circuit**

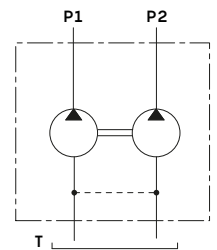

**Common suction description example**

**3TPW-G0D-650-D-SAEB-B-N-10-0U-G114G1/ TKU /2XPW-G-110-0M-G12**

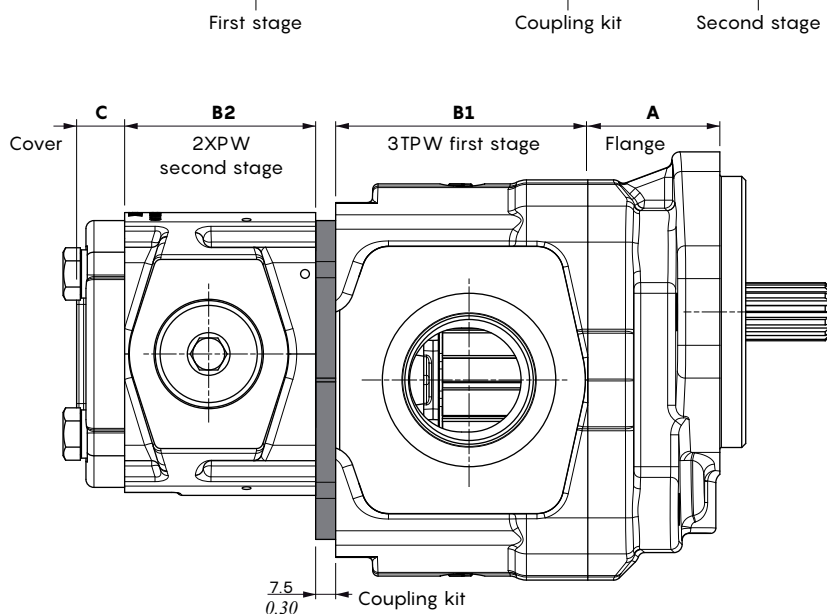

**Hydraulic circuit**

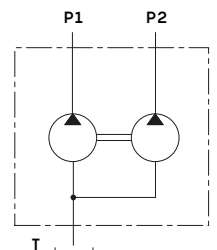

### Group 3 primary stage

#### 3TPW+2XP/2XPW standard tandem dimensions

3TPW flange			3TPW-GOD body			2XP/2XPW body				2XP/2XPW cover						
Type	A		Displacement	B1		Displacement	B2 (2XP)		B2 (2XPW)		Port configuration	C (2XP)		C (2XPW)		
	mm	in		mm	in		mm	in	mm	in		mm	in	mm	in	
SAEB	49.5	1.95	230	64.5	2.54	040	50.8	2	-	-	0	aluminium	20.5	0.81	-	-
SAEC-2F	49.5	1.95	280	67.5	2.66	060	54.1	2.13	-	-		cast iron	18	0.71	18	0.71
SAEC-4F	82	3.23	320	70.5	2.78	080	58.3	2.29	-	-	1 / 3 / 4	aluminium	30	1.18	-	-
EUR	66	2.60	390	76.0	2.99	110	62.4	2.46	62.4	2.46		cast iron	29	0.97	29	0.97
			430	79.0	3.11	140	67.4	2.65	67.4	2.65						
			470	82.0	3.23	160	71.6	2.82	71.6	2.82						
			520	85.0	3.35	190	76.6	3.01	76.6	3.01						
			560	88.5	3.48	220	81.6	3.21	81.6	3.21						
			600	91.5	3.60	260	87.4	3.44	87.4	3.44						
			650	94.5	3.72	290	90.7	3.57	90.7	3.57						
			710	99.5	3.92	310	95.8	3.77	95.8	3.77						
			790	105.5	4.15											

## Complete pumps ordering codes

2XP single stage aluminium pumps					
Flange type	Shaft type	Displacement	Code	Description	Notes
EUR	10	040	1GP20012429	2XP-A-040-D-EUR-B-N-10-0-G12G12	
		060	1GP20012570	2XP-A-060-D-EUR-B-N-10-0-G12G12	
		080	1GP20012483	2XP-A-080-D-EUR-B-N-10-0-G12G12	
		110	1GP20012373	2XP-A-110-D-EUR-B-N-10-0-G34G12	
		140	1GP20012290	2XP-A-140-D-EUR-B-N-10-0-G34G12	
		160	1GP20012302	2XP-A-160-D-EUR-B-N-10-0-G34G12	
		190	1GP20012572	2XP-A-190-D-EUR-B-N-10-0-G34G12	
		220	1GP20012981	2XP-A-220-D-EUR-B-N-10-0-G1G12	
		260	1GP20012982	2XP-A-260-D-EUR-B-N-10-0-G1G12	
		290	1GP20012980	2XP-A-290-D-EUR-B-N-10-0-G1G12	
		310	1GP20012979	2XP-A-310-D-EUR-B-N-10-0-G1G12	- Side BSP ports - NBR seals - Type B shaft sealing - Aluminium flange and cover
EUR	10	040	1GP20012292	2XP-A-040-D-EUR-B-N-10-0-N13N13	
		060	1GP20012293	2XP-A-060-D-EUR-B-N-10-0-N13N13	
		080	1GP20012294	2XP-A-080-D-EUR-B-N-10-0-N13N13	
		110	1GP20012295	2XP-A-110-D-EUR-B-N-10-0-N19N13	
		140	1GP20012296	2XP-A-140-D-EUR-B-N-10-0-N19N13	
		160	1GP20012297	2XP-A-160-D-EUR-B-N-10-0-N19N13	
		190	1GP20012289	2XP-A-190-D-EUR-B-N-10-0-N19N13	
		220	1GP20012298	2XP-A-220-D-EUR-B-N-10-0-N19N13	
		260	1GP20012299	2XP-A-260-D-EUR-B-N-10-0-N19N13	
		290	1GP20012457	2XP-A-290-D-EUR-B-N-10-0-N19N13	
		310	1GP20012300	2XP-A-310-D-EUR-B-N-10-0-N19N13	- Side N European flange ports - NBR seals - Type B shaft sealing - Aluminium flange and cover
SAEA	14	040	1GP20012525	2XP-A-040-D-SAEA-B-N-14-0-G12G12	
		060	1GP20012404	2XP-A-060-D-SAEA-B-N-14-0-G12G12	
		080	1GP20012408	2XP-A-080-D-SAEA-B-N-14-0-G12G12	
		110	1GP20012412	2XP-A-110-D-SAEA-B-N-14-0-G34G12	
		140	1GP20012526	2XP-A-140-D-SAEA-B-N-14-0-G34G12	
		160	1GP20012336	2XP-A-160-D-SAEA-B-N-14-0-G34G12	
		190	1GP20012423	2XP-A-190-D-SAEA-B-N-14-0-G34G12	
		220	1GP20012463	2XP-A-220-D-SAEA-B-N-14-0-G1G12	
		260	1GP20012464	2XP-A-260-D-SAEA-B-N-14-0-G1G12	
		290	1GP20012588	2XP-A-290-D-SAEA-B-N-14-0-G1G12	
		310	1GP20012466	2XP-A-310-D-SAEA-B-N-14-0-G1G12	- Side BSP ports - NBR seals - Type B shaft sealing - Aluminium flange and cover
SAEB	45	040	1GP20011946	2XP-G-040-D-SAEB-B-N-45-0-T20T15	
		060	1GP20011949	2XP-G-060-D-SAEB-B-N-45-0-T20T15	
		080	1GP20011950	2XP-G-080-D-SAEB-B-N-45-0-T20T15	
		110	1GP20011951	2XP-G-110-D-SAEB-B-N-45-0-T20T15	
		140	1GP20011914	2XP-G-140-D-SAEB-B-N-45-0-T20T15	
		160	1GP20011953	2XP-G-160-D-SAEB-B-N-45-0-T20T15	
		190	1GP20011954	2XP-G-190-D-SAEB-B-N-45-0-T20T15	
		220	1GP20011955	2XP-G-220-D-SAEB-B-N-45-0-T20T15	
		260	1GP20011956	2XP-G-040-D-SAEB-B-N-45-0-G12G12	- Side T german flange ports - NBR seals - Type B shaft sealing - Cast iron flange and cover
SAEB	45	040	1GP20012538	2XP-G-060-D-SAEB-B-N-45-0-G12G12	
		060	1GP20012539	2XP-G-080-D-SAEB-B-N-45-0-G12G12	
		080	1GP20012540	2XP-G-110-D-SAEB-B-N-45-0-G34G12	
		110	1GP20012388	2XP-G-140-D-SAEB-B-N-45-0-G34G12	
		140	1GP20012440	2XP-G-160-D-SAEB-B-N-45-0-G34G12	
		160	1GP20012441	2XP-G-190-D-SAEB-B-N-45-0-G34G12	
		190	1GP20012442	2XP-G-220-D-SAEB-B-N-45-0-G1G12	
		220	1GP20012669	2XP-G-260-D-SAEB-B-N-45-0-G1G12	
		260	1GP20012670	2XP-G-290-D-SAEB-B-N-45-0-G1G12	
		290	1GP20012671	2XP-G-310-D-SAEB-B-N-45-0-G1G12	
		310	1GP20012672	2XP-A-310-D-SAEA-B-N-14-0-G1G12	- Side BSP ports - NBR seals - Type B shaft sealing - Cast iron flange and cover

## Complete pumps ordering codes.

2XPW single stage cast iron pumps						
Flange type	Shaft type	Displacement	Code	Description	Notes	
EUR	10	110	1GP20012183	2XPW-G-110-D-EUR-B-N-10-0-G34G12-<CVN>		
		140	1GP20011923	2XPW-G-140-D-EUR-B-N-10-0-G34G12-<CVN>		
		160	1GP20011924	2XPW-G-160-D-EUR-B-N-10-0-G34G12-<CVN>		
		190	1GP20011925	2XPW-G-190-D-EUR-B-N-10-0-G34G12-<CVN>	- Side BSP ports - NBR seals - Type B shaft sealing	
		220	1GP20011926	2XPW-G-220-D-EUR-B-N-10-0-G1G12-<CVN>		
		260	1GP20011927	2XPW-G-260-D-EUR-B-N-10-0-G1G12-<CVN>		
		290	1GP20012184	2XPW-G-290-D-EUR-B-N-10-0-G1G12-<CVN>		
		310	1GP20011928	2XPW-G-310-D-EUR-B-N-10-0-G1G12-<CVN>		
SAEA	14	160	1GP20012325	2XPW-G-160-D-SAEA-B-N-14-0-G34G12-<CVN>		
		190	1GP20012326	2XPW-G-190-D-SAEA-B-N-14-0-G34G12-<CVN>		
		220	1GP20012327	2XPW-G-220-D-SAEA-B-N-14-0-G1G12-<CVN>	- Side BSP ports - NBR seals - Type B shaft sealing	
		260	1GP20012328	2XPW-G-260-D-SAEA-B-N-14-0-G1G12-<CVN>		
		290	1GP20012329	2XPW-G-290-D-SAEA-B-N-14-0-G1G12-<CVN>		
SAEB	45	110	1GP20012333	2XPW-G-110-D-SAEB-B-N-45-0-G34G12-<CVN>		
		140	1GP20012683	2XPW-G-140-D-SAEB-B-N-45-0-G34G12-<CVN>		
		160	1GP20012684	2XPW-G-160-D-SAEB-B-N-45-0-G34G12-<CVN>		
		190	1GP20012685	2XPW-G-190-D-SAEB-B-N-45-0-G34G12-<CVN>	- Side BSP ports - NBR seals - Type B shaft sealing	
		220	1GP20012686	2XPW-G-220-D-SAEB-B-N-45-0-G1G12-<CVN>		
		260	1GP20012687	2XPW-G-260-D-SAEB-B-N-45-0-G1G12-<CVN>		
		290	1GP20012690	2XPW-G-290-D-SAEB-B-N-45-0-G1G12-<CVN>		
		310	1GP20012692	2XPW-G-310-D-SAEB-B-N-45-0-G1G12-<CVN>		

## Complete motors ordering codes

2XM reversible aluminium motors					
motors	Shaft type	Displacement	Code	Description	Notes
EUR	10	040	1GM20013686	2XM-A-040-R-EUR-H-N-10-0-G12G12-DRENG14	
		060	1GM20013687	2XM-A-060-R-EUR-H-N-10-0-G12G12-DRENG14	
		080	1GM20013688	2XM-A-080-R-EUR-H-N-10-0-G12G12-DRENG14	
		110	1GM20013689	2XM-A-110-R-EUR-H-N-10-0-G34G34-DRENG14	- Side BSP ports
		140	1GM20013690	2XM-A-140-R-EUR-H-N-10-0-G34G34-DRENG14	- NBR seals
		160	1GM20013691	2XM-A-160-R-EUR-H-N-10-0-G34G34-DRENG14	- Type H shaft sealing
		190	1GM20011773	2XM-A-190-R-EUR-H-N-10-0-G34G34-DRENG14	- Aluminium flange and cover
		220	1GM20013692	2XM-A-220-R-EUR-H-N-10-0-G34G34-DRENG14	
		260	1GM20013693	2XM-A-260-R-EUR-H-N-10-0-G34G34-DRENG14	
EUR	10	040	1GM20011689	2XM-A-040-R-EUR-H-N-10-0-N13N13-DRENG14	
		060	1GM20011690	2XM-A-060-R-EUR-H-N-10-0-N13N13-DRENG14	
		080	1GM20011740	2XM-A-080-R-EUR-H-N-10-0-N13N13-DRENG14	
		110	1GM20011691	2XM-A-110-R-EUR-H-N-10-0-N19N19-DRENG14	- Side N European flange ports
		140	1GM20011741	2XM-A-140-R-EUR-H-N-10-0-N19N19-DRENG14	- NBR seals
		160	1GM20011742	2XM-A-160-R-EUR-H-N-10-0-N19N19-DRENG14	- Type H shaft sealing
		190	1GM20011693	2XM-A-190-R-EUR-H-N-10-0-N19N19-DRENG14	- Aluminium flange and cover
		220	1GM20011743	2XM-A-220-R-EUR-H-N-10-0-N19N19-DRENG14	
		260	1GM20011744	2XM-A-260-R-EUR-H-N-10-0-N19N19-DRENG14	

2XMW reversible cast iron motors					
Flange type	Shaft type	Displacement	Code	Description	Notes
EUR	10	110	1GM20013699	2XMW-G-110-R-EUR-H-N-10-0-G34G34-DRENG14<CVN>	
		140	1GM20013700	2XMW-G-140-R-EUR-H-N-10-0-G34G34-DRENG14<CVN>	
		160	1GM20013701	2XMW-G-160-R-EUR-H-N-10-0-G34G34-DRENG14<CVN>	
		190	1GM20013702	2XMW-G-190-R-EUR-H-N-10-0-G34G34-DRENG14<CVN>	- Side BSP ports
		220	1GM20013703	2XMW-G-220-R-EUR-H-N-10-0-G34G34-DRENG14<CVN>	- NBR seals
		260	1GM20013704	2XMW-G-260-R-EUR-H-N-10-0-G34G34-DRENG14<CVN>	- Type B shaft sealing
		290	1GM20013705	2XMW-G-290-R-EUR-H-N-10-0-G34G34-DRENG14<CVN>	
		310	1GM20013710	2XMW-G-310-R-EUR-H-N-10-0-G34G34-DRENG14<CVN>	
		EUR	10	110	1GM20011677
140	1GM20011678			2XMW-G-140-R-EUR-H-N-10-0-N19N19-DRENG14<CVN>	
160	1GM20011679			2XMW-G-160-R-EUR-H-N-10-0-N19N19-DRENG14<CVN>	- Side N European flange ports
190	1GM20011680			2XMW-G-190-R-EUR-H-N-10-0-N19N19-DRENG14<CVN>	- NBR seals
220	1GM20013711			2XMW-G-220-R-EUR-H-N-10-0-N19N19-DRENG14<CVN>	- Type H shaft sealing
260	on request			2XMW-G-260-R-EUR-H-N-10-0-N19N19-DRENG14<CVN>	
290	on request			2XMW-G-290-R-EUR-H-N-10-0-N19N19-DRENG14<CVN>	
310	on request			2XMW-G-310-R-EUR-H-N-10-0-N19N19-DRENG14<CVN>	
B80C	11			110	on request
		140	on request	2XMW-G-140-R-B80C-H-N-11-0-G34G34-DRENG14<CVN>	
		160	on request	2XMW-G-160-R-B80C-H-N-11-0-G34G34-DRENG14<CVN>	
		190	on request	2XMW-G-190-R-B80C-H-N-11-0-G34G34-DRENG14<CVN>	- Side BSP ports
		220	on request	2XMW-G-220-R-B80C-H-N-11-0-G34G34-DRENG14<CVN>	- NBR seals
		260	on request	2XMW-G-260-R-B80C-H-N-11-0-G34G34-DRENG14<CVN>	- Type H shaft sealing
		290	on request	2XMW-G-290-R-B80C-H-N-11-0-G34G34-DRENG14<CVN>	
		310	on request	2XMW-G-310-R-B80C-H-N-11-0-G34G34-DRENG14<CVN>	

## Secondary stages ordering codes

### 2XP aluminium body

The section kit is supplied complete with plastic protective flanges and plugs

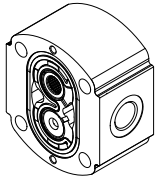

**Standard body section**

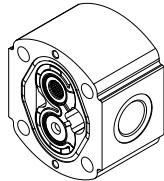

**LAU body type section**

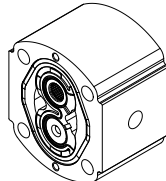

**SGR body type section**

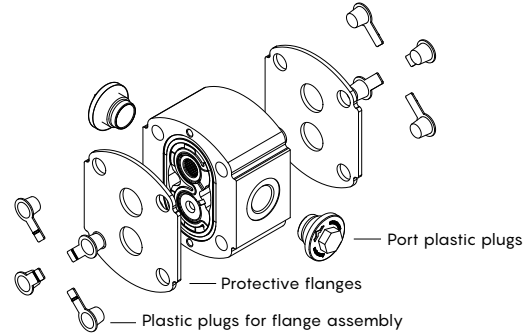

#### STANDARD body

Shaft type	Displacement	Code	Description	Notes
<b>Standard porting configurations</b>				
18F tandem shaft	040	5GKBP20097	SECTION 2XP-040-D-N-18F-0-G12G12	
	060	5GKBP20098	SECTION 2XP-060-D-N-18F-0-G12G12	
	080	5GKBP20165	SECTION 2XP-080-D-N-18F-0-G34G12	
	110	5GKBP20100	SECTION 2XP-110-D-N-18F-0-G34G12	
	140	5GKBP20101	SECTION 2XP-140-D-N-18F-0-G34G12	
	160	5GKBP20102	SECTION 2XP-160-D-N-18F-0-G34G12	
	190	5GKBP20103	SECTION 2XP-190-D-N-18F-0-G34G12	
	220	5GKBP20164	SECTION 2XP-220-D-N-18F-0-G1G12	- Side BSP ports
	260	5GKBP20163	SECTION 2XP-260-D-N-18F-0-G1G12	- NBR seals
	290	5GKBP20162	SECTION 2XP-290-D-N-18F-0-G1G12	
310	5GKBP20161	SECTION 2XP-310-D-N-18F-0-G1G12		
<b>Alternative porting configurations</b>				
	080	5GKBP20099	SECTION 2XP-080-D-N-18F-0-G12G12	
	220	5GKBP20104	SECTION 2XP-220-D-N-18F-0-G34G12	
	260	5GKBP20105	SECTION 2XP-260-D-N-18F-0-G34G12	
	290	5GKBP20106	SECTION 2XP-290-D-N-18F-0-G34G12	
	310	5GKBP20107	SECTION 2XP-310-D-N-18F-0-G34G12	
<b>Standard porting configurations</b>				
18F tandem shaft	040	5GKBP20134	SECTION-2XP-040-D-N-18F-0-U12U10	
	060	5GKBP20135	SECTION-2XP-060-D-N-18F-0-U12U10	
	080	5GKBP20136	SECTION-2XP-080-D-N-18F-0-U12U10	
	110	5GKBP20144	SECTION-2XP-110-D-N-18F-0-U12U10	
	140	5GKBP20143	SECTION-2XP-140-D-N-18F-0-U12U10	
	160	5GKBP20142	SECTION-2XP-160-D-N-18F-0-U12U10	
	190	5GKBP20141	SECTION-2XP-190-D-N-18F-0-U12U10	
	220	5GKBP20174	SECTION-2XP-220-D-N-18F-0-U16U10	- Side UN-UNF ports
	260	5GKBP20175	SECTION-2XP-260-D-N-18F-0-U16U10	- NBR seals
	290	5GKBP20177	SECTION-2XP-290-D-N-18F-0-U16U10	
310	5GKBP20176	SECTION-2XP-310-D-N-18F-0-U16U10		
<b>Alternative porting configurations</b>				
	220	5GKBP20140	SECTION-2XP-220-D-N-18F-0-U16U12	
	260	5GKBP20139	SECTION-2XP-260-D-N-18F-0-U16U12	
	290	5GKBP20138	SECTION-2XP-290-D-N-18F-0-U16U12	
	310	5GKBP20137	SECTION-2XP-310-D-N-18F-0-U16U12	



## Secondary stage ordering codes

### 2XP aluminium body

STANDARD body				
Shaft type	Displacement	Code	Description	Notes
18F tandem shaft	040	5GKBP20116	SECTION-2XP-060-D-N-18F-0-T20T15	
	060	5GKBP20117	SECTION-2XP-040-D-N-18F-0-T20T15	
	080	5GKBP20119	SECTION-2XP-080-D-N-18F-0-T20T15	
	110	5GKBP20120	SECTION-2XP-110-D-N-18F-0-T20T15	
	140	5GKBP20121	SECTION-2XP-140-D-N-18F-0-T20T15	
	160	5GKBP20122	SECTION-2XP-160-D-N-18F-0-T20T15	- Side T german flange ports - NBR seals
	190	5GKBP20160	SECTION 2XP-190-D-N-18F-0-T20T15	
	220	5GKBP20159	SECTION 2XP-220-D-N-18F-0-T20T15	
	260	5GKBP20158	SECTION 2XP-260-D-N-18F-0-T20T15	
	290	5GKBP20157	SECTION 2XP-290-D-N-18F-0-T20T15	
	310	5GKBP20156	SECTION 2XP-310-D-N-18F-0-T20T15	
18F tandem shaft	040	5GKBP20072	SECTION 2XP-040-D-N-18F-0-N13N13	
	060	5GKBP20073	SECTION 2XP-060-D-N-18F-0-N13N13	
	080	5GKBP20074	SECTION 2XP-080-D-N-18F-0-N13N13	
	110	5GKBP20075	SECTION 2XP-110-D-N-18F-0-N19N13	
	140	5GKBP20076	SECTION 2XP-140-D-N-18F-0-N19N13	
	160	5GKBP20077	SECTION 2XP-160-D-N-18F-0-N19N13	- Side N European flange ports - NBR seals
	190	5GKBP20078	SECTION 2XP-190-D-N-18F-0-N19N13	
	220	5GKBP20079	SECTION 2XP-220-D-N-18F-0-N19N13	
	260	5GKBP20080	SECTION 2XP-260-D-N-18F-0-N19N13	
	290	5GKBP20166	SECTION 2XP-290-D-N-18F-0-N19N13	
	310	5GKBP20081	SECTION 2XP-310-D-N-18F-0-N19N13	

## Secondary stage ordering codes

### 2XP aluminium body

The section kit is supplied complete with plastic protective flanges and plugs

LAU body type				
Shaft type	Displacement	Code	Description	Notes
18F tandem shaft	040	5GKBP20180	SECTION 2XP-040(LAU)-D-N-18F-0-G34G12	
	060	5GKBP20181	SECTION 2XP-060(LAU)-D-N-18F-0-G34G12	
	080	5GKBP20182	SECTION 2XP-080(LAU)-D-N-18F-0-G34G12	
	110	5GKBP20183	SECTION 2XP-110(LAU)-D-N-18F-0-G34G12	
	140	5GKBP20184	SECTION 2XP-140(LAU)-D-N-18F-0-G34G12	
	160	5GKBP20185	SECTION 2XP-160(LAU)-D-N-18F-0-G34G12	- Side BSP ports - NBR seals
	190	5GKBP20186	SECTION 2XP-190(LAU)-D-N-18F-0-G34G12	
	220	5GKBP20187	SECTION 2XP-220(LAU)-D-N-18F-0-G1G12	
	260	5GKBP20188	SECTION 2XP-260(LAU)-D-N-18F-0-G1G12	
	290	5GKBP20190	SECTION 2XP-290(LAU)-D-N-18F-0-G1G12	
	310	5GKBP20191	SECTION 2XP-310(LAU)-D-N-18F-0-G1G12	
18F tandem shaft	040	5GKBP20192	SECTION 2XP-040(LAU)-D-N-18F-T20T15	
	060	5GKBP20193	SECTION 2XP-060(LAU)-D-N-18F-T20T15	
	080	5GKBP20194	SECTION 2XP-080(LAU)-D-N-18F-T20T15	
	110	5GKBP20195	SECTION 2XP-110(LAU)-D-N-18F-T20T15	
	140	5GKBP20196	SECTION 2XP-140(LAU)-D-N-18F-T20T15	
	160	5GKBP20197	SECTION 2XP-160(LAU)-D-N-18F-T20T15	- Side T german flange ports - NBR seals
	190	5GKBP20198	SECTION 2XP-190(LAU)-D-N-18F-T20T15	
	220	5GKBP20199	SECTION 2XP-220(LAU)-D-N-18F-T20T15	
	260	5GKBP20200	SECTION 2XP-260(LAU)-D-N-18F-T20T15	
	290	5GKBP20201	SECTION 2XP-290(LAU)-D-N-18F-T20T15	
	310	5GKBP20202	SECTION 2XP-310(LAU)-D-N-18F-T20T15	

SGR body type				
Shaft type	Displacement	Code	Description	Notes
18F tandem shaft	040	5GKBP20145	SECTION 2XP-040(SGR)-D-N-18F-0-B13B13	
	060	5GKBP20146	SECTION 2XP-060(SGR)-D-N-18F-0-B13B13	
	080	5GKBP20147	SECTION 2XP-080(SGR)-D-N-18F-0-B13B13	
	110	5GKBP20148	SECTION 2XP-110(SGR)-D-N-18F-0-B19B13	
	140	5GKBP20149	SECTION 2XP-140(SGR)-D-N-18F-0-B19B13	
	160	5GKBP20150	SECTION 2XP-160(SGR)-D-N-18F-0-B19B13	- Side ports arrangement - NBR seals
	190	5GKBP20151	SECTION 2XP-190(SGR)-D-N-18F-0-B19B13	
	220	5GKBP20152	SECTION 2XP-220(SGR)-D-N-18F-0-B19B13	
	260	5GKBP20153	SECTION 2XP-260(SGR)-D-N-18F-0-B19B13	
	290	5GKBP20154	SECTION 2XP-290(SGR)-D-N-18F-0-B19B13	
	310	5GKBP20155	SECTION 2XP-310(SGR)-D-N-18F-0-B19B13	

## Secondary stage ordering codes

### 2XPW cast iron body

The section kit is supplied complete with plastic protective flanges and plugs

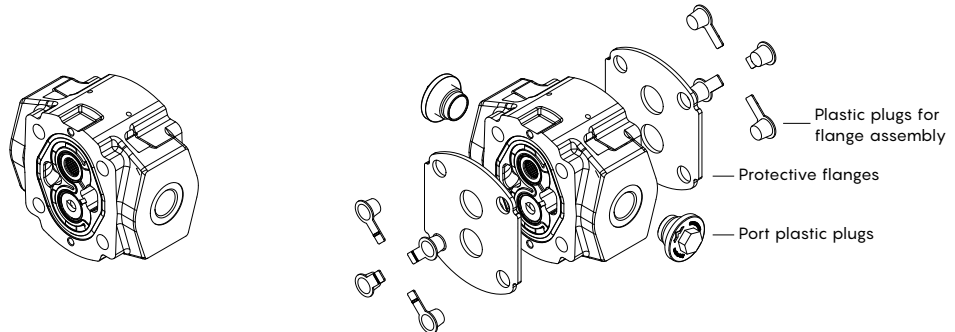

STANDARD body				
Shaft type	Displacement	Code	Description	Notes
18F tandem shaft	110	5GKBP20108	SECTION 2XPW-110-D-N-18F-0-G34G12	
	140	5GKBP20109	SECTION 2XPW-140-D-N-18F-0-G34G12	
	160	5GKBP20110	SECTION 2XPW-160-D-N-18F-0-G34G12	
	190	5GKBP20111	SECTION 2XPW-190-D-N-18F-0-G34G12	
	220	5GKBP20112	SECTION 2XPW-220-D-N-18F-0-G1G12	- Side BSP ports - NBR seals
	260	5GKBP20113	SECTION 2XPW-260-D-N-18F-0-G1G12	
	290	5GKBP20114	SECTION 2XPW-290-D-N-18F-0-G1G12	
	310	5GKBP20115	SECTION 2XPW-310-D-N-18F-0-G1G12	
18F tandem shaft	110	5GKBP20089	SECTION 2XPW-G-110-D-N-18F-0-N19N13	
	140	5GKBP20090	SECTION 2XPW-G-140-D-N-18F-0-N19N13	
	160	5GKBP20091	SECTION 2XPW-G-160-D-N-18F-0-N19N13	
	190	5GKBP20092	SECTION 2XPW-G-190-D-N-18F-0-N19N13	- Side N European flange ports - NBR seals
	220	5GKBP20093	SECTION 2XPW-G-220-D-N-18F-0-N19N13	
	260	5GKBP20094	SECTION 2XPW-G-260-D-N-18F-0-N19N13	
	290	5GKBP20095	SECTION 2XPW-G-290-D-N-18F-0-N19N13	
18F tandem shaft	110	5GKBP20082	SECTION 2XPW-110-D-N-18F-0-U12U10	
	140	5GKBP20168	SECTION 2XPW-140-D-N-18F-0-U12U10	
	160	5GKBP20169	SECTION 2XPW-160-D-N-18F-0-U12U10	
	190	5GKBP20170	SECTION 2XPW-190-D-N-18F-0-U12U10	
	220	5GKBP20171	SECTION 2XPW-220-D-N-18F-0-U16U10	- Side UN-UNF ports - NBR seals
	260	5GKBP20172	SECTION 2XPW-260-D-N-18F-0-U16U10	
	290	5GKBP20173	SECTION 2XPW-290-D-N-18F-0-U16U10	
	310	5GKBP20174	SECTION 2XPW-310-D-N-18F-0-U16U10	

# Xtreme Series

## Assembling screws ordering codes

The length of the screws indicated in the tables below refers to pumps/motors configured with aluminium and cast iron standard back cover (without aux. valves and sensors).

For different configuration contact our Sales Department.

IMPORTANT: rear covers with ports require UNI5931 screws

### For 2X single pump/motor

Displacement	For EUR – SAE – SAEB B80 – B50C flanges	For E52C flange
	Length required	Length required
040	M10x85 (3.35)	M10x80 (3.15)
060	M10x90 (3.54)	M10x85 (3.35)
080	M10x90 (3.54)	M10x90 (3.54)
110	M10x95 (3.74)	M10x95 (3.74)
140	M10x100 (3.94)	M10x100 (3.94)
160	M10x105 (4.13)	M10x105 (4.13)
190	M10x110 (4.33)	M10x110 (4.33)
220	M10x115 (4.53)	M10x115 (4.53)
260	M10x120 (4.72)	M10x120 (4.72)
290	M10x125 (4.92)	M10x125 (4.92)
310	M10x130 (5.12)	M10x125 (4.92)

### For 2X tandem pump/motor

To correctly order the assembly screws it is necessary to calculate the tandem length as shown in the picture.

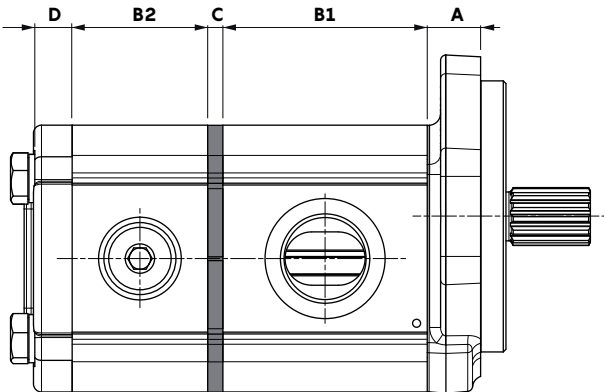

Flange			Body		
Type	A		Displacement	B	
	mm	in		mm	in
SAEA	19	0.75	040*	50.8	2
SAEB	20	0.79	060*	54.1	2.13
EUR	19	0.75	080*	58.3	2.29
B80	21	0.83	110	62.4	2.46
B50	18.8	0.74	140	67.4	2.65
E52	16.3	0.64	160	71.6	2.82
			190	76.6	3.01
			220	81.6	3.21
			260	87.4	3.44
			290	90.7	3.57
			310	95.8	3.77

(\*) displacement only for 2XP pumps/motors

Coupling kit			Cover			
Type	C		Port configuration	D		
	mm	in		mm	in	
TK	5.7	0.224	0	aluminium	14.2	0.559
TCS	28	1.10		cast iron	14	0.551
TS*	62	2.44	1/3/4	aluminium	14.2	0.559
VD	40	1.57		cast iron	16	0.630
			With aux valves	aluminium	-	-
				cast iron	16	-

(\*) this kit requires second stage fitted with EUR flange (see page 68)

## Assembling screws ordering codes

Screw type			Tie rod	
UNI 5737-10.9	UNI 5931-10.9	Length	Code	Length
107010085	101010085	M10x85 (3.35)	010243499299	M10x225 (8.86)
107010090	101010090	M10x90 (3.54)	010243499399	M10x235 (9.25)
107010090	101010090	M10x90 (3.54)	010242948999	M10x249 (9.80)
107010095	101010095	M10x95 (3.74)	010243499499	M10x255 (8.86)
107010100	101010100	M10x100 (3.94)	010242933599	M10x259 (10.20)
107010105	101010105	M10x105 (4.13)	010242916599	M10x265 (10.43)
107010110	101010110	M10x110 (4.33)	010242969999	M10x271 (10.67)
107010115	101010115	M10x115 (4.53)	010242969499	M10x279 (10.98)
107010120	101010120	M10x120 (4.72)	010242969599	M10x286 (11.26)
107010125	101010125	M10x125 (4.92)	010242969699	M10x296 (11.65)
107010130	101010130	M10x130 (5.12)	010242969799	M10x306 (12.04)
107010135		M10x135 (5.31)	010242968499	M10x313 (12.32)
107010140		M10x140 (5.51)	010243521899	M10x319 (12.56)
107010145		M10x145 (5.71)	010243045299	M10x325 (12.80)
107010150		M10x150 (5.91)	010243462199	M10x335 (13.19)
107010155		M10x155 (6.10)	010242969899	M10x343 (13.50)
107010160		M10x160 (6.30)	010243499599	M10x350 (13.78)
107010165		M10x165 (6.50)	010243104399	M10x355 (13.98)
107010170		M10x170 (6.69)	010243496399	M10x360 (14.17)
107010175		M10x175 (6.89)	010243499699	M10x365 (14.37)
107010180		M10x180 (7.09)	010243499799	M10x370 (14.57)
107010185		M10x185 (7.28)	010243047099	M10x375 (14.76)
107010190		M10x190 (7.48)	010243072799	M10x382 (15.04)
107010195		M10x195 (7.68)	Tie rods require UNI 5587 - M10 nut	
107010200		M10x200 (7.87)		
107010205		M10x205 (8.07)		
107010210		M10x210 (8.27)		
107010215		M10x215 (8.46)		
107010220		M10x220 (8.66)		
107010225		M10x225 (8.86)		
107010230		M10x230 (9.06)		
107010235		M10x235 (9.25)		
107010240		M10x240 (9.45)		
107010245		M10x245 (9.65)		
107010255		M10x255 (10.04)		
107010265		M10x265 (10.43)		
107010275		M10x275 (10.83)		
107010300		M10x300 (11.81)		

## Product identification

### 2XP aluminium pump

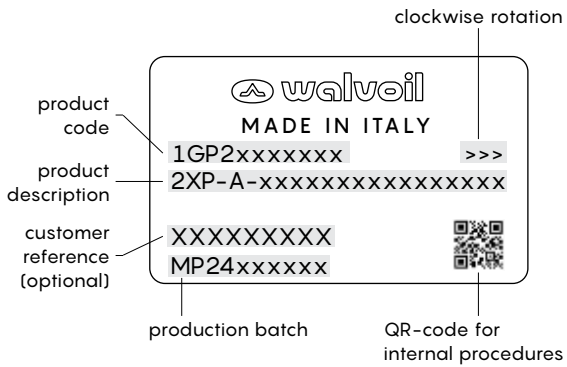

### 2XPW cast iron pump

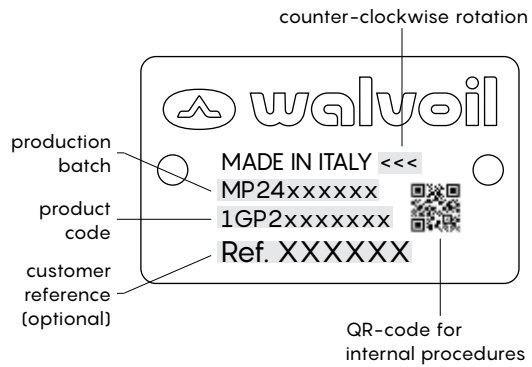



## WALVOIL NEL MONDO | WALVOIL WORLDWIDE

### WALVOIL S.P.A.

#### DIREZIONE E COORDINAMENTO INTERPUMP GROUP S.P.A.

Sede principale, Filiali e Uffici di rappresentanza  
Headquarters, Subsidiaries and Representative Offices

#### WALVOIL S.P.A. SEDE PRINCIPALE | HEADQUARTERS

Via Adige, 13/D. 42124 Reggio Emilia. Italy  
TEL. +39 0522 932411  
info@walvoil.com | www.walvoil.com

### AUSTRALASIA | AUSTRALASIA

#### WALVOIL FLUID POWER AUSTRALASIA PTY LTD

13 Vanessa Way. Delahey VIC 3037. Melbourne. Australia  
TEL. +61 458 918 750  
australasia@walvoil.com

### BRASILE | BRAZIL

#### INTERPUMP HYDRAULICS BRASIL LTDA | WALVOIL DIVISION

Rua Gilberto de Zorzi, 525. Bairro Forqueta 95115-730  
Caxias do Sul (RS)  
TEL. +55 54 3289 7000  
infobrasil@walvoil.com

### CANADA | CANADA

#### WALVOIL CANADA INC.

3100, Rue Jacob Jordan. Terrebonne. Qc J6X 4J6. Canada  
TEL. +1 450 477 1076 Ext:225  
info@walvoilcanada.com | www.walvoilcanada.com

### CINA | CHINA

#### WALVOIL FLUID POWER (DONGGUAN) CO. LTD

1st Floor, the Third Factory Area, Sijia, Shijie Town, Dongguan City  
Guangdong province, China.  
TEL. +86 769 81816189-8020  
info@walvoil.com.cn | www.walvoil.com.cn

### COREA DEL SUD | SOUTH KOREA

#### WALVOIL FLUID POWER KOREA LTD.

(17818)80-15, Oseongsandan 1Ro, Oseong-myun, Pyeongtaek-si Gyeonggi-do  
Republic of Korea 451-872  
TEL. +82 31 682 6030  
info@walvoil.co.kr | www.walvoil.co.kr

### FRANCIA | FRANCE

#### WALVOIL FLUID POWER FRANCE

362 rue de Bretagne. Vritz. 44540 Vallons-de-l'Erdre  
TEL. +33 2 41 94 41 06  
france@walvoil.com

### INDIA | INDIA

#### WALVOIL FLUID POWER (INDIA) PVT. LTD.

No. 1, 2<sup>nd</sup> Cross, 2<sup>nd</sup> Main, KIADB Industrial Area, Attibele, Anekal Taluk  
Bangalore - 562107.  
TEL. +91 80 0614 24000  
info@walvoil.co.in | www.walvoil.co.in

### MESSICO | MEXICO

#### WALVOIL FLUID POWER MEXICO S.A. DE C.V.

Julian Sepulve da Davila #109, Parque Industrial SG, cp. 66640, Apodaca  
Nuevo León, Mexico

### U.S.A. | U.S.A.

#### WALVOIL FLUID POWER CORP. | HEADQUARTERS

4111 North Garnett Tulsa, OK 74116, USA  
TEL. +1 918 858 7100  
info@walvoilusa.com | www.walvoilusa.com

#### WALVOIL FLUID POWER CORP.

1109, Technology Drive. Red Wing. MN 55066. U.S.A.  
TEL. +1 651 212 6400  
info@walvoilusa.com | www.walvoilusa.com



D2WWEM01E  
1<sup>st</sup> edition December 2024

