

FLOWFIT 12VDC SINGLE ACTING HYDRAULIC POWER PACKS

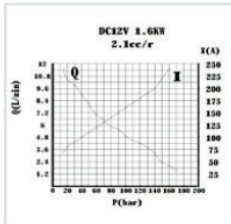

SINGLE ACTING WIRING DIAGRAM

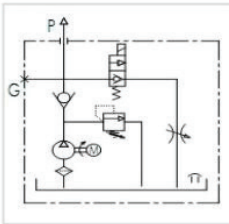
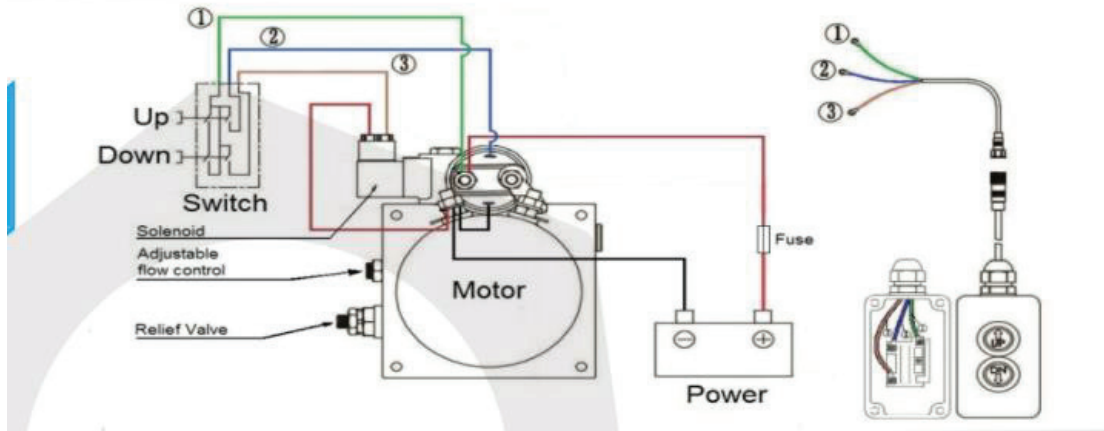

SINGLE ACTING (WITH REMOTE) WIRING DIAGRAM

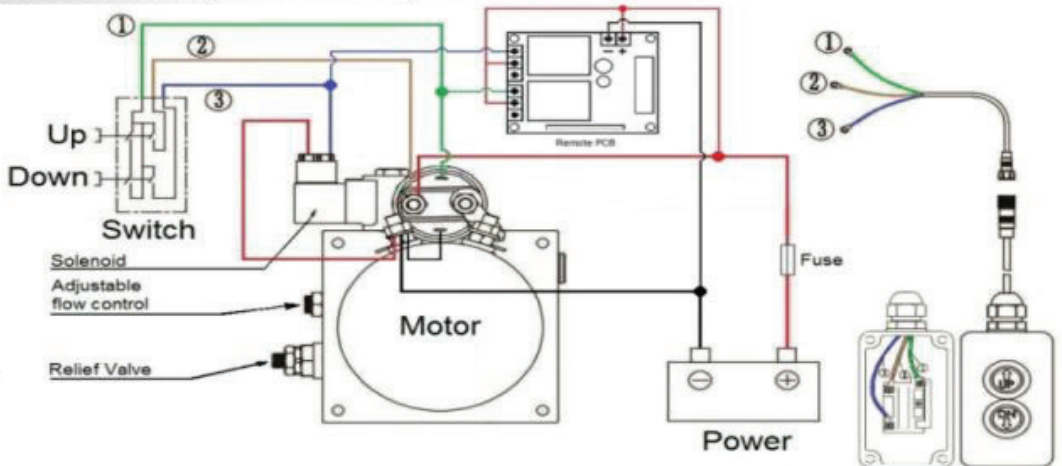

4.5 LITRE POWER PACK DIMENSIONS

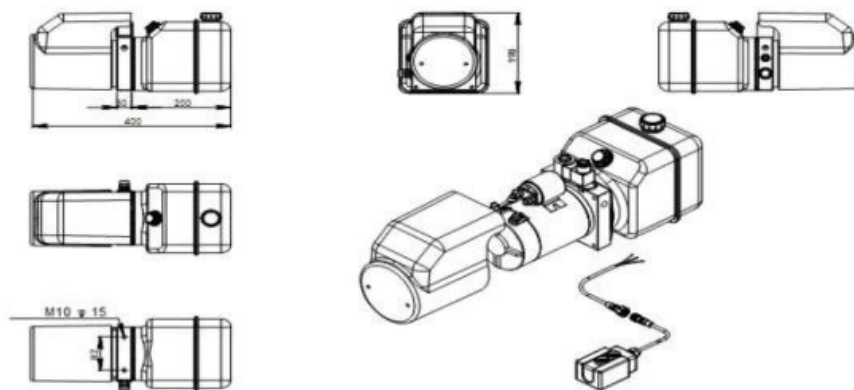

8.0 LITRE POWER PACK DIMENSIONS

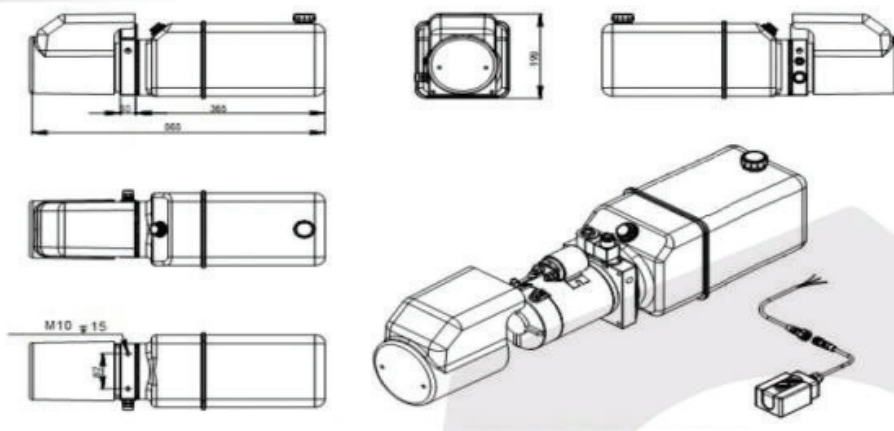

FLOWFIT® Technical Data

700 Series Standard Hydraulic Cylinders



CHARACTERISTICS

- Maximum working pressure: 200 bar
- Maximum testing pressure: 300 bar
- Maximum working speed: 0.5 m/s
- Working temperature: -30 °C to +90 °C
- Oil: mineral hydraulic

MATERIALS

- Rod: chrome plated steel F-1140, minimum chrome layer thickness 20 micron, roughness Ra < 0,2, minimum surface hardness 900 HV, corrosion resistance minimum 200 hours in neutral saline fog according to ISO9227 rating 9
- Tube: steel ST-52-3, DIN 2393, inside diameter tolerance ISO H9, roughness Ra <0,8 micron.
- Guide-bushing: steel F-1140 nitrated (nitride hardening)
- Piston: steel F-1140

SEALS

- Guide-bushing:
 - Dynamic: compact polyurethane rod-seal, double lip. NBR metal wiper seal
 - Static: NBR 90 shore o-ring
- Piston:
 - Dynamic: compact double-acting polyurethane seal, plus nitrile o-ring as activator
Special polyacetal guides reinforced with glass fibre.
 - Static: polyamide locking sealing guide

FINISHING

Black prime painting

RECOMMENDATIONS

- Protect the cylinder circuit with a relief valve set at 200 bar
- Check the oil cleanness (pollution), and prevent it from having strange objects (place a filter on the cylinder circuit)
- Bleed the circuit by slightly loosening the cylinder fittings before starting-up
- Do not weld on the cylinder tube
- Before welding on the rod or on the bottom, please dismount the cylinder. - In case you need to store the cylinders for a long period of time, please avoid outdoor storage. If not possible, the rod must be completely retracted or it must be greased instead
- For high-pressure cleaning or blasting on the cylinder, the rod and the oil-ports must be suitably protected.
- For double-acting cylinders working as single acting, we recommend to connect the non-used oil-port to tank
- In case you need to dismount the cylinder, please note that the piston is screwed onto the rod end and fixed with industrial glue, so you must use also industrial glue when mounting again

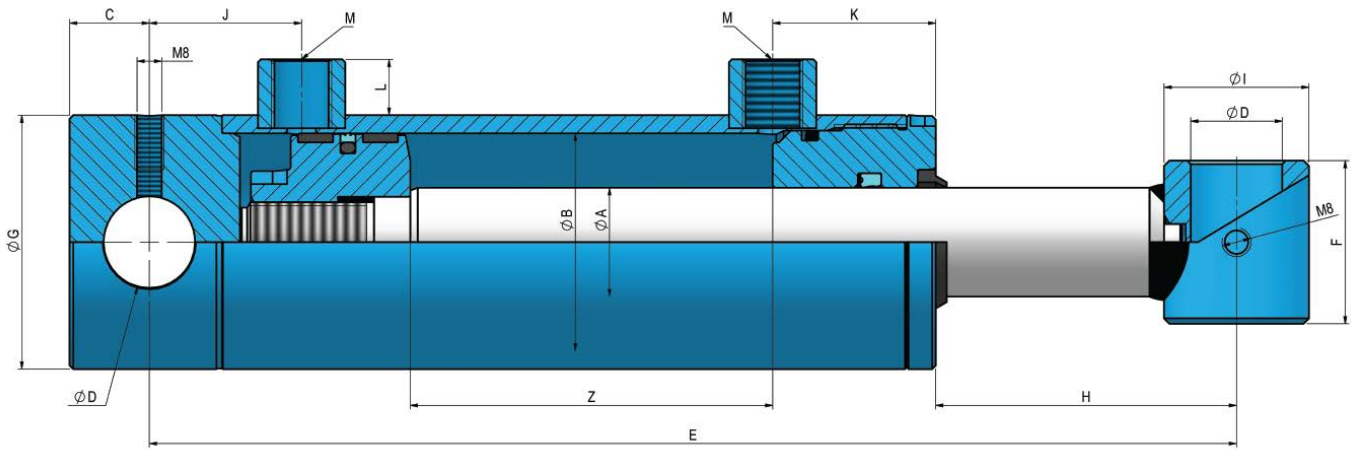

SERIES 700

REF.	ØA	ØB	STROKE z	E	C	D	F	G	H	I	J	K	L	M BSP	VOL (L)	SEALS JOINTS	WEIGHT (kg)
702/150	30	50	150	350	22	25.25	45	60	85	40	42	43	15	3/8	0.29	J72N	5.1
702/2	30	50	200	400	22	25.25	45	60	85	40	42	43	15	3/8	0.39	J72N	5.6
702/250	30	50	250	450	22	25.25	45	60	85	40	42	43	15	3/8	0.49	J72N	6.3
702/3	30	50	300	500	22	25.25	45	60	85	40	42	43	15	3/8	0.59	J72N	6.8
702/350	30	50	350	550	22	25.25	45	60	85	40	42	43	15	3/8	0.69	J72N	7.6
702/4	30	50	400	600	22	25.25	45	60	85	40	42	43	15	3/8	0.79	J72N	8.0
702/450	30	50	450	650	22	25.25	45	60	85	40	42	43	15	3/8	0.88	J72N	8.8
702/5	30	50	500	700	22	25.25	45	60	85	40	42	43	15	3/8	0.98	J72N	9.5
702/6	30	50	600	800	22	25.25	45	60	85	40	42	43	15	3/8	1.18	J72N	10.5
702/7	30	50	700	900	22	25.25	45	60	85	40	42	43	15	3/8	1.37	J72N	11.7
702/800	30	50	800	1000	22	25.25	45	60	85	40	42	43	15	3/8	1.57	J72N	13.1
702/900	30	50	900	1100	22	25.25	45	60	85	40	42	43	15	3/8	1.77	J72N	14.3
702/1000	30	50	1000	1200	22	25.25	45	60	85	40	42	43	15	3/8	1.96	J72N	15.5
702/1100	30	50	1100	1300	22	25.25	45	60	85	40	42	43	15	3/8	2.16	J72N	16.8
702/1200	30	50	1200	1400	22	25.25	45	60	85	40	42	43	15	3/8	2.35	J72N	18.0
702/1300	30	50	1300	1500	22	25.25	45	60	85	40	42	43	15	3/8	2.55	J72N	19.3
702/1400	30	50	1400	1600	22	25.25	45	60	85	40	42	43	15	3/8	2.77	J72N	20.1
702/1500	30	50	1500	1700	22	25.25	45	60	85	40	42	43	15	3/8	2.94	J72N	21.72

BUCKLING

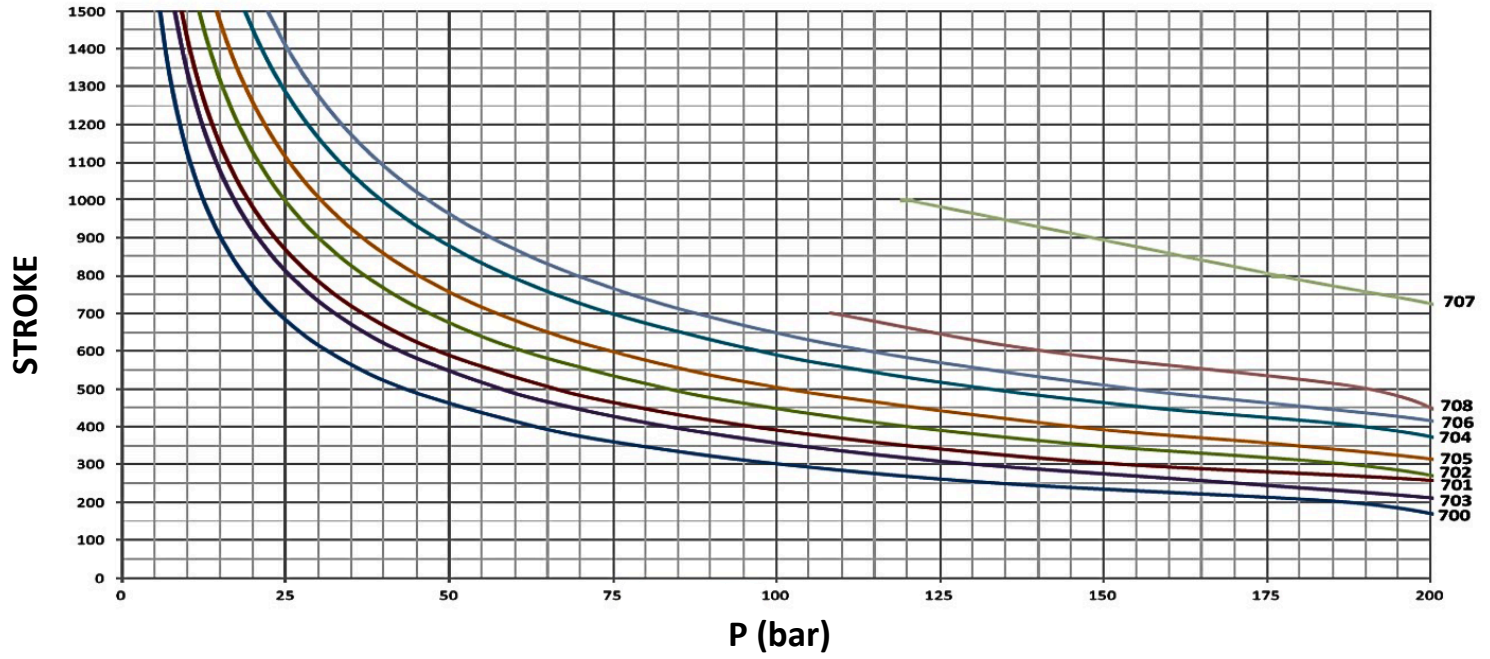

Data calculated according to euler. Safety coefficient 3.5

UPWARD THRUST

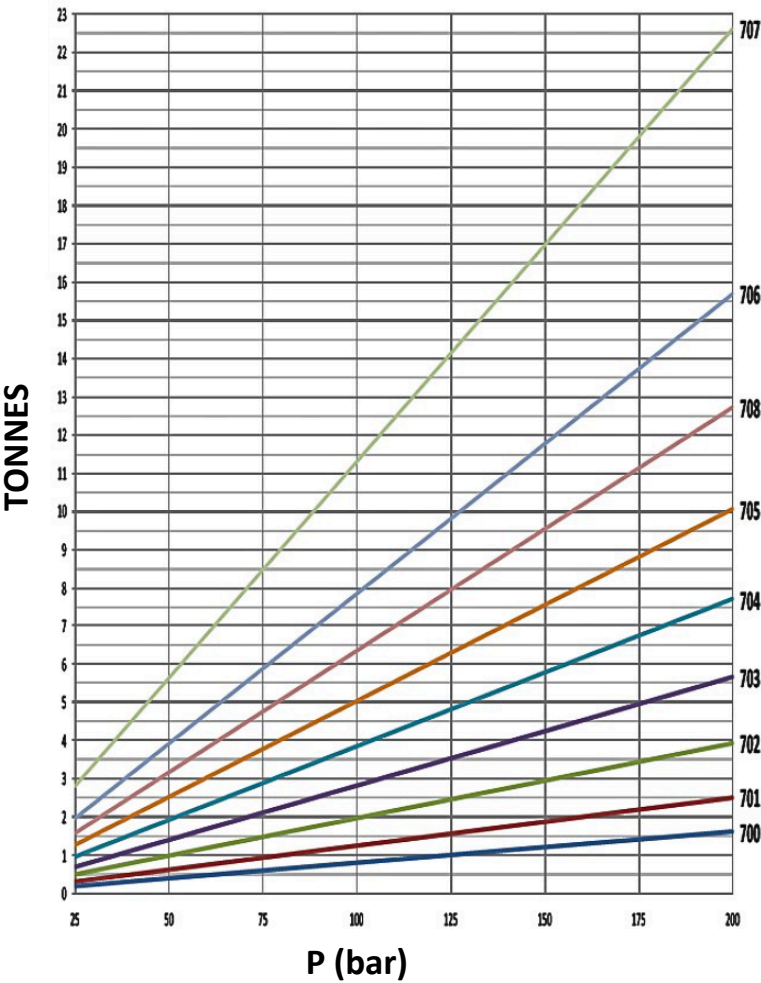

TRACTIVE EFFORT

