

### 3.2.5 Tank L100R-01

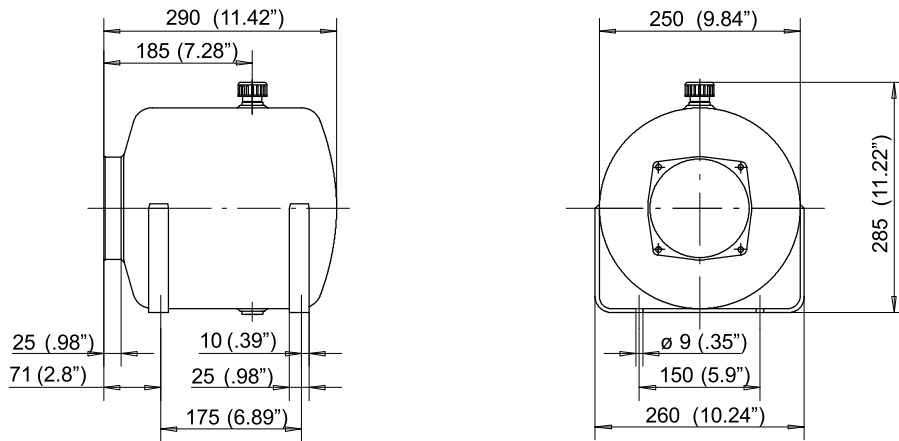

Example

	Tank						Fitting			Pos.				
3	L	1	0	0	R	-	0	1				P	0	1

Nominal Capacity	Type	Code	Oil filler cap	Oil drain plug
10 litres	L100R-01	200.9724.6002.0	1" BSP	3/4" BSP

Horizontal assembling positions

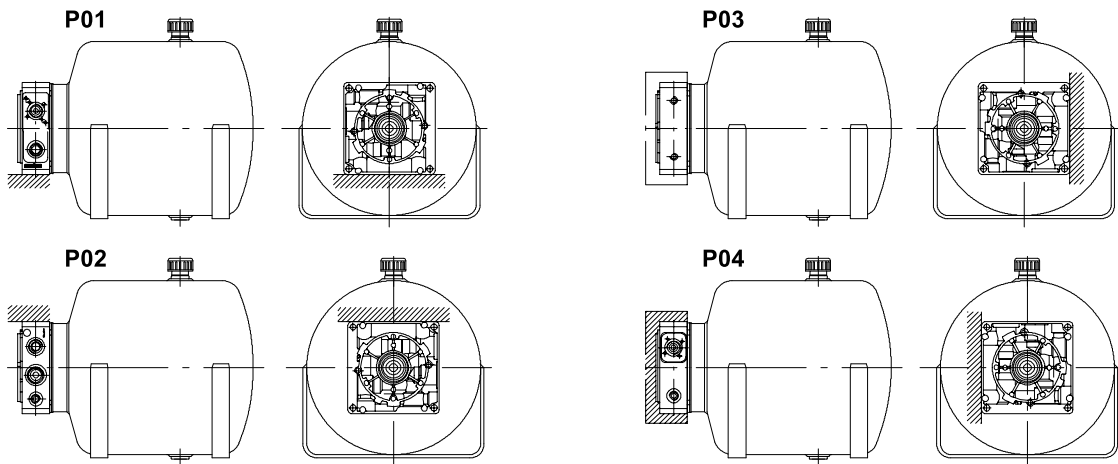

Filling capacity

AP100/5 pump, standard suction assembly kit

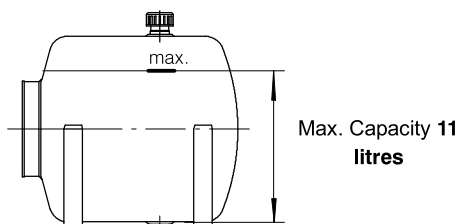

Suction capacity

AP100/5 pump, standard suction assembly kit

