

7.2.2 Pressure relief valve: **VM05

Direct acting
Balanced piston
Adjustable setting
Four setting range

Max. pressure 300 bar *
Max. flow rate 40 l/min.
Temperature range -20/+90 °C
Weight 0.200 Kg.

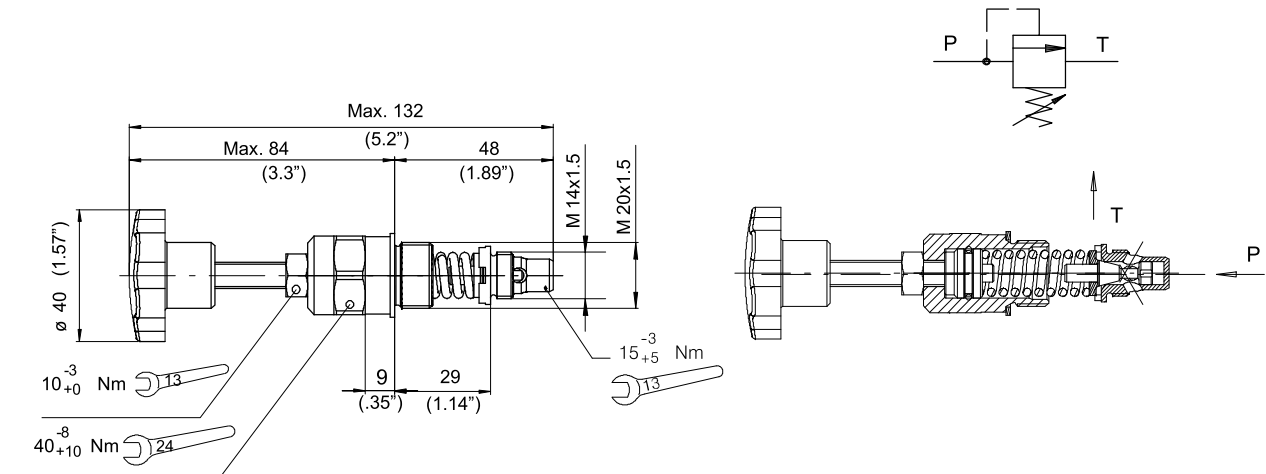

Oil: Viscosity 37 mm²/s at 40°C

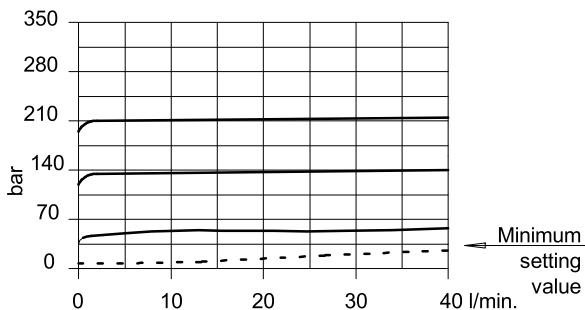

Pressure setting

For preset values other than those indicated, replace the first two digits of the designation with the setting required.

* Maximum admitted pressure value: 230 bar when used into the diecast aluminium alloy body

For example, required setting 120 bar: designation type 12VM05. Always check that the required value falls within the standard ranges of adjustment.

Note: A wrench with the appropriate hex. profile is required to secure the valve in its cavity.

Spring	Spring color	Spring code	Setting range	Standard setting	Type	Code
00			Plugged	Without valve	00VC00	200.9784.0014.0
02		200.6624.0147.0	15 - 30 bar	20 bar	02VM05	200.7874.0176.0
06	Yellow	200.6624.0145.0	30 - 95 bar	60 bar	06VM05	200.7874.0178.0
15	Green	200.6624.0148.0	95 - 210 bar	150 bar	15VM05	200.7874.0180.0
22	Blue	200.6624.0146.0	200 - 300 bar	220 bar	22VM05	200.7874.0174.0