

1.7 Anti-shock valves OA/...

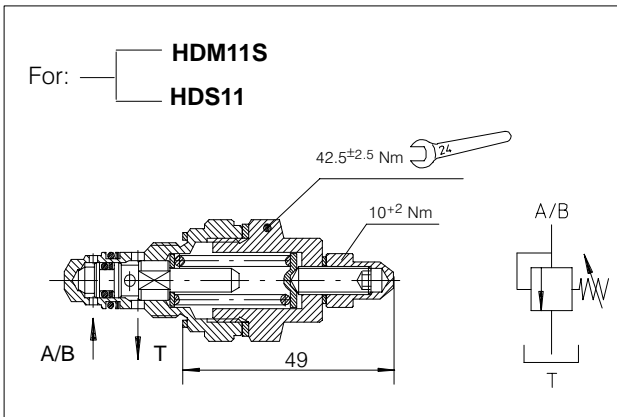

Pressure set range bar (PSI)	Type	Code	Spring code
0 - 30 (0-400)	OA/A02 OA/B02	200.7874.0092.0	200.6624.0113.0
31 - 130 (400-1900)	OA/A06 OA/B06	200.7874.0094.0	200.6624.0070.0
131 - 300 (1900-4300)	OA/A15* OA/B15	200.7874.0093.0	200.6624.0077.0
VC (plugged valve)		200.7784.0004.0	-

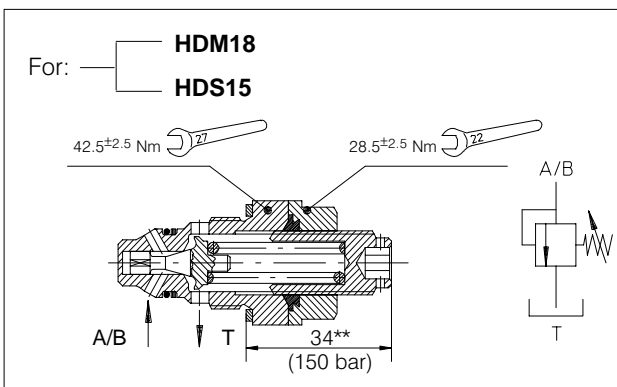

Pressure set range bar (PSI)	Type	Code	Spring code
0 - 130 (0-1900)	OA/A06 OA/B06	200.7874.0095.0	200.6624.0115.0
131 - 350 (1900-5000)	OA/A15 OA/B15	200.7874.0096.0	200.6624.0116.0
VC (plugged valve)		200.7784.0005.0	-

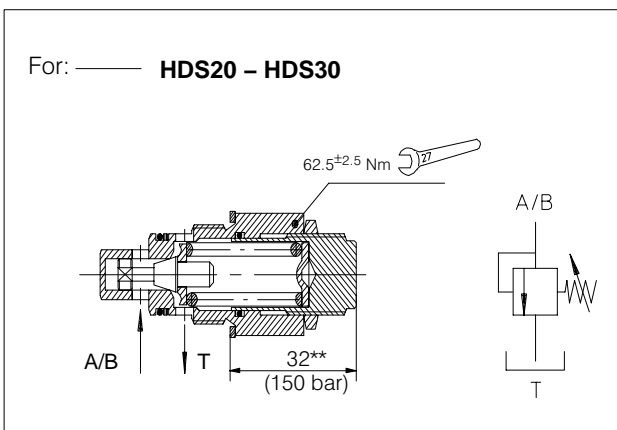

Pressure set range bar (PSI)	Type	Code	Spring code
0 - 95 (0-1300)	OA/A06 OA/B06	200.7874.0108.0	200.6624.0145.0
96 - 210 (1300-3000)	OA/A15 OA/B15	200.7874.0113.0	200.6624.0148.0
211 - 350 (3000-5000)	OA/A26 OA/B26	200.7874.0110.0	200.6624.0146.0
VC (plugged valve)		200.7784.0007.0	-

Example : OA/A15** = 150 bar standard set value. Different set values have to be specified at the order. Please pay attention that any increasing/decreasing from 150 bar has to be fixed in step of 10 bar.

** : This length changes as function of the pressure relief valve setting