

### 7.8.2 Flow control valve: VRC818/\*-R

Compensated  
Adjustable setting  
Two setting flow ranges  
Flow from 2 to 1

Max. pressure ..... 250 bar  
Max. flow ..... 50 l/min.  
Controlled ..... 1-6 l/min.  
..... 5-30 l/min.  
Temperature range ..... -20/+90 °C  
O-Ring replacement kit ..... 200.9742.0015.0  
Weight ..... 0.260 Kg.

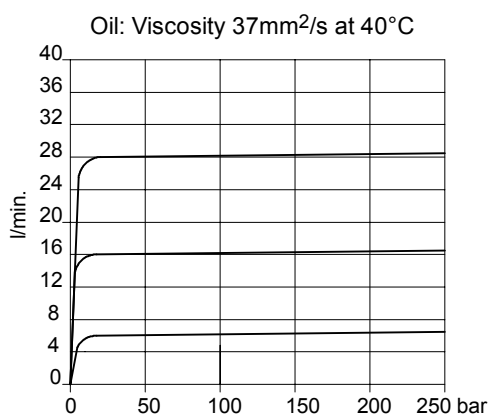
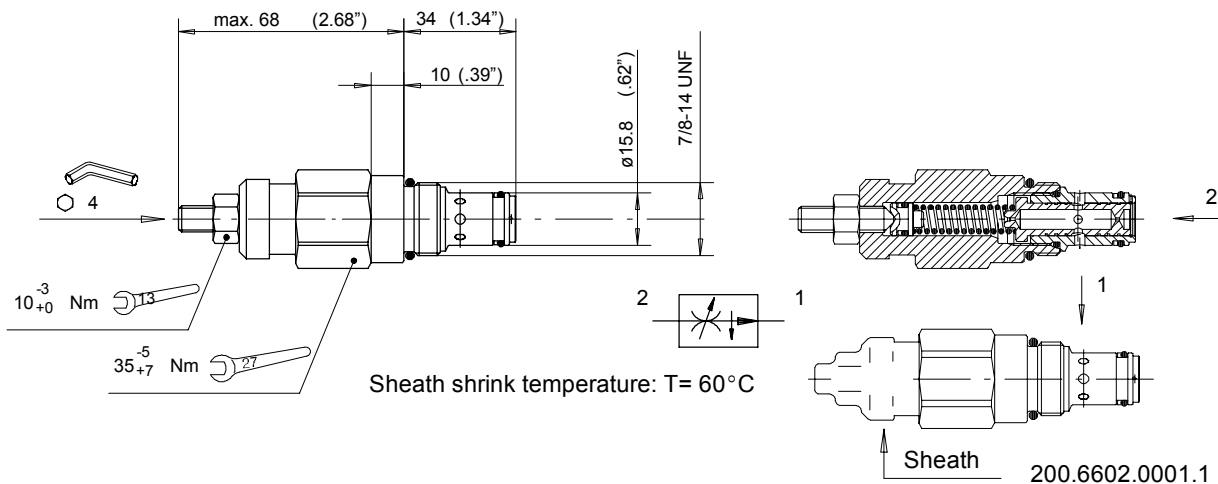

A heat-shrinkable sheath can be supplied, if requested to prevent the valve being tampered with.

When ordering, state in full the sheath part number, and, if the valve is to be supplied with sheath already fitted, the flow value setting required.

Setting range	Type	Code
1-6 l/min.	<b>VRC818/A-R</b>	200.7872.0083.0
5-30 l/min.	<b>VRC818/B-R</b>	200.7872.0084.0

Fixed version

**VRC818/\*-F\*\***

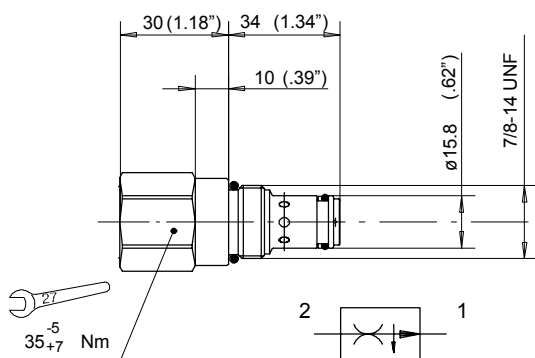

Nominal flow (l/min) ±12%	Type	Code
10	<b>VRC818/D-F10</b>	200.7872.0149.0
12	<b>VRC818/C-F12</b>	200.7872.0085.0
20	<b>VRC818/B-F20</b>	200.7872.0097.0
30	<b>VRC818/B-F30</b>	200.7872.0103.0