

## 7.11 Valve cavity plugs

### 7.11.1 Valve cavity plug T817/0

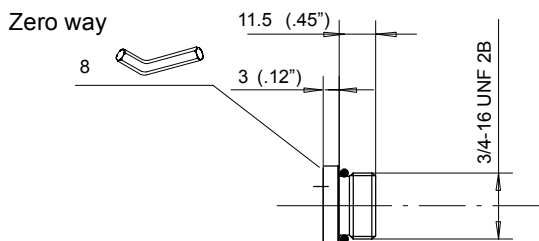

Code	<b>200.5274.81701</b>
O-Ring code	200.5142.24711
Weight	0.040 Kg.

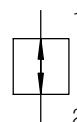

### 7.11.2 Valve cavity plug T817/2

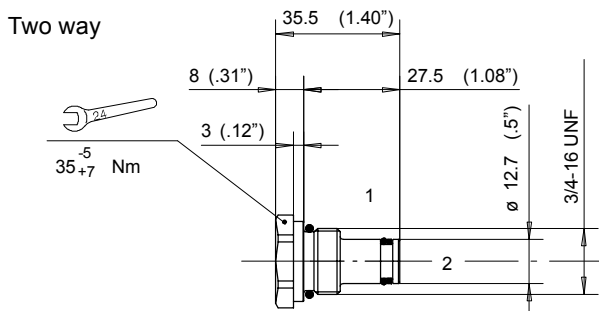

Code	<b>200.7788.0002.0</b>
Seal kit code	200.9742.0016.0
Weight	0.070 Kg.

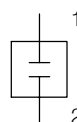

### 7.11.3 Valve cavity plug T818/0

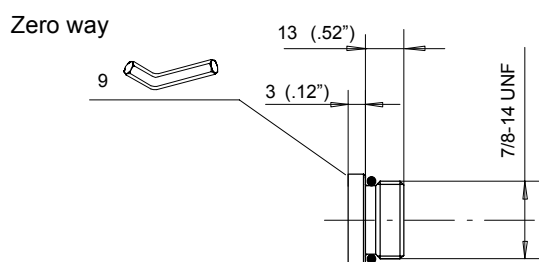

Code	<b>200.5274.81801</b>
O-Ring code	200.5142.31511
Weight	0.080 Kg.

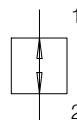

### 7.11.4 Valve cavity plug T817/2P-602

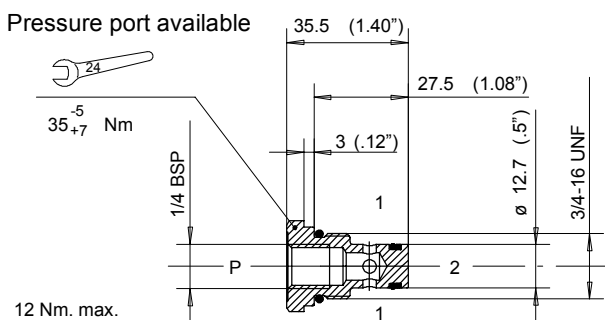

Code	<b>200.7788.0006.0</b>
Seal kit code	200.9742.0016.0
Weight	0.040 Kg.

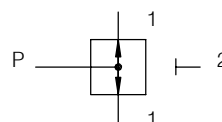

### 7.11.5 Valve cavity plug T817/2T-602

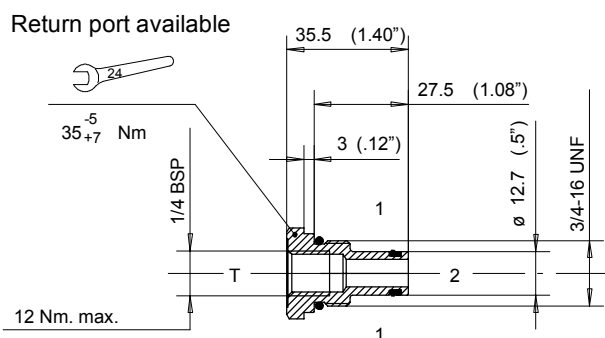

Code	<b>200.7788.0007.0</b>
Seal kit code	200.9742.0016.0
Weight	0.030 Kg.

