

ELECTROCLUTCHES

FLOWFIT ELECTRO CLUTCHES KRS30 SERIES GROUP 2 & 3 - 100NM

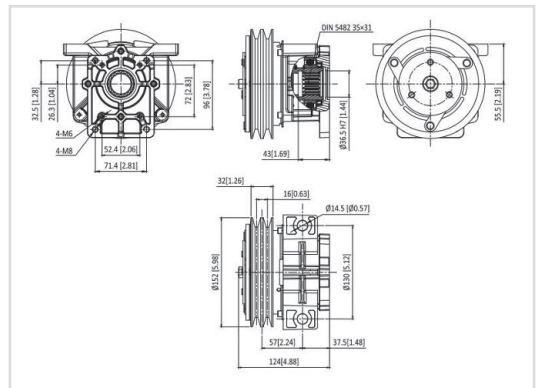

PART NO.	DESCRIPTION OF CLUTCH	GEAR PUMP FLANGE
KRS30901	Flowfit Electromagnetic Reversible Clutch 12V - 100Nm	Group 1 & 2
KRS30903	Flowfit Electromagnetic Reversible Clutch 24V - 100Nm	Group 1 & 2

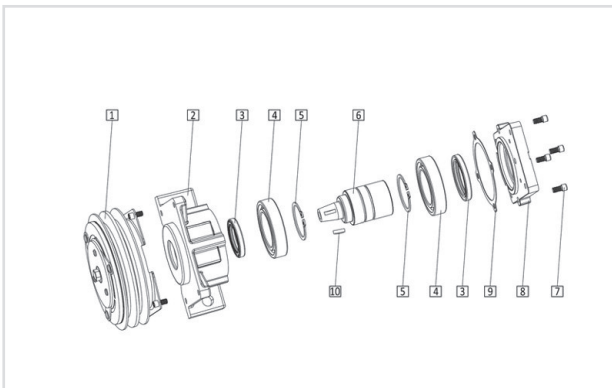

NO.	DESCRIPTION	QUANTITY	NO.	DESCRIPTION	QUANTITY
1	Electric clutch	1	6	Shaft	1
2	Housing	1	7	Gasket	1
3	Sealing ring	2	8	Flange for pump	1
4	Bearing	2	9	Socket cap screw	4
5	Snap ring	2	10	Woodruff key	1

Nominal torque	78Nm	
Static torque	125Nm	
Dynamic torque	85Nm	At 500 rpm
	70Nm	At 1000 rpm
	42Nm	At 1500 rpm
	35Nm	At 2000 rpm
	27Nm	At 2500 rpm
	25Nm	At 3000 rpm

Connection time	25 m/sec
Disconnection time	40 m/sec
Minimum time between two connection	20 sec
Max. speed	5000 rpm
Weight	5.0 Kg

Type	Electric absorption	Resistance(Ω)		Current(A)		Power(W)	
		20°C	120°C	20°C	120°C	20°C	120°C
KRS30901	12 V DC	4	5.6	3.33	2	40	24
KRS30903	24 V DC	20	28	1.26	0.77	30.3	18.18

All technical data at 20°C/at 120°C the performance are less 20%, all electromagnetic clutches are reversible.