

REDUCTION GEARBOXES

FLOWFIT REDUCTION GEARBOXES KR600 SERIES GROUP 2 PUMP - 10KW

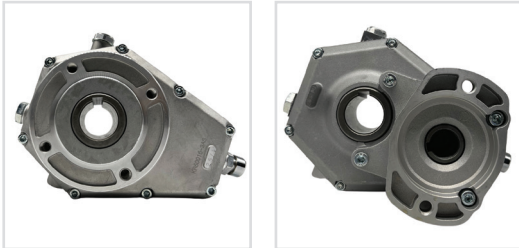

KR60016-3AS

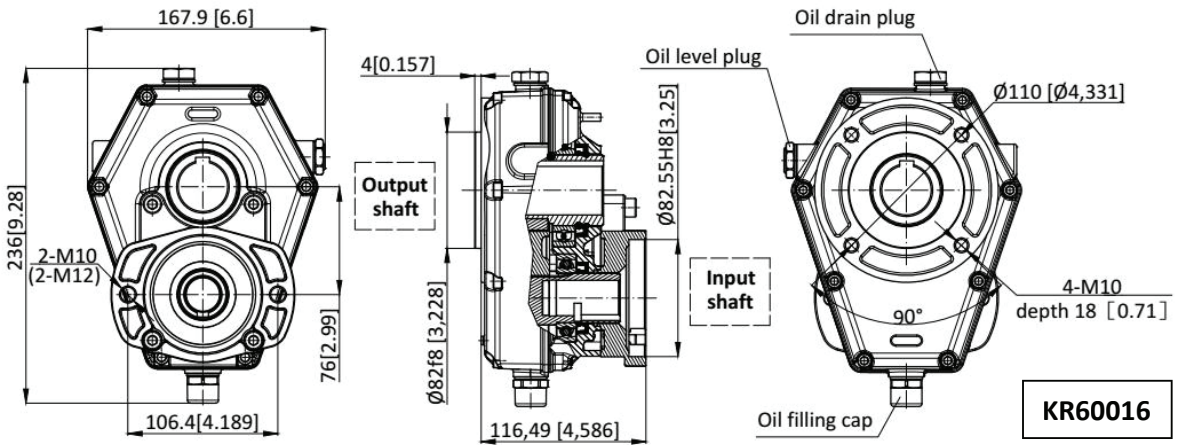

KR60016

M1 MAXIMUM CONTINUOUS TORQUE OF THE SPEED INCREASER (INPUT SIDE daNm)	M2 MAXIMUM TORQUE OF THE SPEED INCREASER (OUTPUT SIDE daNm)	N1 OUTPUT SPEED AFTER REDUCTION RPM	N2 INPUT SPEED BEFORE REDUCTION RPM	I RATO OF SPEED REDUCTION ON N2 = N1	MAX TRANSMITTABLE POWER KW	WEIGHT KG
19,6	13,1	200	300	1,5	10	5
17,6	8,8	200	400	2	10	5
19,2	7,7	200	500	2,5	10	5
20,1	6,7	200	600	3	10	5
21,4	6,3	200	700	3,5	10	5
18,6	4,9	200	760	3,8	10	5

How to order:

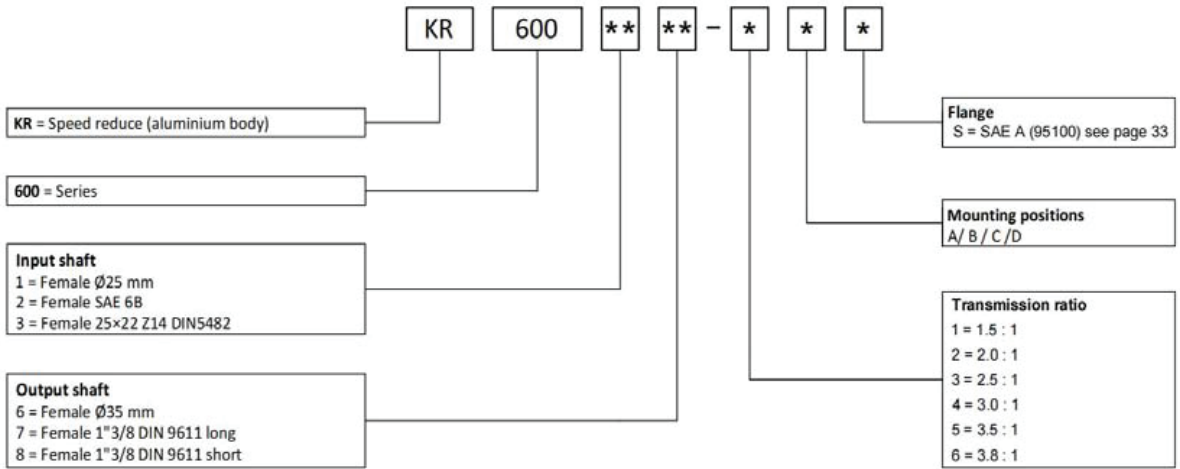

For example: KR60016-1AS

PART NO.	DESCRIPTION OF REDUCTION GEARBOX	MOUNT	RATIO	OUTPUT SHAFT
KR60016-2AS	GRP2 REDUCTION GEARBOX 10KW	SAE A MOUNT 25MM	1:2	Female Ø35 mm
KR60016-3AS	GRP2 REDUCTION GEARBOX 10KW	SAE A MOUNT 25MM	1:2,5	Female Ø35 mm
KR60016-4AS	GRP2 REDUCTION GEARBOX 10KW	SAE A MOUNT 25MM	1:3	Female Ø35 mm
KR60016-5AS	GRP2 REDUCTION GEARBOX 10KW	SAE A MOUNT 25MM	1:3,5	Female Ø35 mm
KR60016-6AS	GRP2 REDUCTION GEARBOX 10KW	SAE A MOUNT 25MM	1:3,8	Female Ø35 mm