

NO ENGINE AUTO KICK OUT LEVER VALVE LOG SPLITTER STARTER KITS

Flowfit's No-Cylinder Log Splitter Kits are perfect for users who already have a hydraulic cylinder or prefer to source their own. These kits come with all the essential components required for a reliable and efficient log-splitting setup, excluding the cylinder itself.

Available in three distinct variants: Compact, Evolution, and Classic.



TYPE	INLET/OUTLET PORTS	WORKING PORTS	MAX FLOW (LPM)	MAX PRESSURE (PSI)	RELIEF VALVE	KICK OFF PRESSURE	WEIGHT
COMPACT (ZZ005421)	3/4" BSP	1/2" BSP	81	3265 (225 BAR)	Adjustable, preset at 2,750 PSI (189 BAR)	Non-adjustable, preset at 800 PSI (55 BAR)	2.2Kg
EVOLUTION (LS305NBA42)	3/4" BSP	1/2" BSP	136	3625 (230 BAR)	Adjustable, preset at 2,250 PSI (155 BAR)	Non-adjustable, preset at 800 PSI (55 BAR)	4.5Kg
CLASSIC (LS255BBA43)	3/4" BSP	1/2" BSP	113	2750 (189 BAR)	Adjustable, preset at 2,250 PSI (155 BAR)	Adjustable from 1000-2600 PSI (179 BAR), preset at 1400 PSI (96 BAR)	4.5Kg

AUTO KICK OUT VALVE

- Constructed of high tensile strength gray cast iron
- Built-in adjustable relief valve
- Hard chrome plated spool

RECOMMENDED HYDRAULIC SYSTEM

- Maximum tank pressure: 500 PSI (35 BAR)
- Maximum operating temperature: 180°F
- Recommended system filtration: 10 micron

STANDARD FEATURES

- Maximum LPM: 81
- Maximum operating pressure : 3,000 PSI (207 BAR)
- Spool action is spring centre/hydraulic kick-off
- Built-in relief valve preset at 1,800 PSI (124 BAR)
- Kick-off pressure is non-adjustable, preset at 800 PSI (55 BAR)
- Handle can be installed in "up" or "down" position

COMPACT

Pressure Drop

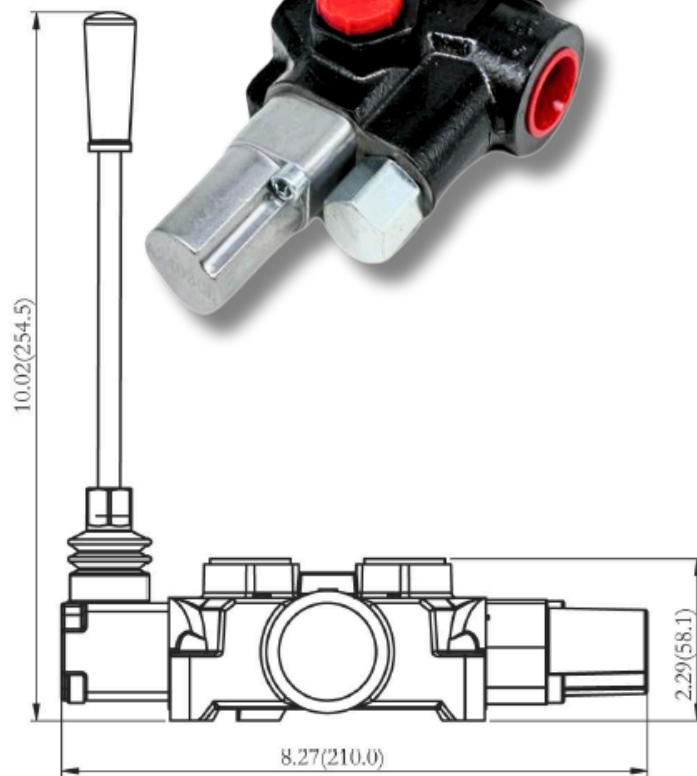
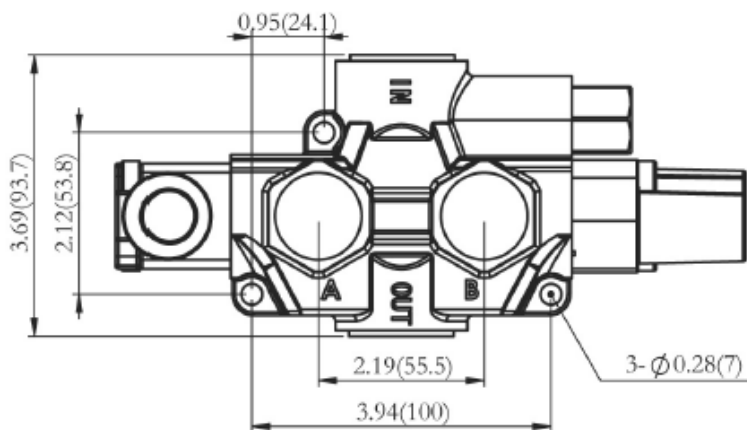
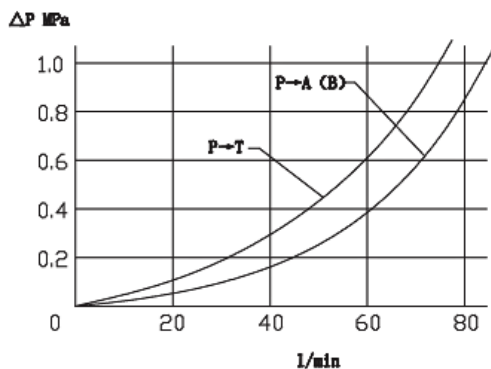

PART NUMBER	INLET/OUTLET PORTS	WORKING PORTS	MAX FLOW (LPM)	MAX PRESSURE (PSI)	RELIEF VALVE	KICK OFF PRESSURE	WEIGHT
ZZ005421	3/4" BSP	1/2" BSP	81	3265 (225 BAR)	Adjustable, preset at 2,750 PSI (189 BAR)	Non-adjustable, preset at 800 PSI (55 BAR)	2.2Kg

AUTO KICK OUT VALVE

- Constructed of high tensile strength gray cast iron
- Built-in adjustable relief valve
- Hard chrome plated spool

RECOMMENDED HYDRAULIC SYSTEM

- Maximum tank pressure: 500 PSI (35 BAR)
- Maximum operating temperature: 180°F
- Recommended system filtration: 10 micron

STANDARD FEATURES

- Maximum LPM: 136
- Maximum operating pressure : 3,500 PSI (241 BAR)
- Spool action is spring centre/hydraulic kick-off
- Built-in relief valve preset at 1,800 PSI (124 BAR)
- Kick-off pressure is non-adjustable, preset at 800 PSI (55 BAR)
- Handle can be installed in "up" or "down" position

EVOLUTION



Pressure Drop

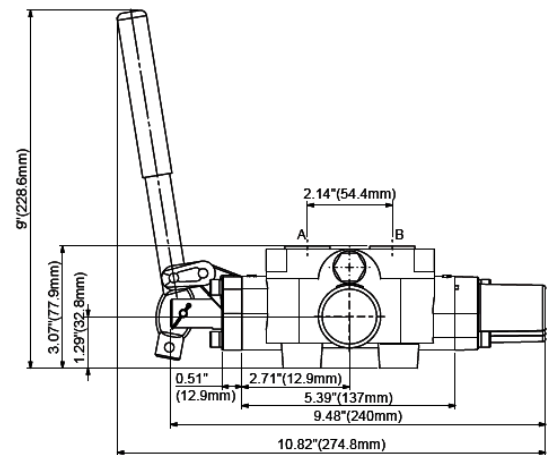
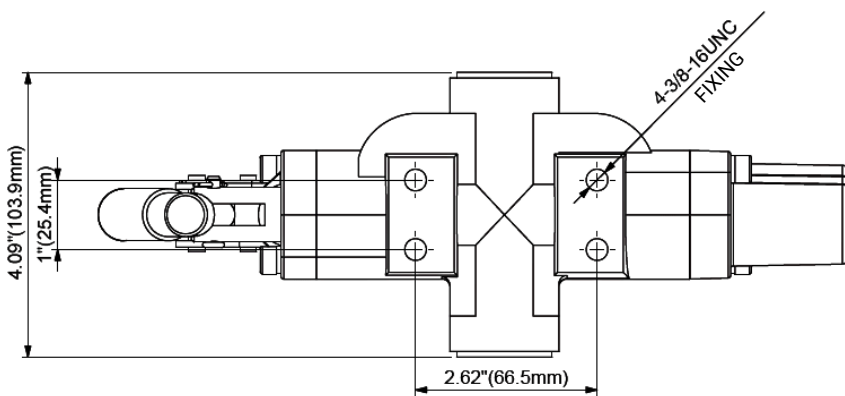
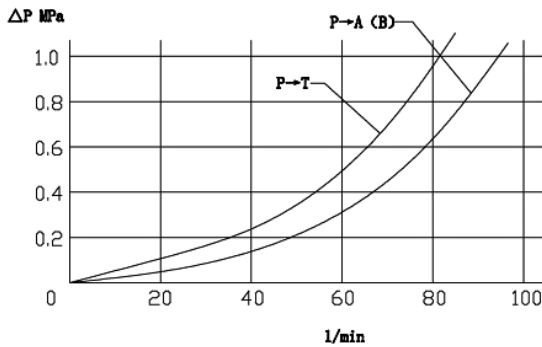

PART NUMBER	INLET/OUTLET PORTS	WORKING PORTS	MAX FLOW (LPM)	MAX PRESSURE (PSI)	RELIEF VALVE	KICK OFF PRESSURE	WEIGHT
LS305NBA42	3/4" BSP	1/2" BSP	136	3625 (230 BAR)	Adjustable, preset at 2,250 PSI (155 BAR)	Non-adjustable, preset at 800 PSI (55 BAR)	4.5Kg

AUTO KICK OUT VALVE

- Constructed of high tensile strength gray cast iron
- Built-in adjustable relief valve
- Hard chrome plated spool

RECOMMENDED HYDRAULIC SYSTEM

- Maximum tank pressure: 500 PSI (35 BAR)
- Maximum operating temperature: 180°F
- Recommended system filtration: 10 micron

STANDARD FEATURES

- Maximum LPM: 113
- Maximum operating pressure : 3,500 PSI (241 BAR)
- Built-in relief valve preset at 2,250 PSI (155 BAR)
- Kick-off pressure adjustable from 1000-2600 psi (179 BAR), at 1400 psi (96 BAR)
- Automatically kicks back to neutral when cylinder completes stroke
- Handle can be installed in "up" or "down" position

Pressure Drop

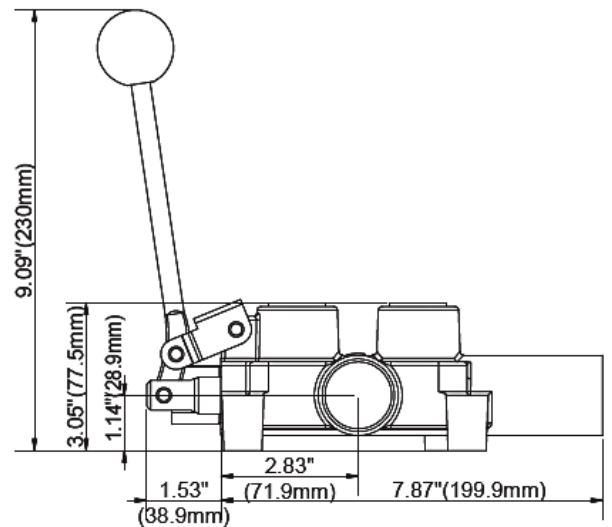
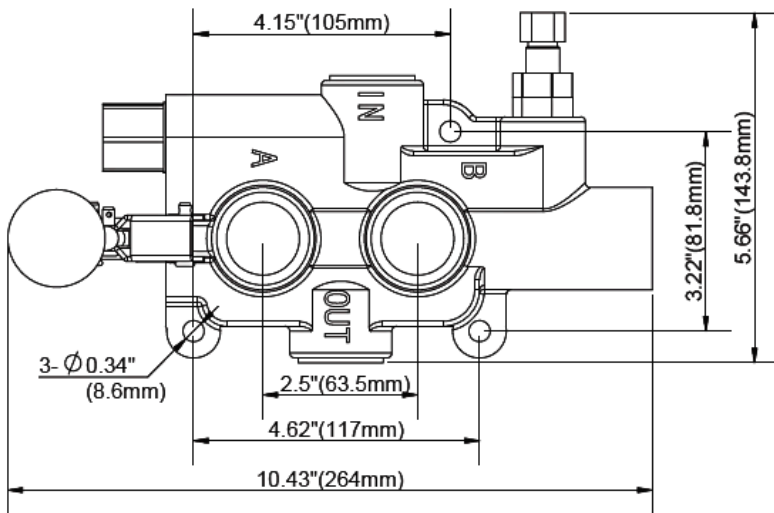
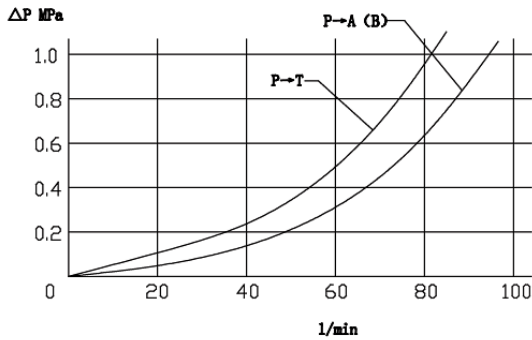

CLASSIC



PART NUMBER	INLET/OUTLET PORTS	WORKING PORTS	MAX FLOW (LPM)	MAX PRESSURE (PSI)	RELIEF VALVE	KICK OFF PRESSURE	WEIGHT
LS255BBA43	3/4" BSP	1/2" BSP	113	2750 (189 BAR)	Adjustable, preset at 2,250 PSI (155 BAR)	Adjustable from 1000-2600 PSI (179 BAR), preset at 1400 PSI (96 BAR)	4.5Kg

DOUBLE ACTING CYLINDER

SPECIALISED



ADVANTAGES

- REAR BASE PORT FOR EASE OF ACCESS
- REDUCED ROD DIAMETER FOR AXE ENGAGEMENT
- PRE FITTED WITH 4 BOLT MOUNTING FLANGE
- OVERSIZED ROD FOR DURABILITY & FAST RETRACTION
- 3265 MAX PRESSURE / NON-ADJUST KICK OUT

**PAINTED
VERSION
AVAILABLE**

TONNAGE @ 200BAR + 3000RPM	CYLINDER BORE (MM)	STROKE (MM)
7.7	70	550
10	80	650
12.7	90	650



The kit includes an Italian gear pump and a bellhousing engine set, designed to meet all your log-splitting needs.

PLEASE NOTE THIS KIT DOES NOT INCLUDE AN ENGINE